

BOARD OF DIRECTORS MEETING
THURSDAY, OCTOBER 18, 2012

A-G-E-N-D-A

Call to Order - 4 pm	Dr. Stocker
1. Adoption of Minutes: September 27, 2012	
<u>Chairman's Report</u>	Dr. Stocker
<u>President's Report</u>	Mr. Aviles
>>Action Items<<	
<u>Corporate</u>	
2. RESOLUTION authorizing the President of the New York City Health and Hospitals Corporation to negotiate and execute a renewal and amendment to the contract with SunGard Availability Services for an alternate data center for disaster recovery, business continuity and associated professional services . Funding for the four-year renewal term per the Corporation's exercise of its renewal options under the existing contract shall not exceed \$25,550,000 (which includes 20% contingency of \$4,262,480). <i>(Med & Professional Affairs/Information Technology Committee – 10/11/2012)</i> EEO: Conditional / VENDEX: Pending	Dr. Stocker
3. RESOLUTION authorizing the President of the New York City Health and Hospitals Corporation to execute the third of three one-year renewal options available under the existing contract with Simpler North America, LP . Funding for the exercise of the third of three one-year renewal options available under the existing contract shall not exceed 5,500,000 inclusive of a 10% contingency for the period from November 1, 2012 through October 31, 2013. <i>(Strategic Planning Committee – 10/16/2012)</i> EEO: Approved / VENDEX: Pending	Mrs. Bolus
4. RESOLUTION authorizing the President of the New York City Health and Hospitals Corporation to execute a requirements contract with Nirman Construction, Inc. for a cumulative amount not-to-exceed \$5,000,000 to provide construction services for General Construction Work on an as-needed basis at various facilities throughout the Corporation. <i>(Capital Committee – 10/11/2012)</i> EEO: / VENDEX: Approved	Ms. Youssef
5. RESOLUTION authorizing the President of the New York City Health and Hospitals Corporation to execute a lease agreement with 160 Water Street Associates for the Corporation's rental of space at 160 Water Street, Borough of Manhattan, to house Corporation staff . <i>(Capital Committee – 10/11/2012)</i>	Ms. Youssef
6. RESOLUTION authorizing the President of the New York City Health and Hospitals Corporation to execute a lease agreement with New Water Street Corporation , for the Corporation's rental of space at 55 Water Street, Borough of Manhattan, to house Corporation staff . <i>(Capital Committee – 10/11/2012)</i>	Ms. Youssef
7. RESOLUTION authorizing the amendment of the resolutions adopted by the Board of Directors of the New York City Health and Hospitals Corporation (the "Corporation") on September 27, 2012 that authorized the creation of the HHC Finance Corporation, the participation of the Corporation in a certain set of transactions to secure supplemental financing for the Harlem Hospital Modernization project and to authorize the directors of the HHC Finance Corporation to also authorize the participation of the HHC Finance Corporation in such transactions (the "resolutions") so as to replace in the Resolutions all references made to the HHC Finance Corporation with references to the HHC Assistance Corporation and ratifying the actions taken to form the HHC Assistance Corporation .	Mr. Aviles
<i>(over)</i>	

**BOARD OF DIRECTORS MEETING
THURSDAY, OCTOBER 18, 2012 ~ AGENDA ~ Page Two**

<p><u>Various Networks</u></p> <p>8. RESOLUTION authorizing the President of the New York City Health and Hospitals Corporation to execute one year revocable license agreements with the New York City Human Resources Administration for use and occupancy of space for primary care programs located at 1420 Bushwick Avenue, Borough of Brooklyn, 413 E. 120th Street, Borough of Manhattan and 114-02 Guy Brewer Boulevard, Borough of Queens administered by Woodhull Medical and Mental Health Center, Metropolitan Hospital Center and Queens Hospital Center. (Capital Committee – 10/11/2012)</p>	<p>Ms. Youssouf</p>
<p><u>Committee Reports</u></p> <ul style="list-style-type: none"> ➤ Audit ➤ Capital ➤ Equal Employment Opportunity ➤ Finance ➤ Medical & Professional Affairs / Information Technology ➤ Strategic Planning 	<p>Ms. Youssouf Ms. Youssouf Rev. Lacey Mr. Rosen Dr. Stocker Mrs. Bolus</p>
<p><u>Subsidiary Board Report</u></p> <ul style="list-style-type: none"> ➤ MetroPlus Health Plan, Inc. 	<p>Mr. Rosen</p>
<p><u>Facility Governing Body / Executive Session</u></p> <ul style="list-style-type: none"> ➤ Harlem Hospital Center <p>>>Old Business<< >>New Business<<</p>	
<p>Adjournment</p>	<p>Dr. Stocker</p>

NEW YORK CITY HEALTH AND HOSPITALS CORPORATION

A meeting of the Board of Directors of the New York City Health and Hospitals Corporation (hereinafter the "Corporation") was held in Room 532 at 125 Worth Street, New York, New York 10013 on the 27th of September 2012 at 4:00 P.M. New York time, pursuant to a notice which was sent to all of the Directors of the Corporation and which was provided to the public by the Secretary. The following Directors were present in person:

Dr. Michael A. Stocker
Rev. Diane E. Lacey
Mr. Alan D. Aviles
Josephine Bolus, R.N.
Dr. Jo Ivey Boufford
Dr. Vincent Calamia
Mr. Robert Doar
Dr. Christina L. Jenkins
Dr. Adam Karpati
Ms. Anna Kril
Mr. Robert F. Nolan
Mr. Bernard Rosen

Andrea Cohen was in attendance representing Deputy Mayor Linda Gibbs; Linda Hacker representing Mr. Robert Doar (before his departure); and Dr. Amanda Parsons representing Commissioner Thomas Farley, each in a voting capacity. Dr. Stocker chaired the meeting and Mr. Salvatore J. Russo, Secretary to the Board, kept the minutes thereof.

ADOPTION OF MINUTES

The minutes of the meeting of the Board of Directors held on July 26, 2012 were presented to the Board. Then, on motion made by Dr. Stocker and duly seconded, the Board unanimously adopted the minutes.

1. **RESOLVED**, that the minutes of the meeting of the Board of Directors

held on July 26,2012, copies of which have been presented to this meeting, be and hereby are adopted.

CHAIRPERSON'S REPORT

Dr. Stocker received the Board's approval to convene an Executive Session to discuss matters of personnel.

Dr. Stocker updated the Board on approved and pending Vendex and will report on the status of pending Vendex at the next Board meeting.

Dr. Stocker announced the dates of HHC's annual public meetings as follows: November 7th at Coney Island Hospital; November 19th at Jacobi Medical Center; December 3rd at Queens Hospital Center; December 5th at Sea View Hospital and Rehabilitation Center and Home; and December 12th at Bellevue Hospital Center.

PRESIDENT'S REPORT

Mr. Aviles' remarks were in the Board package and made available on HHC's internet site. A copy is attached hereto and incorporated by reference.

ACTION ITEMS

RESOLUTION

2. Authorizing the President of the New York City Health and Hospitals Corporation to negotiate and execute a contract with Epic Systems Corporation for an enterprise-wide Electronic Medical Record (EMR) System including the software license, installation, training and maintenance to be used throughout the Corporation's facilities. The contract will be for an initial term of ten years with an additional five-year renewal option, exercisable solely by the Corporation, in an amount not to exceed \$302,807,986.

Dr. Louis Capponi, HHC's Chief Medical Informatics Officer, discussed the importance of upgrading HHC's electronic medical records system. He emphasized that Epic is a strong company used by the largest integrated delivery systems in the country and will be able to fulfill the future goals of the Corporation. Joel Forman, an attorney representing Allscripts Healthcare Solutions, Inc., spoke against the selection of Epic.

Dr. Stocker then moved the adoption of the resolution with following amendment which was duly seconded and unanimously adopted by the Board: "the Board's approval is contingent upon the final determination by the Procurement Review Board, which will be shared with the Board members."

RESOLUTIONS

6. Authorizing the President of the New York City Health and Hospitals Corporation to execute a requirements contract with Rashel Construction Corporation for a cumulative amount not-to-exceed \$5,000,000 to provide construction services for General Construction work on an as-needed basis at various facilities throughout the Corporation.

- AND -

7. Authorizing the President of the New York City Health and Hospitals Corporation to execute a requirements contract with Volmar Construction, Inc. for a cumulative amount not-to-exceed \$3,000,000 to provide construction services for Heating, Ventilation, and Air Conditioning work on an as-needed basis at various facilities throughout the Corporation.

- AND -

8. Authorizing the President of the New York City Health and Hospitals Corporation to

execute a requirements contract with Atlas Restoration Corporation for a cumulative amount not-to-exceed \$5,000,000 to provide construction services for General Construction work on an as-needed basis at various facilities throughout the Corporation.

Dr. Stocker introduced and moved for the adoption of the resolutions as a group which was duly seconded and adopted by the Board by a vote of 14 in favor with Rev. Lacey abstaining.

RESOLUTIONS

10. Authorizing the President of the New York City Health and Hospitals Corporation to execute a sublease agreement with Meals on Wheels of Staten Island, Inc., for the development and operation of a facility housing kitchen, office and store functions on the campus of Sea View Hospital Rehabilitation Center and Home.

- AND -

11. Authorizing the President of the New York City Health and Hospitals Corporation to executive a revocable license agreement with the Federal Bureau of Investigation of the United States Department of Justice for its continued use and occupancy of space to house communications equipment at Coney Island Hospital.

- AND -

12. Authorizing the President of the New York City Health and Hospitals Corporation to execute a revocable license agreement with Sprint Spectrum L.P. for its continued use and occupancy of space for the operation of a cellular communications system at Coler/Goldwater Specialty Hospital and Nursing Facility, Goldwater Campus.

- AND -

13. Authorizing the President of the New York City Health and Hospitals Corporation to execute a revocable license agreement with T-Mobile Northeast, LLC, for its use and

occupancy of space for the operation of a cellular communications system at Coler/Goldwater Specialty Hospital and Nursing Facility, Coler Campus.

Dr. Stocker moved the adoption of the resolutions which were duly seconded and unanimously adopted by the Board.

RESOLUTIONS

16. Approving and ratifying bylaws adopted by HHC ACO Inc.'s Board of Directors.

- AND -

17. Authorizing, approving and ratifying certain actions of the HHC ACO Inc. Board of Directors, which authorized that the number of Directors of HHC Inc.'s Board of Directors be fixed at eight and that each of the following persons be elected to serve as Directors of HHC ACO Inc.'s Board of Directors subject to approval and ratification by HHC ACO Inc.'s sole Member, the New York City Health and Hospitals Corporation (the "Corporation"): Jeroman Berger-Gaskin, a Medicare beneficiary Director – A Director to be named pursuant to a designation by a majority in number of HHC ACO Inc.'s ACO Participants, as defined in 42 C.F.R. Part 425, other than the Corporation, that have executed Participations Agreements with HHC ACO Inc., and specified in a writing signed by such majority that is delivered to the Chairman of HHC ACO Inc.; A Director who shall be the Chief Executive Officer of Physician Affiliate Group of New York, P.C. ("PAGNY").

Dr. Ross Wilson, Senior Vice President and Chief Medical Officer, explained that the ACO was formed in response to health care reform to try to provide better care at a

lower cost. He further explained that to achieve this goal the focus will be on four key functions, including promoting better care based on best evidence; working more actively with patient engagement; obtaining higher levels of sophistication on measuring quality and costs together, as well as reporting them in a timely fashion; and, coordinating care by building on the patient centered medical home and the health home initiatives.

Dr. Stocker moved the adoption of the resolutions which were duly seconded and unanimously adopted by the Board.

RESOLUTIONS

3. Authorizing the creation of the HHC Finance Corporation as a Type C not-for-profit corporation under Section 402 of the New York Not-for-Profit Corporation Law with the New York City Health and Hospitals Corporation as its sole member.

- AND -

4. Authorizing: (i) the New York City Health and Hospitals Corporation (the "Corporation") to contribute approximately \$10.661 Million to HHC Finance Corporation (the "Finance Corp") (ii) the directors of the Finance Corp. to authorize its use to make a loan of \$10.661 Million to HHC Investment Fund LLC (the "Investment Fund") to be established by U.S. Bancorp Community Development Corporation (the "MNTC Equity Investor"); and (iii) authorizing the President of the Corporation to borrow \$14.7 Million from HHC/NCF Sub-CDE, LLC, a subsidiary of the Investment Fund, for the Corporation's use to pay a work order from the Dormitory Authority of the State of New York

("DASNY") generated for the Harlem Hospital Center major modernization project (the "Project") all in order to effectuate the participation by the Corporation and the Finance Corp. in a supplemental financing of the Project through a New Markets Tax Credits structure (the "Proposed Financing"); and (iv) the approval and confirmation of all prior actions previously taken in furtherance of the Proposed Financing.

Marlene Zurack, Senior Vice President and Chief Financial Officer, explained that the resolutions were needed to support complex transactions that would provide opportunities for HHC to receive funding for capital projects in low income communities.

Dr. Stocker moved the adoption of the resolutions which were duly seconded and unanimously adopted by the Board.

RESOLUTION

5. Adopting the Corporation's Mission Statement and Performance Measures as required by the Public Authorities Reform Act.

Dr. Stocker moved the adoption of the resolution which was duly seconded and unanimously adopted by the Board.

RESOLUTION

9. Authorizing the President of the New York City Health and Hospitals Corporation to name the Burn Intensive Care Unit on the second floor of Building 6 at Jacobi Medical Center The Stanley M. Levenson, M.D. Burn Intensive Care Unit."

Dr. Stocker moved the adoption of the resolution which was duly seconded and unanimously adopted by the Board.

RESOLUTION

14. Authorizing the President of the New York City Health and Hospitals Corporation to modify the scope and budget for the Major Modernization project at Gouverneur Healthcare Services to add an additional \$38.2 million, raising the total project budget to \$247.479 million.

Dr. Stocker moved the adoption of the resolution which was duly seconded and adopted by the Board by a vote of 13 in favor with Rev. Lacey opposing.

RESOLUTION

15. Authorizing the President of the New York City Health and Hospitals Corporation to modify the Capital budget for the Lincoln Medical & Mental Health Center Emergency Room Expansion and Annex by \$9 million, increasing the total project budget to \$37.3 million.

Dr. Stocker moved the adoption of the resolution which was duly seconded and unanimously adopted by the Board.

BOARD COMMITTEE AND SUBSIDIARY BOARD REPORTS

Attached hereto is a compilation of reports of the HHC Board Committees and

Subsidiary Boards that have been convened since the last meeting of the Board of Directors. The reports were received by the Chairman at the Board meeting.

EXECUTIVE SESSION

The Board convened in Executive Session and discussed matters of personnel.

ADJOURNMENT

Thereupon, there being no further business before the Board, the meeting was adjourned at 6:20 P.M.

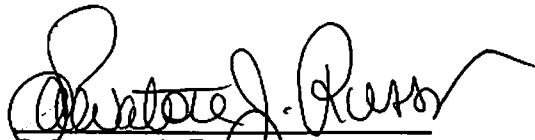
A handwritten signature in black ink, appearing to read "Salvatore J. Russo", written over a horizontal line.

Salvatore J. Russo
Senior Vice President/General Counsel and
Secretary to the Board of Directors

COMMITTEE REPORTS

Audit Committee – September 13, 2012 As reported by Ms. Emily Youssef

Ms. Emily Youssef, Committee Chair, called the meeting to order and introduced the action item for the Audit Committee's consideration:

Resolution - Granting approval by the HHC Audit Committee of the retention of KPMG, LLP, HHC's certified independent public accounting firm, to provide HHC with expert services for ICD-10 readiness preparation unrelated to the HHC audit.

Mr. Salvatore Russo, Senior Vice President & General Counsel introduced Dr. Louis Capponi, Chief Informatics Officer, both presenters of the resolution. Mr. Russo stated that the Public Authority Accountability Act (PAAA) requires that any time there is retention of the independent accounting firm for the agency or a public authority, there has to be approval of the Audit Committee. The underlying concern is that there is no undue influence, and the Audit Committee is aware of the fact that this is going on.

Dr. Capponi stated that the nation is moving from the current coding system, ICD9, which is the clinical coding system used in billing as well as other leads in care, to ICD10. This is a major change that affects all of HHC's operations from a financial as well as clinical perspective, particularly around the billing process. HHC has retained KPMG to assist with an assessment of what are the necessary steps for HHC to move from the current state to the future state. This requirement goes into effect and is mandatory as of October 2014. During the time of procuring this engagement, they had to change their initial rollout period because of the challenges that providers are facing in preparing for ICD10. That was the scope and intent of the solicitation, and there is no auditing in the scope.

Ms. Youssef asked if an RFP went out. Dr. Capponi responded that consistent with HHC's operating procedure, HHC issued a request for proposals from companies that were on contracts that HHC had procured through HHC's approved purchasing organizations. HHC had procured KPMG's services through the state.

Ms. Youssef asked if anyone had anything else.

Dr. Michael Stocker, Board Chairman, asked how long they have been working on the coding system upgrade. To which Dr. Capponi responded six months, but Ms. Youssef asked how long had they been talking about it. Mr. Capponi said that ICD11 is coming out shortly, but it has been 20 years that ICD10 has been in the making and used in many countries. The United States is the last to move forward.

Ms. Youssef asked if there were any other questions and asked for a motion to approve. Motion was approved by the Committee members.

Ms. Youssef thanked them and directed the meeting to Mr. Jay Weinman, Corporate Comptroller, to present the draft financial statements.

Mr. Weinman stated that he will be comparing June 30, 2012 to June 30, 2011 and that he will be referring to two pages, which are the balance sheet and income statements. Overall, the Corporation's net deficit for 2012 increased by \$259 million compared to \$321 million for 2011. KPMG has issued an unqualified opinion, which means that the statements are fairly stated in all material respects. Included in the financial statements is the Management Discussion and Analysis, which will be referred to as MD and A. Mr. Weinman continued by stating that rather than go through the entire financial statement line by line, he is going to highlight the six areas that have significant variances. The first issue is residents FICA refunds. HHC recorded a receivable from the IRS for medical residents that should have been exempted from FICA between 1997 and the first quarter of 2005. HHC recorded \$30 million of FICA refunds and \$27 million in interest for residents employed during that time, HHC also recorded \$19 million for residents and \$17 million in interest. On Other Current Assets, Mr. Weinman said that he is referring to basically the variances between 2012 and 2011. The other current assets received in 2012 are \$135 million compared to \$20 million from 2011. The major variance is \$94 million in FICA refunds that HHC is entitled to, as well as the medical residents, including interest. Further down the page into other current liabilities listed is \$36 million of FICA refunds due the residents which will be returned back to them as, HHC is not entitled to it.

Ms. Youssef asked if out of \$94 million, \$36 million gets paid out as refunds to the residents. To which Mr. Weinman responded yes, they will be paid to the residents.

Dr. Stocker asked if the net comes back to HHC. Mr. Weinman responded - \$57 million, \$30 million for the FICA and another \$27 million in interest.

Dr. Stocker asked how much the share is for the residents if they trained during those years. To which Mr. Weinman responded that some of them will be getting over \$10,000 in refunds. Mrs. Bolus added plus interest. Mr. Weinman stated that some of them may walk away with \$15,000 to \$20,000. In addition the income related to this transaction, under fringe benefits, you will see that as \$1.122 billion. In other revenue under the operating revenue, \$71.271 million includes last year of \$47.519 million and \$27 million of interest.

Mr. Weinman continued by stating that the Corporation entered into a capital lease with North General Hospital campus which will be used to relocate the Goldwater operation. For explanation of that, see note 7J of the statement. The actual transaction is within the financial statement on the balance sheet. He said that the balance sheet merely reports the assets and the liabilities; the income statement reports the expenses and the revenues, that that is why he goes back and forth between the two. Capital assets net of \$3.009 billion, has gone up from last year's to \$2.874 billion. Part of that has to do with the reporting of the capital lease which was reported as capital, so it will increase by \$28 million. Also recorded on page 13 is the long term debt at \$1.025 billion compared to the \$1.039 billion which includes the \$48 million in capital debt that HHC has now for the lease. There are no income or expense implications at this time until HHC starts paying the lease.

Mr. Weinman continued with the next item collective bargaining. The Corporation revised its estimate of unpaid collective bargaining consistent with the City, resulting in a decrease of \$47 million. It is included in the salaries of \$732 million compared to the \$751 million of last year. Personal services is at \$2.435 billion compared to \$2.583 billion, it has gone down related to the \$47 million in collective bargaining reduction. Other decreases related to this difference between 2011 and 2012 are FTEs. They have gone down by 1.3% or 471 FTEs.

Ms. Youssouf asked if the FTEs are included in the reduction. To which Mr. Weinman responded that that is included in the difference as well. Mr. Weinman continued with OPEB. He apologized for going back and forth between pages, but it gives a perspective of the balance sheet and income statement. Ms. Youssouf stated that that was very helpful.

Mr. Weinman stated that on OPEB (Post Employment Benefits other than pension) the liability is at \$4.422 billion. It was adjusted this year for the additional OPEB liability that the New York City Actuary's office had calculated. The net was a \$209 million increase from \$4.218 billion. On page 14 the OPEB is at \$303 million down from \$620 million, that's a decrease of \$317 million. The decrease in expense has to do with the assumptions that have been changed, the demographic, and the salary scale data. On the notes on page 39 the calculation indicates that is actually done actuarially and it shows the negative \$78 million. This is the adjustment this year for the changes in assumptions. In 2011, the change in assumption was \$202 million. So it was a swing of \$280 million between the two years. This is the biggest change between last year's expense and this year's expense. According to the Actuary's office, next year there should not be as much of a swing, but it is somewhat unpredictable unless they change further assumptions. As mentioned before, under net patient service revenue, there is a decrease from \$5.315 billion to \$4.909 billion is due to four big items that have to do with third party payer settlements. This decrease occurred in four areas: DSH maximization of \$138 million; supplemental Medicaid managed care of \$85 million outpatient UPL of \$85 million and the Corporation reserved additional funds for HMO casements, which is a rate adjustment of \$38 million.

Mr. Weinman continued with the final item – MetroPlus pharmacy benefits. It was stated that the pharmacy benefit to MetroPlus, which under the recommendation of the Medicaid Redesign team added to Medicaid Managed Care plans, resulted in \$340 million additional premium revenue. But it also resulted in \$340 million of additional expense as shown under premium revenue other than personal services; an increase in 2012 from \$1.279 billion to \$1.891 billion. The \$340 million difference is the pharmacy revenue. The other difference has to do with 5% membership increase and 9% rate increase. Likewise on the expense, other than personal services, in 2011 is \$1.964 billion compared to \$2.450 billion. That's total increase of \$490 million of which \$340 million of it is pharmacy plus the remainder is a difference in membership increases and rate increases for MetroPlus.

Mr. Weinman stated that this is HHC as a whole. Before MetroPlus, the Other Than Personal Services increase is less than one and half percent. These are the major variances. He asked if anybody had any questions.

Ms. Marlene Zurack Chief Financial Officer stated that they will need the Committee to vote to accept the audited financials at some time in the meeting.

Ms. Youssouf directed the meeting to Mr. Martell. Mr. Martell introduced himself and his team as follows: Jim Martell, Partner, KPMG to his left Camille Fremont, Senior Manager from KPMG and to his right Bennie Hadnott from Watson Rice LLP.

Mr. Martell continued by stating that their role is to present their required communication to the Committee. As they go through it, they will perhaps refer back to some of the financial statements that Mr. Weinman has talked about. Mr. Martell stated that before he starts and turns it over to Ms. Fremont, he would like to say that typically they're sitting at this table September 29th or 30th, getting the information to the City two or three days later; October 1st or 2nd. After the planning meeting when they presented to this Committee back in June, they were informed that the City requested an earlier submission. After meeting with Ms. Zurack and Mr. Weinman he acted like he was not concerned, but he was. Because an acceleration of two weeks for an organization this size, and the detail costing, and some of the transactions that Mr. Weinman talked about relating to the North General transaction, they needed to get their specialists involved. The actuarial report which comes from the City, which at time has not been the timeliest in terms of receipt, he was concerned. All in all, in all sincerity, the Corporation and their staff did a great job in getting KPMG the information well in advance. He stated that he was very impressed in the way they were able to turn it around, provide it for KPMG to be able to get through this.

Ms. Youssouf thanked him for sharing that with the Committee because she knows how difficult it is to put one of these together. She and the Committee think incredibly highly of the Corporation's CFO and KPMG's team.

Mr. Martell stated that both the financial statements and the glossy were handed out in advance. Since then KPMG went through their second partner review, they did some minor changes throughout the footnotes and so forth from what you had originally seen, but nothing substantial.

Mr. Martell directed the Committee to the glossy in front of them which talks about the required communications. It's nothing new and the Committee has seen it over the past several years. It talks about KPMG responsibilities, management's responsibilities and Audit Committee's responsibilities. The most important item that he wants to highlight is what Mr. Weinman mentioned, the unqualified opinion. An unqualified opinion is the highest form of assurance that the numbers are fairly stated. KPMG does not audit every number nor look at every check. KPMG utilizes sampling and most importantly KPMG relies on the management at the top, their internal control over financial reporting. KPMG does not do detail testing, they do analysis, but also spend a lot of time on the estimates. For an organization such as HHC, similar to any other health care organization, the estimates are similar in nature, third party liabilities, patient receivables and pool receivables which fall into the third party. As Mr. Weinman mentioned, the OPEB which is \$4.5 billion is an ungodly large number. KPMG had one of their specialists look at the actuary assumption, and challenged the assumptions. After going through, all that one could argue that the balance sheet is probably 75, 80% estimates and that is a big number. KPMG has to rely that management has a process in place and to give an indication of how good management has done. HHC recorded \$1 billion last year as estimated third party and pool receivables. This year the net difference to the estimate is \$2 million. That's an indication that the Corporation has a pretty good process in place. To say that there is a change of \$2 million out of \$1 billion, that is extremely comfortable in terms of the process.

Mr. Martell continued by stating that they also issued two other reports, a statutory report for MetroPlus which is as of December 31st.

Ms. Youssef asked what he means when he says statutory. To which Mr. Martell responded that it is required under the Department of Insurance for New York State and HHC insurance is similar to that. The second engagement team performs those audits on the six month period for MetroPlus through December 31st. They perform all audit procedures, issue analytic review, and additional testing for December through June.

Mr. Martell turned the presentation to Ms. Fremont.

Ms. Fremont began by stating that slide five laid out the different judgments and accounting estimates imbedded within the financial statements. The first area where there are estimations is the valuation of given accounts receivable. In order to gain comfort over the process, we update our understanding of both the patient revenue and cash receipt cycle and perform certain tests of controls. In order to validate and be comfortable over management's process of evaluation, we selected three facilities for both their inpatient and outpatient accounts receivable. We utilized our computer assisted auditing tool in order to ensure that management's process is still operating appropriately, and could be relied upon. Additionally, we do certain ratio analysis to understand the changes year over year, we will look at your aging components, will look at the financial data and ultimately we were able to conclude that the patient accounts receivable practice was reasonable as of June 30th.

Ms. Youssef asked if that is reasonable based on peers. To which Ms. Fremont responded that it is reasonable based on how your accounts settled out. Management needs to estimate how much of your receivable would you collect, this is the net accounts receivable. They also figure out what percentage of your gross charges will be contractual allowances versus bad debts or write-offs. That's where KPMG come up with reasonableness.

Mr. Martell added that the issue as compared to peers is what management supplies us with what we think they are going to collect, roughly \$450 million, \$470 million, subsequent to June 30, 2012. That is the number we audit. When you start comparing write-off to peers, we do it in terms of day's receivable. Mr. Martell thinks this year is roughly 54 or 56, that number of what is compared to the peers. Some organizations are in the forties which do not mean that they are collecting receivables any faster, it means they are valuing lower. When you compare yourself to peers and look at the industry data, you sometimes need to take a step back and understand how each organization does it. In his view 55 or 56 days is not as bad, it is actually pretty good for an organization the size of HHC with over \$5 billion in revenue.

Ms. Zurack added that the state is average 65 and she thinks that the term reasonableness is to get a pure answer to the question. Basically, it is saying that it is accurate within reasonable corridors. They can't certify it to the 13th digit because it is an estimate.

Ms. Fremont continued on to the next area and said that she will briefly touch on in slide five is the Corporation's estimated third party payor settlements. She said that they did review all significant reimbursement professional tests discussed in this review. Then as Mr. Martell pointed out previously, there was a change in the prior year estimate for \$2.5 million. As a result of the review they are comfortable with the appropriateness of the receivables that are booked within the balance sheet.

Ms. Fremont stated that the next area that both Mr. Martell and Mr. Weinman have spoken about is HHC's OPEB liability. As previously mentioned, we do utilize an actuary to look at the actuarial assumptions within the report and determine their reasonableness. KPMG's internal actuary did find that the assumptions were reasonable. We also performed an actual test tract over the census data, which is the participant data that goes into the calculations from the actuary. We did find some small discrepancies for date of birth and membership participation between the information that is provided and what the Corporation's internal records show. Based on discussions with KPMG's actuaries, we were able to conclude that those discrepancies would result in a minimal impact to the financial statements. Again KPMG is comfortable with the liability as presented within the financials.

Ms. Fremont continued by stating that the next area they spent time looking at is MetroPlus. They have what is called incurred but not reported liability. Management does have an actuary review of this liability. It goes back to December 31st for the statutory statements and then at June

30th. At December 31st, KPMG actuary reviews those actuarial assumptions and determine their reasonableness. Then for June 30th KPMG performed control procedures of all the controls for the period from December 31st to June 30th, 2012. Again they were to conclude that KPMG is comfortable with the balances in the IBNR liability.

Mr. Martell said that the IBNR estimate as of June 30th was roughly \$86 million, now it is up to \$112 million. As Mr. Weinman mentioned you would expect that increase in terms of an increase in membership and also payments. The membership has reached roughly 405,000 members for the 2011 year, for the 2012 year, it averaged about 425,000 members per month. That is a 20,000 member per month increase which is 5%, because of these numbers we would expect revenue and also would expect medical services throughout the organization to up as well.

Ms. Fremont continued to slide seven where they laid out various other areas that they spent time throughout the audit. The first one is the Physician Affiliate Group of New York (PAGNY). In the current year, the Corporation did engage PAGNY at various facilities. As a result of the growing business of PAGNY, we were told to analyze whether or not PAGNY should be consolidated within the financial statements of HHC. Based on our review of the Articles of Incorporation and the by-laws of PAGNY, as well as the agreement between HHC and PAGNY, we concluded that management was correct, and that PAGNY should not be consolidated inside HHC's financial statements. Mr. Weinman briefly touched upon the reporting of the North General lease, once again, that resulted in a capital lease on the balance sheet of the Corporation approximately \$48 million, which is the present value of the minimum lease payments. Mr. Weinman also spoke about the FICA receivables, which we will not go into detail.

Ms. Fremont stated that they do review information technologies. They go over such general controls as well as application controls around access to program and data, HHC's program changes, computer operations and concluded that the general controls surrounding information technology were operating effectively.

Ms. Fremont continued with slide eight where there are various other required communications. HHC's accounting policies have been consistently applied. We have not been made aware of any consultations with other accountants regarding the application of accounting policies. KPMG did not encounter any significant difficulties during the course of the audit and is not aware of any material errors, fraud or illegal acts that would result in significant misstatement of the financial statements. There was an audit adjustment that had to do with the \$94 million FICA receivable which Mr. Weinman spoke about that was booked within the financial statements. KPMG received the full cooperation of management and did not have disagreements with them.

Ms. Fremont moved on to slide nine by stating that as they released their audit for 2012, they are independent with respect to the Corporation's various rules and regulations. Also on slide nine are the Corporation's non-GAAP policies, these are the same non-GAAP policies that from previous years. There are no new non-GAAP policies, and these are all inconsequential to the financial statement as a whole.

Ms. Fremont continued to slide ten - she stated that as required they consider fraud throughout the audit. As a result of identifying potential fraud, they then respond to the identified fraud by testing certain controls. KPMG again utilized their computer assisted tool to perform journal entry routines, to make sure that the manual journal entries are being recorded properly. They will scan for certain items such as ending 999, or various other items that the literature would say are potential areas of concern. Mr. Martell added that these are things where there is no support, obviously nothing was found. Ms. Fremont stated that then they also conduct interviews of various members of the Corporation listed on slide 10.

On slide 11 Ms. Fremont continued on the various reports that are issued as part of the fiscal year 2012 contracts. KPMG reports on the basic financial statement of the Corporation. As previously mentioned, there are stand-alone financial statements done for the Corporation's two insurance companies; the insurance company and the health plan and they will issue a management letter. Mr. Martell added that a copy of the letter will be supplied to Dr. Stocker and Ms. Youssouf next week. Typically, the last two or three years KPMG has tried to bring a draft to this meeting, but because of the acceleration, he feels it was more important to get the financials to the City tomorrow. Ms. Fremont stated that then they will also issue certain agreed upon procedures as they pertain to beds and charity care, as well as cost reports. The last page of their glossy presentation is just resources available to members of the Audit Committee.

Mr. Martell stated that that concludes their presentation as it relates to the required communications. If there any questions related to the presentation or the financial statements, he'll be happy to answer them.

Ms. Youssouf asked if there were any questions and asked for a motion to accept the financial statements, it was seconded and approved the Committee members present. She thanked KPMG and directed the meeting to Mr. Telano for an internal audit update.

Mr. Telano saluted everyone and stated that the only report he is going to discuss today is the audit of the Accounts Payable at Central Office. The objectives of the audit were to ensure that corporate policies and procedures are adhered to and that adequate internal controls existed. In order to evaluate the internal controls, we looked over the process related to accounts payable and the vendor setup. We ascertained if there were any weaknesses, then we asked why the weaknesses occur. We then determine what the risk is and what should be done to correct it. As I go through each section, I am going to point out what the risk is and what was done to correct it. As I mentioned, it is a two pronged audit; material management and accounts payable, Corporate Accounts Payable at Central Office.

Mr. Telano stated that he will talk about Material Management first. I want to point out that Material Management is a clerical function, it is not a control. Although it is centralized, it is clerical in nature. The first comment that we have has to do with employees being set up as vendors, sometimes it occurs because of reimbursement of expenses. The way that they are supposed to set them up is through the payroll system using their social security number, and then it interfaces over to the vendor listing. However, we found quite a few instances in which vendors were being set up through the vendor module and not through payroll. As a result, these employees can be issued a 1099 form. Also, their social security number is available to individuals. The Corporate Comptroller and Material Management have been taking the necessary steps to address this. Material Management was developing a check box on their forms when new vendors are set up asking if this is an employee. If they say yes, they are supposed to through payroll. Then the Corporate Comptroller will remind the facilities, the accounts payable personnel and other relevant personnel to ensure that these employees are set up through the payroll module.

Mr. Telano continued by stating the other issue related to Material Management, is that their staff had access to systems options not related to their function. They are able to enter and modify requisitions and purchase orders, validate vendors and other receiving entries. They could possibly set up a requisition, make a purchase order and then set up the vendor. In many instances, the reason these employees have this access was because they had previous positions and their access levels were not changed. Also, the access was given because it was soup to nuts when they came on board.

Mrs. Bolus asked how many people were involved and Mr. Telano responded that he believes it was four or five. This is just dealing with vendors corporate-wide. Material Management quickly resolved it and has changed everyone's access.

Ms. Youssef stated good. Mr. Telano asked if there were any questions regarding these two areas. He then continued with Accounts Payable. The first issue has to do with the payees again, going back to third party payees which are employees. The Accounts Payable Director and staff had the ability to modify the payee data and make payments to these payees. The AP Director has the ability to create a requisition and purchase order in that system, but that is a separate thing. Going back to the payee, the problem now is that they have the ability to enter and modify payee data, but after they modify it defaults back to the original name. For example, if there's a check made out to my name Chris Telano, someone from Accounts Payable could change that check to their name. The check would be cut in their name. However, in the interface, it would default back to my name. If you look at all the historical data, you would see that check was made out to me, but when it was printed, it was made out to whatever name you could fill in. We think that the people in Accounts Payable should not have the ability to modify the payee information.

Dr. Stocker asked why it set up that way is. Mr. Telano answered that he did not know.

Ms. Youssef asked if he knew how long has been set up this way. Mr. Telano responded that he did not know.

Ms. Youssef asked Mr. Weinman. Mr. Weinman stated that although sometimes the name will revert back to the original name, they do check every payee on each check to make sure that who we pay is actually who the check was cut to. They call that payee verification and they do that on every check.

Ms. Youssef asked how they do that. To which Mr. Weinman responded that they do that electronically, files are sent to the bank and the bank compares the file that comes out of accounts payable to what was actually paid. If there is a fraudulent name on there, we would catch it. The problem is that while we can make changes to the payees, and we typically do it for a third party payor, or there is an IRS tax levy we will add a third party. The IRS would get paid, and the vendor may only get paid a penny, that is one of the limitations of the system. There is no way of actually detecting how many of these third party payers were paid. We have to work with our programmers to write a report so we can identify them separately. Currently it is a function that accounts payable needs in order to pay vendors, especially when there are tax levies, but there is no method within the system to detect that in the current forms.

Mrs. Bolus asked if they are aware that they are doing this. Mr. Weinman responded yes and the vendors who have tax levies or whatever it is as well.

Ms. Youssef asked if Accounts Payable is in the process of trying to get this fixed and Mr. Weinman responded that he did not know if it is a system fix or just a report that they could monitor on a weekly basis. He said he was checking on it.

Ms. Youssef stated to please let them know.

Mrs. Bolus asked if there a possibility that a check could be paid out on Monday and you won't find out about it until Friday. Mr. Weinman replied that they do monitor checks on a weekly basis. They could run weekly reports unfortunately there were checks that are cut at the facilities that could be done independently. This audit was done at Central Office, the checks are run weekly.

Mr. Telano continued by stating that the other internal control issue they found is that the Accounts Payable Director has basically unfettered access to the entire payable process. She processes the vouchers, she prints out the checks, and she retains custody of the checks until they are either picked up or until they are mailed. We found that that is a lack of segregation of duty, which basically has been a red flag in all auditing realms. We suggested that someone else be part of that process and to take a step away from her. Mr. Telano stated that he is not implying anything because we did not find anything nor was our audit geared towards fraud. However, there are two elements of fraud;

opportunity and motive. We would like to take the opportunity away and we would also like to deal with preventive controls over the detective controls. The control that Mr. Weinman was mentioning before is after the fact, which is detective. However, we would like to encourage preventive controls. This way, things are resolved up front, and we are always looking to resolve the risk. In this particular case, Mr. Weinman can speak on that, they have a staffing issues, and they are not able to delegate some of these functions to other individuals in Accounts Payable.

Ms. Youssef asked if it's because the AP Director and the entire AP staff have the same access. Mr. Weinman replied that they have the Director and two other full time staff. They have two temporary staff in there, but at this point, one is out on sick leave almost a year. They basically run the department with three full time staff. It is problematic because all three staff has to assume all the duties within Accounts Payable. There isn't an individual that we can segregate and say that you can only do distribution or you just cut checks, we use the people interchangeably within the functions. Mr. Weinman stated that they have already implemented a periodic check, every week, we check through about five vouchers to make sure they are valid and Mr. Linhart, one of the deputy controllers does that himself.

Ms. Youssef asked if this is done at random and Mr. Weinman responded he chooses high amounts at random and the others are at random as well to ensure that the packages are complete and appropriate.

Ms. Youssef asked if they were able to hire another person would help, it does seem like it is kind of an Audit 101. Mr. Weinman responded by stating that he did not believe that they need to hire somebody. He thinks that they minimize the risk currently by doing the random check. The amount of work that has to get done is getting done with the current staff and it is supplemented by temporary help because there is one on sick leave.

Ms. Youssef asked if the temporary help have access. Mr. Weinman said no, and we want to keep control of the process within our own staff. We are getting temporary help for the actual distribution process. There is a log book and we keep control and account of every check that goes out the door. This is controlled by the Director and if she is not around, one of our full time employees.

Ms. Youssef stated that that is her concern that people leave, or something changes. Ms. Zurack replied that she thinks that they are trying to look at putting in terms of downsizing the finance staff from 129 to 118 people, they lose some major functions. They are trying to look for creative ways, even Accounting 101, which was written in 1952. Ms. Youssef stated that there is nothing wrong with things that came from 1952.

Ms. Zurack stated that there is nothing wrong with improving 60 years later and they are trying to figure out creative ways to solve this. Mr. Weinman said that he is very confident that he does not have the need of this. The 1952 rule book said the second we pull it, detect versus prevent, he is doing the detect, which means he going to detect it. He has not detected anything, and is much cheaper and more efficient to do it that way. Obviously new technology would be helpful, we are looking at that option as one of the long term solutions, and it is very hard for us to justify any new FTEs at this level.

Ms. Youssef explained that Mr. Telano pointed this out as something that should be addressed and that she understands where Mr. Weinman is coming from. She also understands that Ms. Zurack is doing the best with the resources she has. However, there should be a discussion between Mr. Telano and Ms. Zurack at some point. If it's deemed that it is not the best fiscal policy, this may be one area where adding someone may make sense. From a financial damage point, it needs to be explored a little more.

Ms. Zurack said to Mr. Telano that he never came to her to say that she's got a big risk and she asked him if she did. To which Mr. Telano replied that it is a risk, if he thought it was a very big risk he would have brought it to her attention. He said that it is a risk in that one person has full control of the process. That is always a risk. He was not asking for additional staff, he was asking that instead of having one person that controls step one through ten, add someone at perhaps, step number seven, for instance. Wherever the step might be, then the other person can break it up a little bit, that is all that is being recommended.

Mr. Martin stated that he thinks there should be a conversation that this can be resolved. That he certainly has a lot of confidence in Ms. Zurack and Mr. Weinman. Ms. Youssef agreed and Mr. Martin also stated that he also thinks that Mr. Telano does a good job that he thinks a subsequent meeting would help.

Ms. Youssef stated that she would encourage them to do that.

Mr. Telano continued with a couple of other issues. He stated that although the OTPS system is able to recognize duplicate invoice numbers upon input, it is very sensitive to the data that is input. For example, if an invoice was already in the system as number 123, if the same invoice came in and somebody input 123, and hit the space bar by accident, the system would accept it. He thinks that it needs to be corrected. Number two, there is no consistent manner of the input of invoice numbers, if the invoice number is a date or missing. We would like the Accounts Payable to come up with a system in which it is consistently input by all the Accounts Payable staff. He knows that Mr. Weinman is looking into that and they are going to be writing up a policy establishing unique invoice numbers for when those types of situations occur. The last comment has to do with the voucher caps. Basically the cap is a warning mechanism that is set very high. It alerts key individuals that they should take a look at this. The voucher cap was at \$10 million. However, there are very few items for \$10 million. We suggested that they

reduce that, this way it provides them with more of an opportunity to review high dollar checks. They did implement that, and Mr. Weinman's response was that it resulted in 20 percent of the voucher dollar being reviewed. Mr. Telano asked if there were any questions.

Ms. Youssouf said to Ms. Zurack and Mr. Weinman that she does not want them to believe that she was criticizing what they do, but a little further discussion would be helpful. Then she announced an Executive Session to discuss matters of potential litigation issues to HHC.

Ms. Zurack said that she failed to acknowledge Marshall Bondy who is in the room. Mr. Bondy and Mr. Weinman are the team that got the two weeks off of the time frame for the financial statements. There was a lot of innovation, and she wants Mr. Bondy to get full credit for that because the guys in the background don't always get it.

Ms. Youssouf thanked Mr. Bondy.

Ms. Youssouf then indicated that the Committee was going into Executive Session. (Executive session was then held).

After returning to public session Ms. Youssouf asked if there any old business or new business. If not she asked for a motion to adjourn.

Capital Committee – September 13, 2012
As reported by Ms. Emily Youssouf

Assistant Vice President's Report

Alfonso Pistone, Assistant Vice President, Office of Facilities Development, advised members of the Committee that the afternoon's agenda was extensive, including nine (9) action items, four (4) information items, and one (1) order of old business pertaining to a license agreement that was previously approved by the Capital Committee but not forward to the full Board due to delays in Vendex approval.

Mr. Pistone explained that there would be no delay reports provided as there had been no significant changes or other circumstances related to the progress of those projects previously reported.

That concluded his report.

Action Items:

Authorizing the President of the New York City Health and Hospitals Corporation (the "Corporation" or "Landlord") to execute a sublease agreement with Meals On Wheels of Staten Island, Inc. (the "Tenant" or "Meals On Wheels"), for the development and operation of a facility housing kitchen, office, and storage functions on the campus of Sea View Hospital Rehabilitation Center and Home (the "Facility").

Angelo Mascia, Executive Director, Sea View Hospital Rehabilitation Center and Home, read the resolution into the record on behalf of Arthur Wagner, Senior Vice President, Southern Brooklyn/Staten Island Health Network. Mr. Mascia was joined by Joe Tornello, President, Meals on Wheels, Staten Island.

Mr. Mascia explained that Meals on Wheels is a not-for-profit organization that provides meals to seniors. He advised that their present location does not have adequate kitchen space needed to provide necessary services and that the centralized location of the Sea View campus, in the Borough of Staten Island, would be an ideal location.

Mr. Mascia noted that the agreement would provide for an approximately 65,000 square foot parcel of land for construction of a new kitchen, some parking spaces and a small number of offices for Meals on Wheels, Staten Island. The lease amount would be \$95,000 per year with annual increases of three (3) percent.

Ms. Youssouf asked whether construction, maintenance etc., would be included, whether it would be a triple-net-lease. Mr. Mascia said yes, there would be no additional cost to HHC.

There being no further questions or comments, the Committee Chair offered the matter for a Committee vote.

On motion by the Chair, the Committee approved the resolution for the full Board's consideration.

Authorizing the President of the New York City Health and Hospitals Corporation ("the Corporation" or "Licensor") to execute a revocable license agreement with the Federal Bureau of Investigation of the United States Department of Justice (the "Licensee") for its continued use and occupancy of space to house communications equipment at Coney Island Hospital (the "Facility"). Current agreement expires September 30, 2012.

Daniel Collins, Director, Coney Island Hospital, read the resolution into the record on behalf of Arthur Wagner, Senior Vice President, South Brooklyn/Staten Island Health Network. Mr. Collins was joined by Dion Wilson, Assistant Director, Office of Facilities Development.

Mr. Collins advised that the license agreement would continue to allow the Department of Justice to house equipment in the mechanical room and on the rooftop of Coney Island Hospital. Ms. Youssouf asked whether this was a renewal. Mr. Collins said yes.

There being no further questions or comments, the Committee Chair offered the matter for a Committee vote.

On motion by the Chair, the Committee approved the resolution for the full Board's consideration.

Authorizing the President of the New York City Health and Hospitals Corporation (the "Corporation") to name the Burn Intensive Care Unit on the second floor of Building 6 at Jacobi Medical Center (the "Facility") "The Stanley M. Levenson, M.D. Burn Intensive Care Unit".

Hannah Nelson, Associate Executive Director, Jacobi Medical Center, read the resolution into the record on behalf of William Walsh, Senior Vice President, South Brooklyn/Staten Island Health Network.

Ms. Nelson noted that it was her pleasure to present the resolution for the renaming, as she had the honor of personally knowing Dr. Levenson. Ms. Nelson explained that while Dr. Levenson was known for seminal scientific discoveries that translated into practical applications and benefitted burn and surgical patients, it was his generous spirit that made him such a respected individual. She advised that Dr. Levenson, worked for the Corporation into his eighties and often times stayed in on campus residence to ensure availability for morning rounds, teaching and crisis management.

Ms. Nelson stated that while Dr. Levenson was wholly respected for his mind and his work he was an outstanding person. He was soft spoken and kind with noted medical accomplishments that supported pioneering work and new fields of healing, with a personality that allowed him to see only the best in others.

Ms. Nelson advised that she believed all requirements for a naming had been met in accordance with Operating Procedures, and that she, on behalf of the facility, respectfully requested approval.

Antonio Martin, Executive Vice President, advised that while he did not know Dr. Levenson personally he was aware of his impressive reputation.

There being no further questions or comments, the Committee Chair offered the matter for a Committee vote.

On motion by the Chair, the Committee approved the resolution for the full Board's consideration.

Authorizing the President of the New York City Health and Hospitals Corporation (the "Corporation") to execute a requirements contract with Rashel Construction Corporation (the "Contractor") for a cumulative amount not-to-exceed \$5,000,000 to provide construction services for General Construction Work on an as-needed basis at various facilities throughout the Corporation.

Authorizing the President of the New York City Health and Hospitals Corporation (the "Corporation") to execute a requirements contract with Volmar Construction, Inc. (the "Contractor") for a cumulative amount not to exceed \$3,000,000 to provide construction services for Heating Ventilation and Air Conditioning (HVAC) work on an as-needed basis at various facilities throughout the Corporation.

Authorizing the President of the New York City Health and Hospitals Corporation (the "Corporation") to execute a requirements contract with Atlas Restoration Corporation (the "Contractor") in the amount of \$5,000,000 to provide construction services for General Construction Work on an as-needed basis at various facilities throughout the Corporation.

Peter Lynch, Senior Director, Office of Facilities Development, read all three requirements contract resolutions into the record.

Ms. Youssouf asked whether the proposed contractors had previously held contacts with the Health and Hospitals Corporation (HHC). Mr. Lynch advised that all three contractors had previous experience with HHC, and that all three contracts had recently been publicly bid, and these three firms were the low bidders.

Josephine Bolus, RN, noted that the first and third resolutions for Rashel Construction Corporation and Atlas Restoration Corporation were quite similar, both for general construction services, and asked for an explanation. Mr. Lynch explained that this allowed for more than one firm at a time to be available for work, noting that a facility could use whichever is available or whichever they may have a good working relationship with.

Ms. Youssouf asked if they were located in different boroughs. Mr. Pistone said yes.

There being no further questions or comments, the Committee Chair simultaneously offered the three (3) items for a Committee vote.

On motion by the Chair, the Committee approved the resolutions for the full Board's consideration.

Authorizing the President of the New York City Health and Hospitals Corporation (the "Corporation") to execute a revocable license agreement with T-Mobile Northeast, LLC, (the "Licensee"), for use and occupancy of space for the operation of a cellular communications system at Coler-Goldwater Specialty Hospital & Nursing Facility, Coler Campus (the "Facility").

Robert Hughes, Executive Director, Coler-Goldwater Specialty Hospital and Nursing Facility, read the resolution into the record on behalf of Lynda Curtis, Senior Vice President, South Manhattan Health Network, who was also present at the table.

Mr. Hughes advised that a resolution for a license agreement with the vendor had been presented and approved by the Board in February 2012, but that resolution had inaccurately listed the first year occupancy rate, as \$52,840 effective November 2013, when in fact the first year occupancy rate is to be \$50,801, effective October 1, 2012.

Ms. Youssouf asked if that was the only difference. Mr. Hughes said yes, all other details of the agreement are the same.

There being no further questions or comments, the Committee Chair offered the matter for a Committee vote.

On motion by the Chair, the Committee approved the resolution for the full Board's consideration.

Authorizing the President of the New York City Health and Hospitals Corporation (the "Corporation") to modify the scope and budget for the Major Modernization project at Gouverneur Healthcare Services (the "Facility") to add an additional \$38.2 million, raising the total project budget to \$247.479 million.

Mendel Hagler, Executive Director, Gouverneur Healthcare Services, read the resolution into the record on behalf of Lynda Curtis, Senior Vice President, South Manhattan Health Network, who was present at the table. Mr. Hagler and Ms. Curtis were joined by Paul T. Williams, President and Chief Executive Officer, John Pasicznyk, Managing Director, and Steve Curro, Regional Director, Dormitory Authority of the State of New York, Paul Anderson, Executive Vice President and General Manager, Hunter Roberts Construction Group, and Dean Moskos, Office of Facilities Development.

Ms. Youssouf advised that while the Modernization project had been discussed on numerous occasions, it was the hope of the Committee that the significant increase in project budget could be better explained and more details could be provided.

Mr. Williams expressed the Dormitory Authority of the State of New York's (DASNY's) commitment to the project and their long standing relationship with HHC. He advised that he, and his DASNY colleagues, were present to assist in explaining how program changes, errors and omissions, fee escalations, general conditions relating to the extension of the schedule, as well as the need for additional contingency were all factors in the escalated project budget.

Ms. Youssouf asked for more detail on why the project budget had escalated. Mr. Pasicznyk noted that various factors had resulted in the project budget increase. For instance, the inclusion of Furniture, Fixtures, and Equipment (FFE) to the project, added an extra \$25 million, and accounted for some bid overages. He added that a significant number of unexpected field conditions had been discovered and those led to additional project delays, and he advised that the original contingency of \$14 million had been virtually exhausted.

Mrs. Bolus requested a less general explanation and asked for some specifics. Ms. Youssouf agreed and asked for a few examples of some of the bigger issues that impacted the project.

Mr. Pasicznyk explained that one significant issue was that in the original project scope it was intended that a number of internal systems would be reused but after the walls were opened up it was discovered that much of the existing piping needed to be replaced and could not be reused. Therefore, what was supposed to be a renovation project ended up being a major infrastructure project.

Ms. Youssouf asked how something like that happens. Mr. Curro advised that in an existing facility, that is occupied, it is difficult to tear into the walls and see exactly what type of infrastructure is there. Instead, a number of other documents are utilized, such as as-built drawings, to assess the situation without destructive testing. Assumptions are then made from that information, and an anticipated budget is drafted based on those assumptions.

Mr. Pistone said that he believes, in retrospect, that a better conditions assessment could have been done to determine the existing condition of the facility. He advised the committee that future construction projects would ensure that original conditions assessments are more thorough, which should result in more accurate project estimates with minimal surprises.

Ms. Youssouf noted that Mr. Pistone was working on making some changes on how construction projects will be presented up front, and asked that the Committee be kept abreast of those changes.

Mr. Williams agreed that the design review process could have been addressed differently and advised that DASNY would be reviewing the fees they received, how those fees relate to various troubled parts of the project, and advised that DASNY is prepared to sit down with HHC representatives to discuss possible adjustments they can make in support of the project.

Ms. Youssef noted that was a very generous offer and said that she looks forward to seeing the outcome of those discussions. She then asked the representative from Hunter Roberts whether they would be doing anything similar. Mr. Anderson said yes. He said that Hunter Roberts greatly values its relationship with both HHC and DASNY, and would be holding a meeting in the coming week to discuss fees and possible adjustments.

Ms. Youssef thanked Hunter Roberts and DASNY for their show of good faith.

Michael Stocker, MD, acknowledged that there was enough blame to go around but noted that moving forward these projects have to be managed better.

Mr. Martin thanked all parties for their cooperation and told the Committee that moving forward he would guarantee there would be a tighter process.

There being no further questions or comments, the Committee Chair offered the matter for a Committee vote.

On motion by the Chair, the Committee approved the resolution for the full Board's consideration.

Authorizing the President of the New York City Health and Hospitals Corporation (the "Corporation") to modify the Capital budget for the Lincoln Medical and Mental Health Center Emergency Room Expansion and Annex by \$9 million, increasing the total project budget to \$37.3 million.

Iris Jimenez-Hernandez, Senior Vice President, Generations+/Northern Manhattan Health Network read the resolution into the record. Mrs. Hernandez was joined by William Hicks, Deputy Executive Director, and Louis Iglhaut, Associate Executive Director, Lincoln Medical and Mental Health Center, and Dean Moskos, Director, Office of Facilities Development.

Mrs. Hernandez advised that when planning for the project initially began several years ago, it was envisioned as a two phase project, the first phase being the annex, and the second phase being the emergency room. Mrs. Hernandez noted that when the annex portion of the project was finished it was then repurposed to accommodate staff that had been reassigned to the Network. She explained that the purchase of equipment, furniture, computers, phones, etc., was originally intended to be paid for using Other Than Personnel Services (OTPS) funding, which is no longer allowed. She said that the facility is now asking for those dollars in Capital funds instead of OTPS.

Ms. Youssef asked whether the original allocation was from another source and so this request was simply shifting funding, and if so, whether the capital budget is prepared to absorb this. Mrs. Hernandez and Mr. Martin said yes, respectively.

Dr. Stocker asked when completion is expected. Mrs. Hernandez said December 2013 but hopefully earlier if possible. The Committee members expressed their excitement in seeing the completed project.

There being no further questions or comments, the Committee Chair offered the matter for a Committee vote.

On motion by the Chair, the Committee approved the resolution for the full Board's consideration.

Information Items:

Goldwater North – Major Modernization – Status Report

Lynda Curtis, Senior Vice President, South Manhattan Health Network, Robert Hughes, Executive Director, and Michael Buchholz, Senior Associate Executive Director, Coler-Goldwater Specialty Hospital and Nursing Facility, and Dmitri Konon, Zachary Smith, and Emil Martone, New York City Economic Development Corporation were all present for the status report.

Mr. Hughes advised that the project was moving forward quite nicely and thanked LaRay Brown and Alfonso Pistone, and their respective staff members for all their leadership and assistance. He noted that the project is moving at an impressive but responsible rate as the completion date nears. He added that the project was on schedule and on budget and it is anticipated that any and all programmatic goals will also be met.

Mr. Martone presented a power point presentation featuring photographs showing progress on both the existing Long Term Acute Care Hospital (LTACH) and the construction of the Skilled Nursing Facility (SNF), as well as other project information. Mr. Martone advised that effective project coordination had assisted in the smooth progress of the project.

Mr. Martone explained that the frame is up for the SNF and within a couple of weeks the façade would be going up. He noted that while construction on both sites began in January of 2012, an impressive but responsible pace is being maintained.

Mrs. Bolus asked how many units would be in the site. Mr. Martone said there would be 164 beds.

Regarding the LTACH, Mr. Martone stated that exterior façade work is taking place, including the whole building being re-pointed, bricks being repaired, and replacement of the roof. Mechanical demolition is taking place, despite being only approximately 20 years old, many of the existing mechanical systems were found to be in disrepair and past their useful life. He explained that work is ongoing to replace a large majority of the systems and to rehabilitate others. Additionally, he advised that when some of the walls were opened up, mold conditions were found, from various causes, but that all visible mold had been abated and walls were being put back in place.

Mr. Martone reviewed budget figures advising that of the total \$284,492,000 project budget, approximately \$46 million had been spent to date, or roughly 16%, commensurate with the amount of work completed. He explained that the contingency of \$20 million was almost entirely intact, with approximately \$18 million remaining. Ms. Youssouf asked if that contingency was enough. Mr. Martone said yes, noting that about 14% of the project budget had been set aside for contingency on the trade portion of the project. He added that procurement was 87% complete, and should be 95% complete by November, with the remaining trades being all interior.

Mr. Martone continued his report by introducing the SNF portion of the project, which he advised should be weather proofed by December 1, 2012, so that workers would be unaffected by the winter season, which would permit moving on to interior fit out work.

Mr. Martone advised that the Institute of Family Health (IFH) which occupies space on the first floor of the building, is scheduled to move out by the first of the year, as anticipated.

He noted that the project was on schedule for a November 1, 2013 move in, and that although there may be some risks moving forward, the team is confident that they are prepared should any issues arise.

Mrs. Bolus asked when the deadline is for vacating the Goldwater site. Mr. Hughes said December 15, 2013.

Ms. Youssouf asked about security at the site. Mr. Martone advised of an arson incident where a crane outside of the SNF had been set ablaze and explained that as a result, security has been increased. He said that there are security cameras installed throughout the area, lighting and alarms have been placed around the perimeter, and two uniformed, off-duty, New York City Police officers on overnight duty, seven days a week.

Ms. Youssouf asked about lead time for moving patients. LaRay Brown, Senior Vice President, Corporate Planning, joined the discussion to address the issue. Ms. Brown noted that while completion is not expected until November 2013, "activation planning" is already being done with a subcontractor to put in place a floor-by-floor outline of how residents and patients will be moved from both the nursing and hospital areas. She noted that the plan needs to be submitted to the State for approval and advised that the team is comfortable with the organization assisting with the plan. Ms. Brown advised that they are involving all staff as well as EDC to assist and ensure proper coordination. She explained that a group is in place to coordinate decommissioning of the existing building, and that group would be enlisting an organization to assist with that process. She noted that the project involves not just movement of people, but of things, such as lab equipment, furniture, etc. Those things must be relocated or gotten rid of in order to leave behind a virtually empty building.

Ms. Youssouf thanked everyone for their hard work on the project and noted that although things got off to a rocky start she was pleased to hear that all is moving forward smoothly.

Mrs. Bolus asked if it was possible to get the Community Advisory Board (CAB) involved in the move. Ms. Brown explained that the CAB, as well as patient families, have been aware of timelines and they are being kept informed.

Mrs. Bolus asked about contention regarding the new construction. Ms. Brown asked whether Mrs. Bolus was thinking of the new construction that is to take place near Metropolitan Hospital Center. Mrs. Bolus agreed. Ms. Brown said she remembers the Committee's interest in that issue and advised that she would keep them up to date.

Queens Hospital Center – Relocation of "T" Building Occupants

Robert Rossdale, Deputy Executive Director, Queens Hospital Center provided an overview of the project. Mr. Rossdale was joined by Julius Wool, Executive Director, Queens Hospital Center.

Mr. Rossdale explained that the "T" building was a 74 year old structure in disrepair that would require significant capital investment to keep running. He noted that approximately 30,000 square feet of roof repair would be needed, in addition to other work, and the cost to operate the building is estimated to be around \$2 million year. Completing work necessary to bring the building up to code would cost approximately \$50 million. He advised that vacating the structure and relocating its occupants in phases, to both on and offsite alternate locations would be approximately \$6.5 million. He advised that DASNY would assist in coming up with a more detailed estimate, including renovation costs. Ms. Youssouf asked what renovations he was referring to. Mr. Rossdale explained that some renovations would be required in existing spaces in order accommodate people and services vacating the "T" building.

Mr. Rossdale advised that approximately 25,000-30,000 square feet of space had already been identified as available for "T" building

occupants. Mr. Martin explained that the Ambulatory Care Pavilion at Queens Hospital Center had been constructed as shell space and so it had some square footage available that could be built-out. Mr. Rossdale added that the Children's Psychiatric Emergency Program (CPEP) site also had some shell space available, and there is also a modular structure on campus that was originally designed as swing space but will now provide space for relocation.

Ms. Youssouf asked if there was any patient space in the "T" building. Mr. Rossdale said there are no inpatient programs or services and noted that two of the three outpatient programs would be moved off-site. He advised that a rough plan had already been mapped out and estimated and that DASNY would then come in to confirm estimates and speed up and oversee various phases.

Ms. Youssouf inquired as to whether the off-site spaces that Mr. Rossdale mentioned were sites that HHC owns or rents. Mr. Rossdale advised that both spaces are in DOH building that are not leased, but that HHC occupies space in. He noted that this will allow for consolidation of services, and would provide additional space.

Ms. Youssouf requested that the facility have a detailed plan and be sure to look at every possible contingency in order to find and reflect the true cost of the project. She said she would hate to see a project budget increase on another construction project. Mr. Pistone agreed and noted that this new method of presenting construction projects for committee approval is a way of increasing accountability.

Mrs. Bolus asked what the facility plans to do with the "T" building. Mr. Rossdale advised that there have been discussions about Communitlife utilizing the parcel of land to create supportive housing. He noted that a non-binding letter of intent had been provided to the organization to support the idea.

Mrs. Bolus asked if there would be a guarantee that 60% of the proposed supportive housing would be for HHC patients. Mr. Wool said yes.

Ms. Brown explained that for a number of years HHC had been working toward establishing partnerships with organizations that receive financing to develop housing having good reputations with the Department of Housing Preservation and Development (HPD), and the Housing Development Corporation (HDC). Communitlife is such an organization. She advised that Communitlife plans to submit a request for \$60 million in capital funding to construct housing on the site, and in order to assist with that request a letter of intent was issued to them in show of support for the proposed site they had identified. It was assured that a portion of that housing would be expressly used for HHC; first for HHC patients residing in Queens, and then for other HHC patients, whether it be for people being discharged from facilities, the disabled, veterans, families of veterans, etc. There is little subsidized housing in Queens and this should be seen by the surrounding community as being responsive to the Borough's needs.

Ms. Youssouf asked if there is a contingency plan should Communitlife be denied. Ms. Brown said that is unlikely being that they are responding to a Request for Proposals (RFP) and the annex to that RFP identified providers that would get priority. Communitlife was on that list. She added that there is also a timeline which assures that HHC would receive an answer by a certain time and noted that Communitlife is aware that if they do get the project they will need to wait for vacating to take place, which will happen on HHC's schedule.

Ms. Youssouf expressed concern about the capital budget and warned against rushing through the process. Ms. Brown advised that HHC has been clear about the need for intensive review and their need to plan and pace accordingly.

Multi-Service Centers – Occupancy Fee Rate Adjustments

Jeremy Berman, Deputy Counsel, Legal Affairs, advised that the Department of Citywide Administrative Services (DCAS) had recently requested an increase in occupancy fee for three sites occupied by HHC off-site clinics. Mr. Berman identified locations of the sites at Guy Brewer Boulevard in Queens, 120th Street in Upper Manhattan, and Bushwick Avenue in Brooklyn. He explained that while HHC seeks approval for a three or five year term with a static occupancy fee, DCAS issues year to year agreements and although there is generally no increase, this year they are asking for an additional \$3.00 per square foot. He explained that although HHC was only notified regarding one site it was not until the Office of Facilities Development inquired about the other two location that it was determined that increases were being requested at all three sites. It was then determined that this is an issue that must be addressed with the Committee and likely the full Board. Mr. Wilson confirmed that a facility had alerted him that a \$3.00 per square foot increase had been requested at one specific site and it wasn't until he followed up that he discovered that the same would be the case for two other sites.

Ms. Youssouf asked if this increase would be retroactive. Mr. Berman said he did not believe so.

Ms. Youssouf asked whether the new rate had already been imposed. Mr. Berman said no.

Mr. Martin asked what the increase would amount to cumulatively, for all three sites. Mr. Wilson said he would have to compile that information.

Mrs. Bolus asked what types of services are provided at the sites. Mr. Martin advised that the clinic at Guy Brewer Boulevard in South Queens provides geriatrics, obstetrics and gynecology, and pediatrics services, substantial operations. Mrs. Bolus asked if the sites were operated by different hospitals. Mr. Martin said yes, and reiterated that a cumulative increase amount would be needed.

Ms. Youssouf requested a total dollar amount for the cumulative increases, as well as proposed start and end dates for the increase periods. She noted that the Board authorized a lease at the current rate so they need to know what the variance would be. She asked for that information to be brought to the Board. Mr. Pistone said he would be sure that was done.

Mr. Martin asked if Meryl Weinberg, Executive Director, Metropolitan Hospital Center, was aware of the increase being that Metropolitan

Hospital oversees the 120th Street location. Ms. Weinberg said she was familiar with the site, La Clinica del Barrio, which provides primary care services but she was unaware of the increase. She added that although she was unaware the Chief Financial Officer (CFO) may have known.

Mr. Berman advised that the information was received too late to bring the matter to the July Committee meeting.

Mrs. Bolus asked why the real estate tickler system had not warned of the upcoming expiration. Mr. Wilson stated that the tickler system tracked the Board authorization, which was for a three year term, and not the yearly agreements from DCAS. Ms. Youssouf agreed with Mrs. Bolus that the tickler system should have prompted the upcoming expiration.

Dr. Stocker asked how a contract for a certain number of years can be changed in the middle. Mr. Berman said that the actual contracts are yearly agreements but the Board is asked to approve multiple years based on the fact that rates rarely increase. We ask for multi-year approval because there has never been an increase.

Ms. Youssouf said she was concerned and felt this situation was a result of sloppiness. She again asked that at the Board meeting all appropriate info be provided so that the Board knows what they are approving.

Mr. Martin asked if these three sites are the only ones affected. Mr. Wilson said yes.

Ms. Youssouf asked if any other space we occupy would put us in a similar situation. Mr. Berman said no, this is it. Ms. Youssouf said she wanted to be sure of that because she felt like there may be more surprises.

Project Status Reports

Central/North Brooklyn Health Network

Generations+/Northern Manhattan Health Network*

Queens Health Network*

* Network contains project(s) that require a delay report

As advised in the Assistant Vice President's Report there was no significant progress to report on any project in delay.

Old Business:

License Agreement – Sprint Spectrum at Goldwater Campus

Mr. Berman explained that this license agreement was approved by the Committee in November 2012, but was never moved forward for consideration by the full Board because vendex approval had not been issued. Now that vendex approval has been issued the resolution has been included in the current capital package so that it may move forward to the September 27, 2012, meeting of the Board of Directors.

Mrs. Bolus asked how the Greenpoint Clinic project was progressing. Mr. Pistone advised that the Department of Health (DOH) inspection scheduled for July did not take place, it will hopefully occur soon so that progress can begin on the third floor.

Community Relations Committee – September 4, 2012

As reported by Josephine Bolus, RN

Chairperson's Report

Mrs. Bolus opened the meeting with a warm welcome to everyone in attendance. She stated that she "hoped that everyone had enjoyed the summer and looked forward to working with them this fiscal year during what is likely to be a period of new challenges requiring renewed vigor and dedication." Mrs. Bolus proceeded to review some significant developments that had occurred since the last meeting on May 1st.

Mrs. Bolus stated that many Committee members had participated at the annual Marjorie Matthews Awards ceremony and barbecue on the Coler campus of Coler-Goldwater by the East River. She added that, despite record-setting sweltering weather, the occasion had appeared to be fully enjoyed by all. Mrs. Bolus reported that recognition was given to more than forty CAB and Auxiliary leaders for their exemplary community advocacy; and more than two hundred friends and family members had joined the honorees at this event. She noted that the Marjorie Matthews Awards ceremony and barbecue has certainly become a major HHC-wide community and family gathering.

Mrs. Bolus reported that at its June meeting, the HHC Board had passed a resolution naming the new HHC long term care facility being developed in Harlem to replace the current Goldwater campus on Roosevelt Island the Henry J. Carter Specialty Hospital and Nursing Facility, to recognize Mr. Henry "Hank" Carter's longstanding support of the residents and programs at Coler-Goldwater Specialty Hospital and Nursing Facility. She quoted the Board's resolution, "His gifts and donations to Coler-Goldwater over the past 39 years has resulted in a computer lab, personal computers, a rehabilitation gymnasium, assistive and mobility equipment, specially outfitted buses and thousands of state-of-the-art wheelchairs, all of which have provided our residents with greater independence, greater comfort and the opportunity to learn and grow." She added that the value of Hank's generosity to Coler-Goldwater through Wheelchair Charities, the philanthropic organization he created, exceeds \$25 million.

Mrs. Bolus reminded the Committee and invited guests that there was a major national health policy development since the last meeting on May 1st. Mrs. Bolus reported that, on June 28th, the U. S. Supreme Court had issued its long anticipated decision about the constitutionality of the Affordable Care Act (or the ACA); ruling by a 5 to 4 margin that the ACA was constitutional, including the provision that mandates virtually all Americans to purchase health insurance. However, the Court, by a 7 to 2 margin, had narrowed the reach of an important ACA provision that had required states to expand their Medicaid programs or risk losing all of their Medicaid federal funding. As a result, states can now opt not to insure greater numbers of low income citizens through their Medicaid programs.

Mrs. Bolus reported that New York State will expand its program. She added that an estimated 1.2 million New Yorkers are expected to gain health insurance coverage as a result of the ACA, when the law is fully implemented in 2014.

Mrs. Bolus reminded Committee members and invited guests that a new fiscal year, Fiscal Year 2013 began on July 1st. Mrs. Bolus noted that HHC staffs are to be recognized for achieving annual savings of more than \$480 million by the end of Fiscal Year 2012 through implementation of many of the cost containment and restructuring initiatives in the Road Ahead. She added that, these programs have netted HHC more than \$1 billion dollars in savings over the last three years. In addition, in Fiscal Year 2013, another \$294 million in savings are projected to be accomplished through other gap-closing activities. Mrs. Bolus noted that, unfortunately given the very real and significant financial challenges that HHC faces, these gap closing initiatives have included changes in the way the facilities assure that patients have access to the services they need. She added that specifically, in July, the Board had approved a contract to outsource the provision of dialysis services.

Mrs. Bolus reported that New York State had submitted a proposal to the federal Center for Medicare and Medicaid Services (CMS). She added that a total of \$10 billion in funding is proposed for over five years, essentially to support the action plan of the State Medicaid Redesign Team (MRT). Mrs. Bolus stated that strong support is being expressed in particular for the "Public Hospital Innovation" section of the MRT Reinvestment Program, under which HHC would obtain at least \$1.15 billion. Mrs. Bolus noted that this would go a long way toward reducing the shortfall that HHC faces over the next several years so that the facilities can continue their efforts in care management, reducing readmissions and improving access to primary care.

Mrs. Bolus stated that it is important for all to be aware of the achievements of HHC of advancing patient safety and supporting patient advocacy in all of the facilities. She added that one of the ways in which this is achieved is through the use of technology - with system-wide electronic medical records. In this vein, Mrs. Bolus reported that all HHC facilities have now been qualified as a "meaningful user" of electronic medical records and would begin receiving nearly \$200 million of federal American Recovery and Reinvestment Act (ARRA) funds. She added that these funds would help HHC with the implementation of the next generation of electronic medical record system.

Mrs. Bolus announced that this year's Annual CABs Council Conference is scheduled for Wednesday, October 24th and the focus would be "Training for Patient Advocacy". She noted that the Conference's key note speaker will be Ms. Patti Skolnik, a nationally recognized patient advocacy organizer and trainer.

Mrs. Bolus announced the Fiscal Year 2013 Annual Public Meetings dates and locations. She highlighted that the first one will take place before the next meeting on Wednesday, November 7th at Coney Island Hospital beginning at 6:00 p.m. She added that the Bronx will be Monday, November 19th at Jacobi Medical Center; Queens will be Monday, December 3rd at Queens Hospital Center; Staten Island will be Wednesday, December 5th at the Sea View Rehabilitation Center and Home and Manhattan will be Wednesday, December 12th at Bellevue Hospital Center.

Mrs. Bolus stated that, "an important election is just around the corner. She noted over the next two months, community outreach for voter education and assistance concerning registration and voting is being mobilized by each facility's CAB and Auxiliary, along with the labor partners." She stressed that the last day for voter registration for the General Election is October 12th.

Mrs. Bolus concluded her report by recognizing some recent achievements:

- Lincoln Medical and Mental Health Center received the prestigious American Hospital Association's Quest for Quality Award. She noted that Lincoln was one of four hospitals selected this year from a nation-wide pool of 40 hospitals.
- Both Jacobi Medical Center and Woodhull Medical and Mental Health Center were ranked among the best hospitals in New York by U.S. News and World Report; they were listed in the top 50 among 730 hospitals nationwide as high performers in one or more specialties.

Mrs. Bolus noted that these are well deserved achievements and reflect the hard work and dedication of the employees at three HHC hospitals.

Mrs. Bolus turned the meeting over to President Aviles for his report.

President Remarks

Mr. Alan Aviles, President, greeted Committee members and invited guests hoping that they all had a great summer. Mr. Aviles began his remarks stating that he would expand on two items referenced in Mrs. Bolus' report. Mr. Aviles reported that the Corporation had just completed the second of four year of its comprehensive cost containment and restructuring plan. He announced that over the last three years

the Corporation had saved more than \$1 billion dollars through its cost containment restructuring initiatives. He emphasized that, in order for HHC to hit the set target of saving at least \$300 million annually for the remaining two fiscal years of the plan and gain some fiscal stability, the Board of Directors had approved last July HHC's most challenging initiative to contract with an outside vendor to provide dialysis services.

Mr. Aviles stated "that dialysis services are currently outsourced at Bellevue Hospital Center and significantly at Elmhurst Hospital Center for the last six years by the same vendor approved by the Board of Directors last July to contract with HHC for dialysis services." Mr. Aviles rated the vendor's quality of work as excellent. He stressed that no patient, whether uninsured or undocumented, has ever been turned away and that it is made clear in the Board Resolution and the signed contract that there is an absolute iron clad guarantee that these patients would not be denied dialysis services. Mr. Aviles noted that there is no impact on access to services, as the vendor over the course of the next three years must provide capital dollars to expand services in some areas. As such, there will be expanded onsite services at Lincoln Hospital and, for the first time, a dialysis unit filled at North Central Bronx Hospital. In addition, dialysis capacity in some of the other sites would be expanded slightly as well. Mr. Aviles reported that overall, when the plan is fully implemented at the end of the next three years, there will be 35% more capacity for dialysis and HHC will net more than \$150 million in savings. Mr. Aviles stressed that the plan is expected to go forward with no layoffs and that existing dialysis staff are being redeployed throughout the Corporation where there are needed.

Mr. Aviles expanded on another item in Mrs. Bolus' report known as the 1115 waiver. He explained that, just as Governor Cuomo is doing in New York State, the other states are also reforming the Medicaid Program to save money and to better serve patients. He added that since Medicaid is a program financed 50/50 by the State and the federal government in New York, the federal government would be entitled to half of any savings. As such, the States ask the federal government to reinvest a good portion of the projected savings to help accelerate the reforms that they are trying to implement in the waiver. Mr. Aviles stated that the Medicaid Redesign Program in New York would save the federal government over \$17 billion over five years. He informed Committee members and invited guests that an application is being sent to the federal government asking that \$10 billion of the estimated \$17 billion to be reinvested into New York State over a five year period (roughly, \$2 billion a year) to expand primary care capacity, provide more support for electronic medical records, improve care coordination in some areas and (for the first time) to also provide for supported housing. Mr. Aviles noted that approximately \$1 billion in the waiver is for supported housing over the course of five years. He added that other dollars are targeted for safety net voluntary hospitals to sustain them and to help them reorganize or merge.

Mr. Aviles reported that the amount of money asked for public hospitals is \$1.5 billion; \$1.2 billion of which is targeted to HHC to help expand its primary care capacity, allow for care management and care coordination, particularly for the undocumented. Mr. Aviles added that HHC is expected to receive some other State monies to cover some of the cost of these services for Medicaid insured individuals; however, since HHC's mission is to provide the same level of care to all patients, whether insured or uninsured, these funds would be used for the non-Medicaid patients.

Mr. Aviles noted that while inpatient emergency care is covered, the outpatient care that might prevent that emergency admission is not covered. He added that in an attempt to have targeted dollars to support for outpatient care services, the 1115 waiver is a noble approach to have the federal government pay for pre-emergency care services. Mr. Aviles stated that there is no guarantee that the 1115 Waiver will be approved or, that HHC will get all the funds as allocated by the State, if approved; however HHC is appreciative of the proposed amount requested for public hospitals. Mr. Aviles acknowledged LaRay Brown, Senior Vice President, Community Health and Intergovernmental Relations, who has worked tirelessly to ensure that the public hospitals have a fair share.

Mr. Aviles reported that under the Medicare program, HHC had filed earlier this week an application with the Centers for Medicare and Medicaid Services (CMS) to become an Accountable Care Organization (ACO). He stated that, ACO is a reform included in the federal Affordable Care Act (ACA) and is an effort to begin to transform the way healthcare is delivered. He explained that providers and healthcare systems would no longer be paid based on the volume of Medicare patients, but rather to keep as many patients as possible healthier through a combination of robust primary care and preventive care, better care coordination, and more effective care management. Mr. Aviles added that, if providers and healthcare systems keep their Medicare patients healthier than they otherwise would have been; and as a result, their future healthcare costs over the next year or two are lower than what they were over the last couple of years, then, they are entitled to share the difference of those savings. In addition, Mr. Aviles stated that any shared saving HHC would receive from the Medicare Shared Savings program would be evenly split with the physicians who care for these patients after deducting the basic cost for running an Accountable Care Organization. Mr. Aviles stated that, based on ACO models across the country, it takes about two to three years before any savings can be achieved; therefore, it is unlikely that HHC would accumulate any savings by next year. However, Mr. Aviles stressed that the Medicare Shared Savings program is a positive development and that in many ways HHC leadership has been focused on trying to reduce unnecessary emergency department visits and avoid readmissions. Mr. Aviles thanked Ms. Jeromane Berger-Gaskin, cross-representative CAB member for Kings County Hospital Center and Dr. Susan Smith McKinney, for agreeing to be HHC's Medicare beneficiary on the Board to share her Medicare patients' prospective to the governing body. He also thanked Ross Wilson, MD for leading a team of senior people in the program.

Finally, Mr. Aviles reiterated the importance of the upcoming election. He joined Mrs. Bolus in emphasizing the need to try and encourage everyone to get out and vote on Election Day. He added that the stakes for healthcare and for public hospitals, and particularly for HHC, are extremely high. He added that with the selection of Paul Ryan as the Republican presidential candidate, voters will have to make an informed decision. He stated that the choice is about the current Medicare program which guarantees benefits to seniors vs. a voucher program that would essentially transfer a lot of those costs to seniors. Mr. Aviles explained that, under the voucher program, as healthcare costs increases, these costs are basically shifted to the back of the seniors who will be paying the difference after receiving their premium voucher to try and buy

health insurance policies. Mr. Aviles noted that this program would make a huge difference with enormous implications going forward even if it would not take effect for a while.

Mr. Aviles stated that another big issue is Medicaid, specifically the block granting of Medicaid proposed by the Republicans. He explained that, Medicaid is an entitlement program, granted to a number of people in the state who meet the eligibility requirements. He noted that during the economic downturn, a lot of people have been out of work and the enrollments have swelled during this period of high unemployment. He noted that since Medicaid is a shared program between states and the federal government, as the need for Medicaid grows in the states, the federal government spends more. On the other hand, Mr. Aviles explained that the amount the federal government spends on Medicaid would be capped and does not increase enough to keep up with health care inflation if more people become unemployed and need Medicaid under the block grant proposal. Mr. Aviles noted that federal funding for Medicaid would not grow when more people need health services, particularly during the time of the economic downturn, and the States would have to pick up the difference if they want to run a Medicaid program without cutting benefits and eligibility requirements. Mr. Aviles reiterated that it is another very distinct choice that voters will have to make in the upcoming election and is hopeful that they will make the right choice.

Mr. Aviles ended his remarks stating that repealing the Affordable Care Act would be making a huge step in the opposite direction of where healthcare has been heading, which is gradually to get closer to universal coverage.

Mr. Bobby Lee, Bellevue Hospital Center's CAB Chairperson, reiterated the importance for Committee members, CAB members and invited guests to vote and to also encourage their friends, families and neighbors in other states to vote.

Ms. Agnes Abraham, Chairperson of the Council of CABS and Kings County Hospital Center's CAB referred to Mr. Aviles report on the State of New York's application to reinvest \$10 billion into New York State and asked a two-fold question. She would like to know if a date has already been set for the release of the \$1.2 billion targeted to HHC and if there is a plan in place about the distribution of these funds across all the facilities.

Mr. Aviles answered that the funds would be distributed at least over a five-year period which may stretch to six to seven years. He argued that if the full amount of approximately \$200 million yearly is awarded, it would likely start some time during this next federal fiscal year to begin on October 1, 2012. He added that the disbursement date depends on how quickly they act upon approving the application. He stated that the effort is to get it approved before the election. Mr. Aviles stated that these funds are designated for initiatives across all the facilities and could begin to flow about the same time to all of the facilities as early as the beginning of next year. He informed the Committee that more details will follow about how specifically these funds will be used to expand primary care access in each of the Networks and each facility. Mr. Aviles commented that if the funds are awarded, all the facilities would significantly benefit from these funds in the very first year.

Ms. Abraham explained her concerns about the disbursement of the funds to HHC. She reasoned that because so many hospitals are closing, HHC hospitals and Kings County Hospital, in particular, are overcrowded. She stated that HHC needs to be able to continue to provide the kind of care that it is notoriously known for at Kings County Hospital.

Ms. Abraham queried Mr. Aviles about the dialysis employees and wanted to know if all managerial, clinical and cleaning staff will remain HHC employees or transferred over to the Vendor.

Mr. Aviles answered that most of the staff with the exception of clinical leadership would become the vendor's staff. He explained that, in order to have direct control over quality and retain clinical oversight, one of HHC's Nephrologist and Clinical Care Specialist would be the Medical Director of that unit. However, those employees who do not want to be transferred over to the vendor would be redeployed to other clinical physicians within the system.

Ms. Abraham asked if the employee who elects to remain employed with HHC but whose skills cannot be easily matched to be redeployed within HHC would be forced to retire or get a pink slip.

Mr. Aviles answered that while these employees may have worked in the dialysis unit, their skills are transferable to other units. In addition, the Corporation would arrange to provide for additional training, if necessary, to help them make the transition to another care setting. Based on the Elmhurst Hospital's experience, Mr. Aviles asserted that the transition would happen very smoothly and that all the employees would be placed.

Ms. Abraham's last question was about ACO's Medicare Savings Plan. She would like to know how savings are calculated and what metrics would be used to measure them.

Mr. Aviles answered that, part of the Shared Savings Program is a set of 33 quality indicators or metrics that are intended to ensure the quality of care based upon outcomes data can actually be monitored so that the patient will disqualify himself from getting any shared savings, or at least it will adversely affect the amount of shared savings the patient gets if he does not perform at certain pretty high levels on the quality performance indicators.

Ms. Gladys Dixon, Coler/Goldwater and Specialty Hospital and Nursing Facility (Coler campus) CAB Chairperson asked about the vacancies that would be created by the facility's nursing and managerial staff after the move to move of Goldwater to Harlem.

Mr. Aviles answered that HHC still have a significant attrition target to hit over the course of the next two years. He informed the Committee that the workforce has already been reduced by approximately 2900 employees over the course of the last three years and that number is targeted to increase to 3750 by the end of Fiscal Year 2014. He added that the ideal thing would be not to backfill positions that occur elsewhere and redeploy staff to those vacant positions, thereby avoiding layoffs and effectively reduce the headcount overtime. Mr. Aviles stated that whether or not that works perfectly depends on the type of vacancies and the skills of the individuals to be redeployed. He emphasized that HHC's general approach has always been to bring the headcount down and reduce the workforce without having to compel layoffs. He affirmed to the extent that approach is possible for everybody who works at Coler/Goldwater, leadership will try to do so. Mr. Aviles added that, invariably in similar situations, there will be a number of staff eligible for retirement who had elected not to retire at this point, but who will elect to retire rather than make a change within the system; and that may help as well. However, Mr. Aviles noted that it will be challenging because a significant decrease in the number of beds is at stakes.

North Bronx Healthcare Network

Jacobi Medical Center (Jacobi) Community Advisory Board

Mrs. Bolus introduced Ms. Cheryl Alleyne of the Jacobi Medical Center CAB and invited her to present the CAB's annual report on behalf of the Ms. Sylvia Lask, Chairperson.

Ms. Alleyne reported that this was another exciting year for the Jacobi Medical Center Community Advisory Board. She stated that in addition to annual CAB sponsored 911 Memorial Event and the Legislative Forum, the CAB added a new public Conference on Mental Health which was held in May in recognition of National Mental Health Month. She noted that this year's topic was "Trauma's Impact on Mental and Physical Health," which was well attended.

Ms. Alleyne informed members of the Committee and invited guests that based on the success of the conference; the Jacobi CAB plans to sponsor another conference in May 2013 focusing on the topic of individuals with mental health issues and housing.

Ms. Alleyne stated that Jacobi Medical Center's LEAN initiative, is an ongoing improvement program, it has been very successful in helping to make Jacobi's services more efficient, effective and safe. She continued and noted that in addition, the North Bronx Health Network is in the process of a hospital-wide Center of Excellence initiative that aims to embrace new standards for the delivery of services.

Ms. Alleyne continued and reported that the most significant health issues in the community include obesity, diabetes and hypertension. She added that the Bronx is also at the center of the HIV/AIDS epidemic.

Ms. Alleyne informed the Committee members and invited guests that Mr. Walsh, Senior Vice President of the North Bronx Healthcare Network and his staff provide the CAB a review of the hospital fiscal issues, new programs and initiatives.

Ms. Alleyne reported that the Jacobi CAB supports the development of a weekly Farmers Market that brings healthy and nutritional, fruits and vegetables, to the hospital for patients, staff and the community. She noted that the Farmers' Market operates from June through November.

Ms. Alleyne concluded the Jacobi CAB report by stating that "Jacobi Medical Center offers unique services and programs; the staff is knowledgeable and compassionate, the community is proud of the hospital."

North Central Bronx Hospital (NCB) Community Advisory Board

Mrs. Bolus introduced Ms. Esme Sattaur-Low, Chairperson of North Central Bronx Hospital and invited her to present the CAB's annual report.

Ms. Lowe began the NCB CAB's annual report by announcing that NCB has provided quality care and serving generations of families in the Norwood Community for over thirty-five (35) years.

Ms. Lowe reported that NCB's Executive and Clinical Leadership participate in their monthly CAB meetings and keep CAB members informed of new healthcare and operational initiatives, the scope and development of hospital services and HHC's collaborative programs. She noted that the information received enables the CAB members to stay fully informed and allow them to share important information with the community.

Ms. Lowe stated that NCBH CAB members are always on hand to support the hospital's outreach activities by attending ribbon-cuttings ceremonies, health fairs and helping with the distribution of flyers in the community. She added that the NCB and Jacobi CAB jointly sponsored a Mental Health Conference that focused on trauma, and a Social Work Conference that focused on the Emergency Response in the Community. She noted that both events were well attended by community residents.

Ms. Lowe continued and reported that the most significant health issues in the community include obesity, diabetes, and hypertension. Ms. Lowe stated that "more recently, special care for geriatric patients with psychiatric disorders has become a pressing concern in the community."

Ms. Lowe added in order to address the health issues and concerns of the community; the leadership of NCB has initiated extensive outreach by informing residents and local merchants of the various services and programs NCB offers.

Ms. Lowe concluded the NCB CAB report by acknowledging Mr. Walsh, the Senior Vice President of the North Bronx Healthcare Network who always provides a comprehensive review of issues and concerns as well as information about new programs and initiatives in his monthly reports to the CAB. She added that the CAB also receives presentations from the various department heads and which time the CAB members have had an opportunity to ask questions and learn more about the hospital's economic challenges. Ms. Lowe stated the "NCB CAB is proud of the hospital and the community and will continue to work to make both stronger."

Queens Health Network

Elmhurst Hospital Center (Elmhurst) Community Advisory Board

Mrs. Bolus introduced Carlos Cortes, Chairperson of Elmhurst Hospital Center and invited him to present the CAB's annual report.

Mr. Cortes began his presentation by greeting members of the Committee and acknowledging the outstanding leadership team of Elmhurst Hospital Center. Mr. Cortes noted that Ann Sullivan, M.D., Sr. Vice President, Queens Health Network, Chris Constantino, Executive Director, Jasmin Moshirpur, M.D., Medical Director and Joann Gull, R.N., Nursing Director are supportive and has built a relationship with the Elmhurst CAB based on respect and trust.

Mr. Cortes reported that Elmhurst Hospital Center is facing challenging times with increased workloads, decreasing revenues, new health reforms, and changing Medicaid and Medicare reimbursements. Mr. Cortes added that the CAB is concerned that this will put a strain on staff as well as HHC. He noted that the Elmhurst CAB is confident that the hospital's leadership will continue to provide access to quality health care for the community.

Mr. Cortes paused for a moment to extend a special thank you to Mr. Aviles who attended the Elmhurst's CAB meeting earlier this year. Mr. Cortes stated " members of the CAB was impressed with Mr. Aviles' commitment to our public mission and his dedicated leadership in keeping HHC at the fore front of health care in these critical times. "

Mr. Cortes continued and reported that the Elmhurst CAB had a busy year. He noted that at each general CAB meeting guest speakers provide the CAB with information about the hospital's programs and special initiatives. Mr. Cortes highlighted some of this year's presentations: Libertas Program that provides services to survivors of torture, the Sexual Assault Response Team; he noted that Elmhurst Hospital is a Center of Excellence with Sexual Assault Forensic Examiners.

Mr. Cortes reported that the Elmhurst CAB's Legislative Committee led a successful Legislative Luncheon in February. He also noted that the CAB's Women's Health Committee with the hospital's Joint Labor/Management Committee held its annual Women's Health Forum in May. He added that both events were well attended by the community.

Mr. Cortes concluded his report by acknowledging the dedication and commitment of staff during last year's Hurricane Irene. Mr. Cortes stated that "the employees volunteered to help staff the medical shelters that were set-up in response to the evacuations of various nursing homes in the area.

Queens Hospital Center (Queens) Community Advisory Board

Mrs. Bolus introduced Anthony Andrews, Queens Hospital Center CAB Chairperson and invited him to present the CAB's annual report.

Mr. Andrews began his presentation with a warm welcome to the Committee members, CAB's Chairpersons and invited guests.

Mr. Andrews informed members of the Committee and invited guests that at Queens Hospital Center the most pressing concern are to ensure that hospital can effectively continue to serve the influx of patients it has seen since the closure of local hospitals which has caused the Emergency Room to be over capacity on many occasions. Mr. Andrews added that this situation is primarily due to the closures of several local hospitals' catchment area and as a result, the Emergency Department has often been extended beyond its capacity.

Mr. Andrews concluded his report by commending Julius Wool, Executive Director who has been extremely supportive in all the CAB's endeavors. He noted that Mr. Wool has developed an excellent curriculum for the orientation and training of new CAB members.

Finance Committee – September 11, 2012 **As reported by Mr. Bernard Rosen**

Senior Vice President's Report

Ms. Marlene Zurack informed the Committee that she had four items to report, a FICA refund, status of cash on hand (COH), a Soarian update and a retirement announcement. Ms. Zurack began with the announcement of Carol Ungar's retirement. Ms. Ungar retired after thirty six years at HHC working in Corporate Revenue Management where she managed all of the collection agency contracts for the Corporation. Ms. Ungar has worked very closely with many of the consumer advocates on resolving some very difficult issues in managing and overseeing those agencies to ensure that HHC patients were treated fairly. Congratulations to Carol on her retirement.

Ms. Zurack stated that HHC is coming upon its 3rd phase of the Soarian implementation. The Revenue Management Information System was presented to the Board in 2007. Since that time, two functions, Document Imaging and the Decision Support were implemented. Currently, HHC has reached the core of its implementation which is the scheduling and on September 24, 2012 the first facility that will "go live" with this function will be Coney Island. The implementation of that function will activate the enterprise-wide data base which in essence will establish a way of centralizing appointments scheduling throughout the Corporation, whereby there will be only one master index for all of the patients at HHC. This is only Phase I of the scheduling function that represents only a piece of the implementation. Therefore, September 24, 2012 is a very important milestone for HHC in terms of this project. The first set of sites to undergo the implementation includes Bellevue, Gouverneur and Metropolitan and by January 2013 – March 2013 the remaining facilities will be implemented. The next major function that will come several months after the completion of the scheduling phase will be the financial function. If the Committee member would like a more in-depth briefing, Ms. Katz will present a status report at the November 2012 Information Technology Committee in November 2012.

Dr. Michael Stocker, Chairman of the Board, asked how long would HHC continue with the dual number system given that in order to have a centralized appointment system there must be a number that would be common to all patients across the system.

Ms. Maxine Katz stated that as part of the initial implementation of Soarian there will be a corporate patient identifier for each patient which has been done off-line for more than a year but will now be taken over by Soarian. The structure has been established whereby a single number can be used in its entirety. However, for now each facility's local medical record number will remain. Additionally, in the Soarian master patient index, the individual needs along with the patient identifier, and each site that the patient has been with their local medical record number will be maintained. Eventually HHC will be able to go to a single medical record number but locally the facilities will continue to use the local medical record number.

Dr. Stocker asked if a patient from Coney Island hospital goes to Bellevue would that patient get a corporate patient identifier or both.

Ms. Katz stated that at this stage the patient would get both given that converting to a single number would be major undertaking but within the Soarian system, HHC will have the capability to go to a single number as determined by HHC.

Ms. Zurack added that it would require a more extensive discussion than just the revenue cycle system and would involve mostly IT given that it relates to the medical record component.

Dr. Stocker asked if the system would be integrated with the new electronic medical record (EMR). Ms. Katz stated that it would be and that discussions with Dr. Louis Capponi, Chief Medical Informatics Officer, on this issue have been extensive in order to ensure that the requirements for the integration are in place in Soarian in anticipation of the EMR.

Dr. Stocker added that some of the facilities have integrated their appointment system locally such as Woodhull Hospital.

Ms. Katz stated that some of the facilities have a centralized call center but there are separate data bases within Siemens. There is only one data base from an appointment scheduling perspective. Although within some networks, that system has been implemented, such as Woodhull and Cumberland; Harlem and Renaissance but from an appointment scheduling, the appointments are being booked into separate data bases.

Dr. Stocker stated that appointments scheduling is very local in some of the clinics that include all of the variations tailored to their requirement needs.

Ms. Zurack stated that the templates are being standardized corporate-wide as part of the installation.

Dr. Stocker asked if there are agreements by the facilities in support of that action. Ms. Zurack stated that the facilities have agreed as part of a value stream (VS) that was undertaken by Ms. Katz as part of Breakthrough to standardize the templates, whereby there were several improvements that took place as part of that process. The clinical staff and a number of others including Dr. Wilson, Senior Vice President, and Chief Medical Officer were involved.

Dr. Stocker asked if any issues are anticipated from the physicians regarding the scheduling system. Ms. Katz stated that agreements were obtained from all of the ambulatory care staff on the appointment types; type of booking activity; standardized activity across the corporation; standardized numbering corporate-wide. Through these efforts, the Corporation was able to obtain consensus. There is some flexibility in the length of the appointment but standard within the template.

Ms. Emily Youssef asked if the patient would be assigned two numbers.

Ms. Zurack stated that the baseline for understanding this implementation is that currently patients have different medical record numbers at some of the facilities. HHC patients will have a different medical record number for each facility with the exception of those networks that have

worked to create a single medical record number. Some patients may have multiple medical record numbers in the same hospital based on the information provided by the patient. There are numerous medical record numbers for HHC's 1.3 million patients which make the goal of going to a single number more difficult. This is only step one of a multiple phase project. Each patient will be given a number and all of the medical record numbers will be linked to that number. In order to go to a single number, all of the data bases would need to be unified on the medical record side, which at this stage HHC is not prepared to do at this time. The feedback from the Committee is very helpful in assisting HHC in this implementation process. Currently in order for a patient to make an appointment, the patient must be in that hospital's current system and to make an appointment at another facility it would require logging in and out to that different hospital. This process will be eliminated with this implementation phase. This is a major change for HHC. HHC's IT systems are basically set-up as though HHC is functioning as separate organizations and with this phase of Soarian, HHC would be phasing into one organization with data and to migrate is a major task. The purpose of this update was to keep the Committee informed of the implementation as HHC moves forward. As previously mentioned, there will be a more detailed discussion in November 2012 at the IT Committee which will be after the September 24, 2012 implementation at Coney Island. Additionally, at that point, HHC will have an early read on the progress of the initial "go-live" implementation.

Mr. Rosen asked if the milestone for HHC is the upcoming implementation at Coney Island and whether by November 2012, all patients will get a new number.

Ms. Zurack stated that patients will get a patient identifier number which will be linked to the existing multiple medical record numbers.

Mrs. Bolus asked if the patient would be given a card with both numbers. Ms. Katz stated that each facility has its own system in terms of the issuance of the cards. However, from a corporate perspective, that would be another project that will be addressed in the future. Currently within Soarian the capability from a technology perspective to address that issue exists.

Ms. Zurack added that the issuance of a card was not in the initial work plan and would be expensive to do at this time; however, with the implementation of this phase, HHC will have the capability to do if and when it is decided.

Ms. Katz added that it would be more realistic to wait until after the implementation of the EMR so that the process if fully implemented, integrated and in-sync with that system. Also it is important to ensure that HHC does not implement things that might require changes in the future that could be costly. There are other things such as kiosks, portals, and biometrics that have also been discussed with clinical IT and concluded that having the structure in place is essential in order to allow HHC to do those things in the future.

Ms. Youssouf asked if it is based on the EMR system or multiples. Ms. Katz stated that the structure that is currently being developed in Soarian is not based on the implementation of any particular EMR system. It is the business need and how HHC will proceed and how an EMR would work at HHC.

Mr. Rosen asked what will happen after Coney Island hospital goes "live" and a patient is entered into the system. Ms. Katz stated that based on a name or demographic search in Soarian, it would show the facilities that the patient has gone. However, due to Health Insurance Portability and Accountability Act (HIPAA) requirements, if it is not the local site for that patient, the actual medical record number will not be displayed as part of the protective information.

Dr. Stocker asked if there is an edit check to ensure the true identity of a patient based on the information in the data base.

Ms. Katz stated that there are weighted algorithms based on a certain weight if there is a social security number, date of birth, weight, age, gender, and other factors that will determine the identity of the patient.

Ms. Andrea Cohen asked if the standardized template included new policies relative to appointment scheduling as part of the process or whether that would be determined after the implementation.

Ms. Katz stated that there have been standard work regarding the appointment links; on the activities types and the definition of those types of activities but not the clinical practices. However, there is flexibility in terms of adjusting the time required by the physician.

Ms. Zurack stated that it is an enabler not the operational decision of the system. Currently the templates are being customized and there are a number of variations; however, with this system that will be eliminated. However, the way in which the templates are used to actually make appointment decisions is not standardized.

Ms. Youssouf asked if the Committee could get a status report on the outcome of the implementation at Coney Island.

Ms. Zurack stated that an update could be done; however, for Finance the major milestone is the September 24, 2012. Moving to the next item of her report, Ms. Zurack stated that in terms of the COH, HHC ended the FY 12 with \$460 million or 32 days of COH. As of the end of August 2012, the COH was \$302 million or 19 days. Currently the projection for year-end is \$140 million and less than 10 days of COH.

Mr. Rosen asked if the year-end reference was June 30, 2013. Ms. Zurack stated that it is the FY 13 ending on June 30, 2013 and that given the severity of this issue, going forward it will require very close monitoring of vendor payments timeframes; and other cash payment issues. In February 2013, a major problem is anticipated that HHC has discussed with the City in terms of rescheduling payments to the City.

Mr. Rosen asked for clarification of the anticipated problem. Ms. Zurack stated that the projection is that HHC will go negative in February 2013, as included on the first draft of the cash flow. To address this issue, HHC is working on rescheduling City payments to the end of the fiscal year. The last item relates to an IRS refund for FICA payments. The IRS determined in April 2005 that some residents at hospitals should not have paid FICA and that the employers should not have been charged as well. There was an opportunity to recoup retroactive FICA contributions from 1997-2005 which has resulted in an approval from the IRS for HHC to receive in either October or November 2012, \$95 million including interest, of which \$36 million will go to the residents and \$58 million to HHC.

Mr. Rosen asked if the action was brought by HHC. Ms. Zurack stated that HHC joined the action as opposed filling an action.

Ms. Youssouf asked if the \$58 million would offset the projected reduction in the COH. Ms. Zurack stated that it would not since it is already included in the cash flow. The report was concluded.

Mr. Rosen informed the Committee that the reporting by Mr. Covino and Ms. Katz as part of the information items would related to the FY 12 year end status.

Key Indicators Report

Mr. Fred Covino reported that as per the Key Indicators as of June 30, 2012, utilization was down by 4.2% in inpatient discharges. A state-wide data search using SPARC to determine how HHC compared to other hospitals in the state and based on that database, HHC is very consistent with the state-wide average; however, HHC was slightly better than some of the other hospitals. Overall, HHC's decline in discharges is fairly consistent across the state. Last year, a review of data compiled by the United Hospital Fund (UHF) was used but it was not available this year. The diagnostic and treatment centers (D&TC) were down by 5.4% in visits and nursing home days were down by 7.1% due to the transition underway at Coler/Goldwater Specialty Hospital & Nursing Facility. The average length of stay (ALOS) with the exception of Lincoln and Coney Island the remaining hospitals were within a 1/3 day of the corporate average. Coney Island was 4/10 greater and Lincoln was 1/2 day less. The CMI at year end was up by .2% from last year. The CMI was up by 6% last year and 4.5% the year before. Therefore, there has been significant improvement in this area that has been maintained in the last several years. FTEs were down by 508 but 92 FTEs short of the 600 FTE target. In terms of the Networks year-end performance, the North Bronx ended the year with a \$50 million surplus which is the 3rd consecutive year with an over \$30 million surplus. Generations +/Northern Manhattan Network ended the year with a \$3 million surplus and has maintained a budget surplus for six consecutive years; South Manhattan ended with a \$75 million deficit primarily due to the transitioning at Coler/Goldwater. However, Gouverneur ended the year with a surplus for the 4th consecutive year and Metropolitan improved significantly throughout the year.

Ms. Youssouf asked what the surpluses were attributable to. Mr. Covino stated that it is due in part to two major factors, one being the rollover of prior year surpluses and the Networks ability to maintain a steady flow in its revenues and expenses.

Ms. Zurack stated that it was important to note that those surpluses are only against budget as opposed to cash on the books.

Mr. Rosen added that it is a comparison to the budget. Ms. Zurack stated that a decision was made by the Corporation several years ago to allow facilities to carryover any surpluses earned in the prior year as a result of generating additional revenues into the next FY that if maintained becomes a cumulative surplus.

Ms. Youssouf asked if there is a time period for those cumulative surpluses. Ms. Zurack stated that there would be if there are major changes, whereby the surplus is used up as opposed to sustaining the current level or improving it.

Dr. Stocker asked how operating surpluses are distinguished from capital expenditures and whether facilities are allowed to use those surpluses for capital projects.

Ms. Zurack stated that they are distinctively separate and facilities have not been allowed to use operating surpluses given the impact it would have on HHC's cash flow. There is money in HHC's capital account that is restricted for capital and there is cash included which is restricted and cannot be used for operating expenses.

Mr. Covino continuing with the reporting, stated that the Central Brooklyn Network ended the year with a \$2.6 million deficit which is a major improvement compared to last year. Kings County had a \$40 million surplus compared to a \$39 million loss last year. Prior to last year Kings County had a significant number of take backs compared to last year which is a very dramatic change. These changes are primarily due to rate adjustments that can be either upward or downward by the State. The Southern Brooklyn/Staten Island Network had a \$27 million surplus for the 4th consecutive year. Queens Network ended with a \$5 million surplus compared to last year. The Corporation ended the year with a \$9.5 million surplus, receipts were \$46 million less than budgeted and disbursements were under budget by \$55.5 million. The actual receipts and disbursements compared to the prior year for the year-end, receipts were \$42 million worse than the prior year primarily due to a decline in workload and a 2% Medicaid rate reduction. Expenses were \$245 million worse than the prior year of which \$95 million was due to fringe benefits, of that amount, \$90 million was related to pension increases and \$78 million was due to an increase in City payments due to timing, and a full year a quarter of malpractice payments compared to three quarters in the prior year. OTPS payments increased by \$73 million due to \$30 million for environmental contracts and laundry services that will be a part of the OTPS payment stream, and \$20 million in fixed assets and \$10 million for nurse registry.

Ms. Cohen questioned the reduction in the D&TCs compared to the hospitals. Mr. Covino stated that it was just a trend.

Dr. Stocker asked if there is any SPARC data available for outpatient services. Ms. Zurack stated that the data is not available.

Ms. Cohen asked if the D&TCs were the same as the hospitals outpatient services and the portion of visits for the hospital outpatient to the D&TCs. Ms. Zurack stated that it is approximately 4 to 1 excluding the emergency department.

Mr. Covino stated that page 4 of the report, actual versus the budget as of the FY 12 year-end, receipts were down by \$46.5 million due to the continual decline in Medicaid fee-for-service which had a significant decline in workload and 2% rate reduction. Outpatient receipts were up by \$46.5 million due to Medicaid managed care whereby there was \$27 million retroactive rate increase from MetroPlus and the ER and Amb Surg rates and a significant increase in the risk pools.

Ms. Youssouf questioned the variance in the appeals & settlements whereby the budget was \$59 million compared the actual receipt of \$10 million. Mr. Covino stated that it was due to three major appeals that were delayed by the State for payment. The revised APG rate that was budgeted at \$30 million; \$9 million for psych methodology; an adjustment of \$22 million and a chronic rehab rate of \$14 million which totaled \$72 million for FY 12 but will be received in the current FY 13.

Ms. Youssouf added that if the estimate had been adjusted, the receipts against that budget would have been even. Mr. Covino stated that it would have impacted the bottom-line revenue had that adjustment been made. In conclusion, expenses were \$7 million over budget due to overtime spending of \$4.5 million. OTPS expenses were significantly under budget primarily due to under spending in IT.

Information Items:

QUARTERLY PS KEY INDICATORS REPORT

Mr. Covino reported that expenses were \$7.2 million over budget. However, expenses have decreased due to a reduction in FTEs of 2,800 over the past two years which translates to annual savings of approximately \$166 million and \$245.8 million including fringes. It is important to understand from a baseline perspective, the impact of the FTE reduction on other expense categories such as overtime, nurse registry and allowances in terms of realigning expenses in order to meet staffing requirements and healthcare needs. As previously stated, of the \$7.2 million overage, \$4.5 million is attributable to overtime spending and a shortfall of 92 FTE in the target.

Ms. Youssouf questioned the variations amongst the facilities in that some were significantly over/under budget and asked what it was attributable to.

Mr. Covino stated that some of the facilities have done well in achieving its FTE target and kept spending in overtime and nurse registry to a minimum. Lincoln for instance had increased overtime expense and failed to achieve its FTE target. The two key components of the positive or negative variance are due largely to those two noted factors.

Ms. Youssouf questioned the significant variance at Coler. Ms. Zurack stated that there are some major capital projects at Coler.

Ms. Youssouf asked if that was included in the cost of the capital project or reflected in the budget as an anticipated expense.

Ms. Zurack stated that it is not included in the capital project given that it is an expense. There is a new operating procedure (OP) which incorporates the City's Directive 10 that specifically state which expenses are capital eligible and the expenses the hospital operation must incur in order to withstand the disruption in not having the full use of the facility and the impact on service delivery, are not capital eligible.

Ms. Youssouf asked if the cost of moving patients due to a capital project is not a capital expense or a cost on the expense side.

Mr. Aviles stated that it is related to the capital project but it is not capital eligible.

Mr. Covino stated that page 3 of the report reflected the reduction in FTEs by facility and page 4 showed the corporate-wide FTE variance by major categories. The bulk of the reduction was in environmental/hotel services, clericals, aides and orderlies.

Ms. Youssouf asked what was included in the managers' category which had the largest increase. Mr. Covino stated that the increase was due to the backfill of vacancies that were vacant in prior years as a result of the facilities effort to achieve its target and backfill after the year ended. There were eight medical record positions at Bellevue; four head nurses at Queens; staff increase for Breakthrough expansion at Generations+ at Harlem; and corporate compliance consolidation. In the tech/specs increase of 53 FTEs, 48 were related to behavioral health associates.

Mr. Rosen asked if the enterprise IT increase of 554 FTEs shown on page 3 was attributable to a consolidation of the staff at the facilities.

Ms. Zurack stated that the staff was transferred to the corporate centralized IT cost center.

Mr. Covino stated that on page 5, a comparison of overtime actual to budget showed a \$4.5 million increase in spending compared to last year of which \$2.5 million was due to hurricane Irene, the remaining \$2 million was related to labs and pharmacy techs, clericals, patient care techs and HCIs.

Ms. Youssouf asked how the overtime variance compared to last two years. Mr. Covino stated that the budget was \$2 million less than actual for last year. The budgets are not based on the actuals but rather the base budget with a targeted reduction.

Ms. Zurack added that the variance is fairly consistent with the prior year and the level of the variance is consistent; however, the issue relates either to under-budgeting or controlling expenses.

Mr. Covino stated that page 6, overtime by major service category comparing FY 2012 to FY 2011, nursing was down by 1%; plant maintenance down by 4.3% and all others were up by 8.9%. The trend reflects an increase in overtime spending where there are significant reductions in various key staffing positions such as clericals, special officers, and patient care associates. Page 7 nurse registry showed a \$10 million increase which is a significant change from prior years. Nurse registry not only includes registered nurses and LPNs but also nurse aides. There was an increase in one to one coverage for the ICU, CCU and emergency room at Jacobi, NCB and Bellevue; a training program at Lincoln and Bellevue for new staff and nurse shortages. Page 8 showed that there were no major changes in allowances compared to the prior year.

MEDICAID ELIGIBILITY REPORT – STATUS OF CONVERTING SELF-PAY PATIENTS TO MEDICAID

Ms. Katz stated that the reports are for FY 12 ending June 30, 2012. Ms. Katz reminded the Committee of the change in the reporting for the current FY 13, whereby the reports will be reported on a quarterly basis in order to coincide with the payor mix reports as agreed to by the Committee. The Medicaid eligibility report reflected a decrease in the number of Medicaid application submitted but there has been some improvement in the percentage of the applications resulting in eligible decisions by HRA. Last year, the percentage of approvals was at 88% compared to FY 12 at 89%. The overall submissions are less but more of the applications submitted are being approved.

PAYOR MIX REPORTS – INPATIENT, ADULT & PEDIATRICS

Ms. Katz stated that inpatient discharges payor mix percentage was at 96% corporate-wide for patients insured to the total. There were shifts in the payor mix across the Corporation. The Medicare downward trend is due to a shift to Medicare managed care and a bigger shift from Medicaid to Medicaid managed care and an increase in commercial. As part of the percentage of patients insured to the total there are more patients insured than in prior years.

Adult Payor Mix

Ms. Katz stated that 96% of the visits insured to the total and 92% of the patients were insured to the total which is slightly better than last year at 91% and 95% respectively.

Pediatrics Payor Mix

Ms. Katz reported that the Pediatrics payor mix was holding steady in both patients and visits insured to the total compared to last year at 98% in FY 12 and 97% in FY 11.

Ms. Cohen asked if HHC Option is an insured and self-pay is not. Ms. Katz replied in the affirmative.

Ms. Zurack added that as a point of clarification, 96% either insured or enrolled in HHC Options. From the perspective of healthcare policy, those HHC Options patients are uninsured. However, from an HHC perspective, if the patient was interviewed and cooperated with the requirements that patient is categorized as eligible for Options.

Ms. Katz, in concluding the reporting, added that those patients are included in the insured because they are not eligible for public health insurances.

Medical & Professional Affairs / Information Technology Committee **September 20, 2012 – As reported by Dr. Michael Stocker**

Chief Medical Officer Report:

John Morley, MD, Deputy Chief Medical Officer reported on the following initiatives:

- Radiology 24 x 7 x 365

In early 2011 an adverse event occurred that resulted, in part, from a delay in interpretation of imaging studies performed during "off hours". As a result the Corporation has committed to providing real time (within 30 minutes) interpretation of CT images done on a 24 x 7 x 365 basis by an

attending radiologist with privileges to provide final interpretations and to be available for discussion of the case after providing the interpretation.

Several of our acute care facilities already provide this coverage but we are in the final stages of having the same level of care at all 11 hospitals. Harlem Hospital Center will have the new schedule in effect by October 1st and the North Bronx Network will be in place in October. At that point all 11 hospitals will have a final interpretation of CT scans and chest radiographs and the treating physicians will be able to discuss any questions with the interpreting radiologist.

Most hospitals have chosen to outsource this service for night time/weekend reading but at least one hospital has chosen to provide the coverage with their own staff extending their work schedules. The two (2) vendors HHC hospitals are contracting with for night time and weekend services are vRad and NexxRad (Coney Island Hospital).

- Patient Centered Medical Home (PCMH) Practices

PCMH practices at each of our facilities have been working over the past few months to ensure that all primary care patients are linked to primary care providers and that this relationship is monitored and sustained overtime. HHC IT developed and launched the Patient Panel Management System (PAMS) early this summer to support the monitoring of the patient assignment activity, and has trained primary care front-line and management staff to work with PAMS to manage patient assignment protocols. Through these efforts, HHC PCMH practices have successfully assigned 82% of primary care patients to PCPs/care teams in FY 2012, an improvement of 11.4% since January 2012.

- Hospital-Medical Home (H-MH) Demonstration Project

HHC submitted applications for the New York State Department of Health Hospital-Medical Home (H-MH) Demonstration Program on behalf of our 11 hospitals on July 2, 2012. The H-MH Demonstration Program will make up to \$250 million available over the next three years to NYS teaching hospitals to support transition of their outpatient training sites to Patient-Centered Medical Home (PCMH). If successful, HHC is estimated to receive approximately \$28 million of the \$102 million to be disbursed in the first year of the demonstration, based on a formula derived from Medicaid volume and number of primary care residents receiving training at our facilities. Award notifications are expected sometime in September and successful applicants will then be required to submit a work-plan describing selected resident training continuity of care enhancements, care integration initiatives with focus on primary care and behavioral health integration, and inpatient safety projects. Continued funding will be dependent upon meeting certain performance milestones, including achieving Level 2 or 3 NCQA PCMH recertification by December 2013.

- The New York City Health and Hospitals Corporation ACO (HHC ACO)

The HHC ACO has filed an application to operate as a Medicare Accountable Care Organization (ACO), an initiative established by the federal Affordable Care Act that creates a new model of providing Medicare beneficiaries with higher quality care while reducing costs through of more efficient, better integrated care. The HHC ACO is specifically seeking to participate in the Medicare Shared Savings Program, a payment model that aligns payment rewards with performance based on quality, process and cost-reduction targets. The HHC ACO arrangement is a collaborative venture among HHC, its employed physicians, and a number of physician affiliate organizations, including Mt. Sinai School of Medicine, New York University School of Medicine and the Physician Affiliate Group of New York (PAGNY). To receive incentive payments, HHC ACO participants will have to measurably improve the health status of patients, adopt evidence-based clinical practices, and lower spending for the Medicare program by reducing unnecessary hospitalizations, readmissions and emergency room visits for designated patients. The HHC ACO application to the Medicare Shared Savings Program is expected to be reviewed by CMS in the next few months. If approved, HHC ACO will begin operations in January 2013.

- The Ambulatory Care Leadership (ACL) Council,

The Ambulatory Care Leadership (ACL) Council, whose members represent the ambulatory care leadership at HHC acute care facilities and Diagnostic and Treatment Centers, has ratified its new charter and mission whose aim is to advise and lead the strategic and operational changes in the delivery of ambulatory services at HHC so that it can function as an accountable care organization and deliver the *Triple Aim*. The Council, assisted by its three co-chairs, representing medical, nursing and administrative leadership, has selected as its initial focus, to establish action plans for arriving at a package of recommendations for ambulatory care governance, collaborative care model adoption and improving access to ambulatory care services.

- Dialysis Transition Task Force

A team of representatives from each site impacted (Bellevue Hospital Center and Elmhurst Hospital Center not involved) will be meeting monthly to design the transition to the vendor providing dialysis - topics will include the sequence and timeline for transition, reporting quality templates and formats, working closely with Labor for a smooth labor process, and related monitoring of the clinical contract parameters.

- Nursing Excellence Awards

The Nursing Excellence awards ceremony will be held on October 16th from 2pm-4pm at Harlem's new mural gallery. Six (6) individual nurses will be honored along with one team from across the Corporation. The awards are for: 1) Volunteerism and Service; 2) Education and Mentorship; 3) Professional Management; 4) Excellence in Home; 5) Community and Ambulatory Care; 6) Excellence in Clinical Nursing, Advancing and Leading the Profession; and the 7) Team Award. The venue is planned for Harlem's new mural gallery.

- Nurses Improving Care for Healthsystem Elders (NICHE)

Four new facilities are beginning the NICHE journey: Lincoln Medical and Mental Health Center, Elmhurst Hospital Center, Jacobi Medical Center and Coney Island Hospital. A grant was received from the Hartford Institute for Elder Care based at NYU to support this program. Three facilities have already achieved NICHE status: Queens Hospital Center, Harlem Hospital Center and North Central Bronx Hospital.

- HHC Plays Major Role in Statewide Behavioral Health Conference

This week the Office of Behavioral Health will make two separate presentations at the New York Association of Psychiatric Rehabilitation Services 30th annual conference, the largest mental health consumer attended conference in the State. The theme of the conference is "Keeping the Integrity in Integration." Joyce Wale, Senior AVP for Behavioral Health will be participating in a panel that will discuss what can be expected as the State moves toward managed behavioral healthcare. Marylee Burns, Senior Director for Mental Health Services, and Linda Richard, Consumer Affairs Coordinator will present on the importance of the use of peer health coaches in improving the health outcomes for people with mental illness.

- Changes to the State's Managed Behavioral Healthcare Plan

In January 2011, Governor Cuomo created a Medicaid Redesign Team to find ways to increase quality and efficiency in the Medicaid program and to reduce costs. One of the recommendations enacted into law was the creation of Behavioral Health Organizations (BHOs) that would be responsible for paving the way for behavioral health to enter into managed care. The expectation was that through data collection on long-stay patients and those who were frequently readmitted to inpatient psychiatric or detox services, the BHOs would be able to advise the State on the types of service redesigns and enhancements that would need to occur to decrease length of stay (LOS) and improve community tenure and prepare the way for managed behavioral healthcare. However, the BHOs resulted in an increased administrative burden to hospitals without producing useful results. Effective October 1, 2012, the two state agencies who oversee BHO performance, the NYS Office of Mental Health, (OMH) and the Office of Alcoholism and Substance Abuse Services (OASAS) have reduced the burden by changing the reporting requirements to focus on the more complex, difficult-to-discharge and frequently readmitted patients. It is hoped that this will result in more useful data to move into the second phase of managed behavioral healthcare. It is further expected that the State will delay implementation of Phase Two until 2014.

- IMSAL - Intern Orientation 2012

The IMSAL team embarked on its third year of delivering simulation training to incoming Emergency Medicine, Internal Medicine and Surgery Residents. Over the course of a 6 week period, approximately 500 interns were trained in Central Line placement utilizing the HHC Bundle System. The four hour hands-on course gives interns a chance to master the procedure using both the Internal Jugular and Subclavian Veins, as well as use of the HHC Bundle Kit and Ultrasound. Emergency Medicine residents were additionally trained in Basic Airway management, giving them a chance to practice BVM techniques, insertion of basic airway adjuncts and direct laryngoscopy. The residents also put their new "skills" to use in hi-fidelity scenarios. This year, over half of the residency programs elected to send their residents to IMSAL to be trained, which eliminated the cost of training incurred by the individual facilities, as well as increasing the number of residents IMSAL faculty could train. This year also marked the first year that guest facilitators from the local facilities joined IMSAL staff in delivering training: Dr. Nur-Ain Nadir, IMSAL's newest Simulation Fellow, Dr. Heather Mahoney from Bellevue Hospital Center, Drs. Nikita Joshi and Ian Julie from Kings County Hospital Center, and Dr. Nehad Shabareck from Lincoln Medical and Mental Health Center.

MetroPlus Health Plan, Inc.

Dr. Arnold Saperstein, Executive Director, MetroPlus Health Plan, Inc. presented to the Committee. Dr. Saperstein informed the Committee that the total plan enrollment as of August 31, 2012 was 436,735. Breakdown of plan enrollment by line of business is as follows:

Medicaid	368,883
Child Health Plus	16,102
Family Health Plus	36,886
MetroPlus Gold	3,157
Partnership in Care (HIV/SNP)	5,810
Medicare	5,897

Dr. Saperstein informed the Committee that this month, MetroPlus added 921 members. Their largest growth was in our Medicaid line of business. MetroPlus added 92 new enrollees in Medicare.

Dr. Saperstein provided reports of members disenrolled from MetroPlus due to transfer to other health plans, as well as a report of new members transferred to MetroPlus from other plans.

In the month of August, MetroPlus lost 1,128 members to Fidelis Care and 1,101 members to Health First. After more research, it appears that the MetroPlus dental transition to Healthplex in July may have contributed to this loss.

The 2013 Medicare Bids were submitted to CMS in June and accepted in August. Due to rate cuts and very high drug costs, significant changes had to be made to the Partnership in Care Plan (HMO SNP) for 2013. Monthly premiums increased from \$0 to \$23.70, copayments were increased and several benefits had to be cut from the package including hearing aids, transportation services, and vision services.

On September 1, 2012 the NYS 599 statute for Medicaid MCO's and FHP Plans' will commence requiring reimbursement to mental health clinics for services under the ambulatory patient group (APG) rate setting methodology. One challenge is that the 3M grouper for this change has not yet been released. The state has informed providers to hold their claims until the grouper is released. NYS will then only allow plans 2-3 days after the release to update their systems. An adjustment to premium rates for Mental Health APGs will be included in a July 2012 rate package and will be pro-rated for the implementation date. NYS indicated the impact for NYC is expected to be approximately \$33,000,000.

The Affordable Care Act (ACA) included a provision to expand primary care access and address physician shortages through an increase to primary care physician Medicaid reimbursement to of 100% RBRVS - Effective January of 2013. Eligible providers are those recognized by the American Board of Medical Specialties as: Family Medicine, General Internal Medicine, Pediatric Medicine, and recognized Sub-specialties.

MetroPlus continues to work very closely with HHC towards the successful implementation of the HHC Health Home. Membership outreach commenced on July 16, 2012. MetroPlus sent the initial mailing to eligible members and has routed care management calls to HHC for handling. The Health Home contract has been executed between MetroPlus and HHC. Enrollment is very slow so far. There are only 15 MetroPlus members in the HHC Health Home.

Mandatory enrollment for Managed Long Term Care (MLTC) began on July 2, 2012. The MetroPlus application for a MLTC License was completed, submitted and approved. MetroPlus has been granted a Provider ID. MetroPlus has started testing our systems with the NYS enrollment broker, Maximus as of August 24, 2012. MetroPlus is still waiting for their formal contract and license.

In 2011, NYS approved a mandate for coverage of autism services. This legislation will now be enacted and is effective November 1, 2012. The Mandate applies to all policies and contracts issued, or renewed, modified, altered or amended on or after November 1, 2012 and will affect approximately 14,000 MetroPlus Child Health Plus members. Every policy that includes coverage of physician services, medical, major medical or similar comprehensive-type coverage must provide coverage for autism screening, diagnosis, and treatment. There are no age limits or limits to visits that are solely applied to the treatment of autism spectrum disorder. Coverage is subject to a maximum benefit of \$45,000 per year per covered individual.

Medicaid Redesign Team Managed Care Benefit and Population Expansion changes continue to occur as MetroPlus moves to the end of 2012.

Effective October 1, 2012, Consumer Directed Personal Care (CDPAP) will be carved into the MetroPlus benefit package. CDPAP provides services to chronically ill or physically disabled individuals who have a medical need for help with activities of daily living or skilled nursing services. Services can include any of the services provided by a personal care aide, home health aide, or nurse. Recipients have flexibility and freedom in choosing their caregivers. The consumer or the person acting on the consumer's behalf (such as the parent of a disabled or chronically ill child) assumes full responsibility for hiring, training, supervising, and – if necessary– terminating the employment of persons providing the services. MetroPlus is in the process of securing a fiscal intermediary to provide paperwork facilitation, payroll, and benefits administration for this benefit.

Finally, effective January 1, 2013, New York State will transition the management of all non-emergency medical transportation services for enrollees in a managed care plan to LogistiCare, a regional transportation company. For the last six months, all Medicaid fee-for-service enrollees have been using this provider.

Action Item:

Authorizing the President of the New York City Health and Hospitals Corporation ("the Corporation") to negotiate and execute a contract with Epic Systems Corporation for an Enterprise-Wide Electronic Medical Record (EMR) System including the software license, installation, training and maintenance to be used throughout the Corporation's facilities. The contract will be for an initial term of ten years, with an additional five-year renewal option, exercisable solely by the Corporation, in an amount not to exceed \$302,807,986.

The resolution was moved for the full Board of Directors consideration.

Strategic Planning Committee – September 11, 2012
As reported by Josephine Bolus, RN

Senior Vice President Remarks

Ms. LaRay Brown greeted and informed the Committee that her remarks would include brief updates on federal and state issues and HHC's Breakthrough work.

FEDERAL UPDATE

Ms. Brown reported that Congress had been in recess since the beginning of August and had just yesterday, September 10, 2012. She added that, although the Senate's schedule had not yet been revealed, it was said that there are only seven session days scheduled between now and the elections, and only sixteen scheduled for the lame duck session in November and December.

Ms. Brown described the key items that remained to be completed before Congress adjourned as the following:

- The Sustainable Growth Rate (SGR), commonly referred to as the "doc fix" that governs Medicare reimbursement to physicians will expire unless extended before December 31st. If it is not extended, reimbursements to doctors will decline by 27%. A permanent solution will cost \$316 billion over 10 years.
- The Bush tax cuts expire unless legislatively extended. The Obama Administration wants to extend them only for those making less than \$250,000. The Republicans want to extend them in their entirety. It is unclear whether a "pay for" will be required.
- Under the Budget Control Act of 2011 (BCA), a sequester, across the board cut, totaling \$1.2 trillion over ten years will begin starting in January 2, 2013, unless some alternative approach to the deficit is adopted. The automatic sequesters will result in a 2% reduction for Medicare providers (\$123 billion 2013-21, including \$41 billion over 9 years from hospitals). Medicare beneficiaries and the entire Medicaid program are exempt.

There is concern in some quarters that because half of the sequester savings must come from Defense that some alternative should be enacted to avoid these reductions. Any change to mitigate the Defense cuts would come from domestic programs - with Medicare and Medicaid likely targets. The House earlier passed an alternative budget, which included extending the Medicaid DSH cuts as well as other cuts to ACA funding. The Senate did not take up the House budget stating that there was a budget already in place under the BCA.

- Appropriations to fund the federal government will expire October 1st. A bipartisan agreement for a Continuing Resolution through March 2013 was announced prior to the August recess but legislation has not yet been made available and no votes have been taken.

STATE UPDATE

New York State Submits Waiver to CMS

Ms. Brown reported that, last month, New York State had formally submitted a Medicaid Waiver proposal to the Centers for Medicare and Medicaid Services (CMS) to amend the existing waiver that the State of New York currently enjoys. If approved, the State could see \$10 billion in new funds over the next 5 years. In the waiver, the State laid out 13 areas that they are seeking to reform that would achieve the triple aim of improving patient care, improving population health and reducing costs. By their estimates, New York State calculated that the federal government would save more than \$17 billion over 5 years if the waiver is approved.

The Waiver categories and proposed investment amounts are the following:

- Primary Care Expansion - \$1.25 billion
- Health Home Development - \$525 million
- New Care Models - \$375 million
- Vital Access Provider and Safety Net Providers Programs - \$1 billion
- **Public Hospital Innovation - \$1.5 billion**
- Supportive Housing Expansion - \$750 million
- Long Term Care - \$839 million
- Capital Stabilization for Hospitals - \$1.7 billion
- Hospital Transition - \$920 million
- Workforce - \$500 million
- Public Health Innovation - \$395 million
- Regional Health Planning - \$125 million
- Waiver Evaluation and Program Implementation - \$500 million

Ms. Brown added that negotiations between the State Health Department and CMS are ongoing and are expected to continue over the next few months.

On a separate but somewhat related note, Ms. Brown reported that the State Department of Health had released their Medicaid Global Cap spending figures last month that showed State Medicaid spending continued to be below the \$15.9 billion cap. Spending for the 1st quarter of the State Fiscal Year was \$40 million (or 1%) below projections. She explained that many of the reforms that the State is seeking to build upon in the waiver to CMS have helped to keep spending under the cap since its inception 2 years ago. This helps to reinforce the State's argument to CMS that the waiver would result in significant savings.

HHC INITIATIVE Breakthrough

Ms. Brown provided an update on the corporation's Breakthrough work on behalf of her colleague, Joanna Omi, Senior Vice President of the Division of Organizational Innovation and Effectiveness. She reported that the Division was working to ensure that Breakthrough gains can be sustained. One way to do this is to reduce the waste of duplicated effort and set the 'best known way today' as a corporate-wide standard. She reported that the Division of Organizational Innovation and Effectiveness is working with facilities to create standards for the display and management of outcome and KPI data; for setting and managing toward financial targets (including the role played by leadership and committees at various levels); and to improve event preparation, conduct and follow-up. Rather than the traditional view of standards that promote visions of Dilbert-like automatons, Breakthrough Standard Work identifies the resources and action steps needed for repeating activities to be consistently and effectively applied without defect, freeing significant brain power for the more challenging, creative thinking required for continued organizational health.

Ms. Brown added that Ms. Omi, on behalf of the Division, would bring a resolution to the Committee for consideration next month. This resolution will propose funding for the final year of a three year contract with Simpler North America, LP, the firm that supports HHC's Breakthrough efforts.

Information Item:

The Lingering Cloud of 9/11 – Hope and Healing Through Art and Expression

Terry Miles, Executive Director, WTC Environmental Health Center

Irene David, Phd, Director, Therapeutic Arts, Bellevue Hospital Center

Nomi Levy-Carrick, MD, MPhil, Psychiatrist & Mental Health Director, WTC Environmental Health Center

Ms. Brown introduced Terry Miles, the Executive Director for HHC's World Trade Center Environmental Health Center. Mr. Miles thanked the Committee for the opportunity to present HHC's World Trade Center Environmental Health Center program, especially on this day, the 11th Anniversary of 9/11. He noted that various handouts were available for Committee members and meeting attendees including the "We Go On" brochure which was produced last year. "We Go On" was HHC's claim theme last year for the 10th anniversary. He added that the World Trade Center Health Program and the federal program have put out their first newsletter. One of HHC's WTC EHC patients is highlighted in that newsletter. This patient is a young woman who was a child at when the event of 9/11 occurred. She is now a young woman and her story is highlighted.

Mr. Miles shared a flyer with the Committee of events that had been organized at Bellevue Hospital Center and at Elmhurst Hospital to commemorate the 11th Anniversary of 9/11. He stated that he would provide brief remarks and would then turn the presentation over to Dr. Nomi Levy-Carrick, HHC's WTC EHC Mental Health Director to provide an update on the mental health aspects of the program. Following Dr. Levy-Carrick's presentation, Irene David, M.D., Director of the WTC EHC Therapeutic Arts program would conclude the presentation. Mr. Miles informed the Committee that Dr. David had been recently awarded The American Art Therapy Association's Lifetime Achievement Award.

Mr. Miles provided the Committee with an overview of the structure of the World Trade Center Program. He explained that the legislation called for the creation of data centers which are primarily responsible for data analysis and claims processing. There are three data centers: one at the Fire Department of New York, one at HHC and the third at Mount Sinai School of Medicine. There are four Clinical Centers of Excellence. HHC's WTC Environmental Health Center is one of the four Clinical Centers of Excellence. There is specific language in the legislation concerning the New York City Department of Health and Mental Hygiene's Registry. The Registry functions as a referral source to help those listed on the registry get into treatment; it also conducts surveys, research and analysis. The registry is not itself a treatment program. It works in partnership with HHC's WTC Health Center Program to help people get into care.

There are three advisory committees. These committees include the Survivor and Responder Steering Committees, and the Scientific and Technical Advisory Committee (STAC). The Survivor and Responder Committees have been assigned, via legislation, to directly advise the Responder and HHC's WTC Health Center Programs. While the STAC provides guidance, their input/guidance is less direct. HHC's WTC Health Center program has three clinical sites. These sites are located at Bellevue Hospital Center, Elmhurst Hospital and Gouverneur Healthcare Services. Mr. Miles reported that 613 new patients had been enrolled in HHC's WTC Health Center program, since October of 2011.

Mr. Miles announced that the annual ad campaign targeting key City bus and subway routes was launched on September 1, 2012. Bus shelter advertisements in key immigrant communities throughout the City were added to this year's campaign. This is because 91% of new enrollees

do not speak English. Mr. Miles stated that the calls to the WTC Hotline had increased significantly, from one to two calls per week from individuals who do not speak English to an average of 15 calls per day.

Mr. Miles stated that the theme of the 11th Anniversary of 9/11 was "The Lingering Cloud." He stated that the health effects of 9/11 were continuing, and the efforts are still ongoing to meet those health care needs. He said that the dust may be gone, but the cloud does remain. On this day, 11 years ago, there was a bright blue sky just like there is today.

Dr. Levy-Carrick began her presentation by stating that it was her goal, through her presentation, to answer two basic questions. The first question is what is the WTC EHC's mental health program? The second is who are the patients who being are treated by the program? She stated that she would also describe some of mental health challenges that these patients have endured.

Dr. Levy-Carrick explained that the mental health program provides multi-modal mental health care. As a reminder for the Committee, she described the survivors as including local workers, residents, cleanup workers, people who were students at the time and passersby. It is a very homogenous mix level. Different levels of education, different languages and different socio-economic backgrounds.

She reported that the mental health program has a team that consists of psychologists, psychiatrists and social workers who coordinate closely and meet regularly in interdisciplinary conferences. They meet on a monthly basis with the medical teams to coordinate the care of patients who have particularly complex cases.

New patients continue to come into the program for screening. Others return for monitoring and others remain in ongoing treatment with the program. Screening and monitoring are conducted at a clinical encounter. An online questionnaire is completed during the encounter. Patients come into a room and meet with a social worker or psychologist. Structured questionnaires are administered to patients to screen for PTSD, anxiety and depression, substance abuse, other 9/11 related issues, panic disorder and relative adjustment disorder (i.e., a 9/11 related medical problem).

Dr. Levy-Carrick highlighted some of the immediate and direct psychological stressors that individuals who were "there" had experienced. She explained that many individuals witnessed death and destruction. Some experienced being covered in the dust cloud, the loss of loved ones and colleagues. Many continued to face ongoing psychological stressor. She reminded the Committee that the Ground Zero fires burned for nearly four months. This was not just the initial terrorist attack. September 11th was also an environmental disaster. There was continuous exposure to toxins and images of the disaster, loss of homes, income, social supports, and also the development of chronic and for some people disabling medical illness. These medical conditions include respiratory illnesses that wax and wane, and are also progressive.

Dr. Levy-Carrick described the major categories of disorders that are being treated by the program. They include PTSD, anxiety, depression, substance abuse, alcoholism (especially), and adjustment disorders to 9/11 related conditions. There are also symptoms that cut across all of these diagnoses, or fall just outside of their effective guideline, like insomnia, difficulty sleeping, chronic persistent headaches, memory and attention problems, interpersonal difficulties and chronic pain. She added that the interplay of the medical and mental health, that makes the WTC Health program, in so many ways, a unique program. The WTC Health program addresses the needs of patients in a very integrated way. Because respiratory symptoms can cause psychological distress of themselves, they can exacerbate an underlying disorder. They can also function as a reminder. They are triggers of the traumatic event. One of the unique things about PTSD is that the memory itself can trigger an entire physical response. You don't have to always see something or hear a loud noise or become startled. You can remember something. You can be short of breath. You think about what made you short of breath in the first place. With all of those initial, psychological stressors, the raw emotion, you feel like you are back in the dust cloud, you feel like you are back in the building. So it can be quite a cycle.

Dr. Levy-Carrick explained that sometimes there is misperception of what is really occurring. Sometimes patients would say in that moment, I don't know if I am having a panic attack or whether I am having an asthma attack. So it becomes difficult to treat. Remaining attuned to that and helping patients counteract that is something that the program strives to do on a regular basis. The idea is that if we have an integrated program that works to improve and address mental health issues, it would also improve the efficacy of medical care. If depression is keeping people from getting to their appointments, if anxiety is keeping them from focusing, these are the things that the program addresses.

Dr. Levy-Carrick informed the Committee that there are ongoing challenges. Some are just helping patients to move forward with these chronic issues. A patient with PTSD that goes untreated for a long period of time is at risk of losing their friends, their job and any other type of related attachments. The program has to address these issues with complimentary approaches.

Dr. Levy-Carrick stated that a key goal is to also analyze the outcomes of the program. There are recurring monitoring evaluations, which provide a good structure and touch point. Notwithstanding, the program aims to find other ways to demonstrate the improved level of functioning that patients are experiencing.

Dr. Levy-Carrick described the indications for therapy. She added that there is a need for different medical modalities to address different levels of functioning and integration of patients, and those change over time. She informed the Committee that in the remaining minutes of her presentation she would describe why people feel why they can't move on after 11 years. Some of the broad themes that occur include struggles with conflicting impulses while trying to move forward. Guilt of survival wipes away the guilt of living. People have a conscious sense

of lack of urgency in their life; and an overwhelming experience of loss of control that has pervaded their life and many other aspects of their decision making and interpersonal relationships.

Dr. Levy-Carrick described some of the common themes of issues that WTC EHC patients are faced with by age group as the following:

- Patients in their 20s who were students at the time with asthma find that some of their avoidance, anxiety symptoms that remitted now are never remitted. This condition is now interfering with their ability to build professional careers and professional lives.
- Patients in their 30s who were starting their careers downtown in finance, law or education describe a fog that has never lifted and now find a lack of trust. They face fear including being future oriented, of magical thinking, avoidance, anger and other symptoms.
- Patients in their 40s with young families have experienced difficulty in their careers. They panic because their asthma worsens as they try to keep up with their kids in the playground. Their occasional alcoholic binge with friends has turned into a daily and destructive overwhelming change.
- Patients in their 50s who lined up to help with the cleanup efforts were often not provided with face masks or other protective equipment. They include immigrants who were proud of the hard work they did for themselves and their families. They were part of the patriotic effort of rebuilding, and now they are physically disabled with respiratory and other problems. They are struggling with medical issues, feelings of low self-worth as well as financial stresses.
- Patients in their 60s and of all ages who have sought care elsewhere until they lost jobs are now overwhelmed by their medical bills. They are relieved to find a center of excellence that can provide for their welfare and related medical and mental health problems without out of pocket expenses.

Dr. Levy-Carrick stated that, since the start of this year, the program has found that over 60 percent of patients who come through for screening and monitoring have some symptoms of PTSD, anxiety and depression. They don't all want or need treatment, but many of them do. They have some symptoms. Some people are not ready for treatment. Some people are. Some people are really anxious to finally get going, which the programs helps them to do. The program provides talk therapy and medication management. For those patients for whom neither of these approaches are the right fit or enough, the program is fortunate to be able to coordinate with the therapeutic arts department to help these patients manage their stressors.

Mr. Rose, Committee Member, asked for clarification regarding the number of patients being served by the WTC Health program. Mr. Miles explained that, of the 6,500 patients, roughly 4,000 are actively in care right now. The program conducts continual outreach to the remaining 2,000 to encourage them to seek out care. Mr. Nolan, Committee Member asked how long would the WTC Health Center program's funding remain in place. Mr. Miles responded that, legislatively, it was designed for five years. There are four years left, but there is the possibility of a sixth year if those funds remain. He added that a recent conference call had occurred with some key legislators including Caroline Maloney and Joe Hannah to form a strategy to go to Congress even this year to extend the funding. Mr. Nolan inquired if the program was 100% federally funded. Mr. Miles responded that is one hundred federally funded for the responder program. This is different for HHC's WTC Health program, which is the Survivor program. In the Survivor program, if someone has insurance, HHC has to bill that insurance first. Ms. Cohen asked if this included Medicaid. Mr. Miles responded affirmatively. He added that, an unintended consequence of the Zadroga Act is that Medicaid is the payer of last resort in New York State. Accordingly, HHC does not bill for patients who are covered by Medicaid.

Dr. Irene David informed the Committee that the premise for the therapeutic arts program is that one can bypass the verbal censor to access the inner mind more readily. That is, just to externalize in this non-threatening environment and modality via expression, and then the next phase of inner life. If they are ready, they can use art as a catalyst for reflection and insight. What is showing in the art productions can be revealing for caregivers in terms how patients are seeing themselves and their life challenges. This is about processes and not art quality or talent. This is a life enhancing activity. The program encourages group participation because isolation is a part of the problem.

Dr. Irene David shared several works of art that were completed by patients enrolled in the program

340 B Project Presentation

Arthur Wagner, Senior Vice President, South Brooklyn & Staten Island Health Network

Joseph Quinones, Senior Assistant Vice President Operations

Vincent Giambanco, Director of Pharmacy, Materials Management Division

Ms. Brown introduced Mr. Arthur Wagner, Senior Vice President, HHC's South Brooklyn and Staten Island Health Network to lead the presentation on HHC's outpatient 340B enhancement initiative. Mr. Wagner provided the Committee with some background about the 340B program. He informed the Committee that the 340B program was established to assist public safety net programs to create a new source of income to offset expenses for safety net patients. Disproportionate Share Hospitals - DSH" (are eligible for the 340-B program. This means that all HHC hospitals are eligible. Mr. Wagner reported that, on April 5, 2010, the 340B program was amended to allow covered entities to establish multiple contract pharmacy arrangements to dispense 340B discounted drugs to eligible patients of the covered entity, which are

safety net providers and 340B eligible hospitals. He added that, it is a complex program in order to monitor the way the drugs are allocated to the pharmacies and to the patients. At this time, HHC is developing systems to be able to move this project forward. .

Mr. Wagner reported that HHC hospitals dispense roughly three million outpatient prescriptions per year. He estimates that roughly nine million prescriptions are being filled in retail pharmacies throughout the New York City area. This enhancement initiative will focus on three HHC hospitals including Jacobi Medical Center, Elmhurst Hospital and Woodhull Medical and Mental Health Center. HHC's vendors have done some work based on the information that was collected from the prescription systems that are currently in place. As a result of this analysis, three pharmacies were identified that have a fairly large number of prescriptions being issued by those hospitals that would fit the 340B program. This is what is being targeted.

Mr. Wagner discussed the financial implications of this new initiative and showed why it appears that there really is no down side to this new method. To demonstrate this point, he discussed how the program would work using the Nexium, a drug used to treat ulcers. He informed the Committee that the non 340B and 340 reimbursement amount for Nexium is \$243. The cost of this drug for non 340B is \$218. The cost of the drug with 340B is 29 cents. He explained that HHC would be taking advantage of that price swing and billing the appropriate third parties in order to come up with that revenue source. The dispensing fee for a non 340B is on an average of \$3.75 to the pharmacy. For pharmacies to collaborate with HHC the dispensing fee would have to be significantly higher -- \$50 is being used as a rough estimate. That fee would have to be negotiated with the individual pharmacies, which could be less or could be slightly higher. The transaction fee, that is a fee that HHC would have to pay to the vendor to capture X for them to do the background work in order to coordinate the whole program. That fee would be one dollar per prescription. Co-pays would remain the same to the individual. The net income on that one medication is a significant amount of revenue. Mr. Wagner added that the patient would not experience anything different. They can go to whatever pharmacy that they are used to going to, and this would be blind to them. It is not an issue at all for the patient. It has more to do with the pharmacy, the hospitals and the vendors that are providing those medications.

Ms. Bolus asked for those patients who are retirees who belong to Express Scripts get this \$340B. Mr. Wagner explained that these patients would do the exact same thing, and they would not see any difference in the way that they get their prescription filled. This is all behind the scene. It is all in the background. It does not affect the patient at all. Ms. Cohen asked which payer is this good for. Mr. Giambanco, an HHC pharmacist responded that this is for all qualified payers including Express Scripts, MetroPlus and CVS. The only drawback is that this would not work for patients who are enrolled in Medicaid or Medicaid managed care. Mr. Wagner explained that Medicaid still gets a rebate and that was a problem in the past. This is because Medicaid has some issues with 340B. They weren't sure if it was to their advantage.

Mr. Wagner stated that based on the 9 million scripts filled in the community, HHC expected 18 percent of those patients to be eligible for the 340B program. Of that total, the estimated number of eligible scripts for the 340B program is estimated to be 1.6 million. He added that HHC took a very conservative estimate of capturing 10 percent of those prescriptions in year one totaling 162, 483 scripts. The expected revenue per script minus the administrative fee would be roughly \$78 per prescription. He added that the scripts that pass the financial entity because of the generics may not go through the 340B because of the low price. The estimated revenue for those scripts is estimated to \$77 per script. The total revenue that is expected would be \$6.2 million. As HHC adds additional pharmacies, it expects to get a higher market share of those prescriptions. In year three, revenue would increase to \$18 million. President Aviles asked if there is a revenue opportunity with regard to any of the generics, or is most of this related to brand name medications. Mr. Wagner clarified that most of it is related to brand name. President Aviles also asked if Mr. Wagner had factored in the reality that in the main, HHC has been recently successful in having medications prescribed in generic form made available. Mr. Wagner responded that HHC is currently at 75% generic and that has been factored into their analysis.

Ms. Cohen commented that, one of the primary risks regarding the 340 B project is a political risk that this would not continue for the long term. What would be HHC's investment in something like this, and how quickly would HHC be able to recoup that investment. Mr. Wagner responded that the upfront investment is minimal. Some systems are already in place. HHC has done a lot of work behind the scenes.

Ms. Cohen asked how hard it would be to unwind if the policies change over. Mr. Wagner responded relatively easily. The contract will detail specifically if the law is changed, how this would change. Ms. Brown asked would there be contracts with specific pharmacies or pharmacy groups. Mr. Wagner responded affirmatively. Ms. Brown asked, in that contract, if there would be consideration for if, for some reason, the program ceases, there would be somewhat of an escape clause for HHC, if HHC no longer participate in this initiative with that pharmacy or with that retail pharmacy. Mr. Wagner responded affirmatively. Mr. Quinones added that there would be a 30 day out clause. So there would be a 30 day notification that would be required, and then HHC would be out. HHC would have to reconcile refills on the drugs.

Mr. Wagner further explained how the process would work. He said the physician writes the prescription. The patient goes to the pharmacy. The pharmacy fills the prescription, and the information goes off to the pharmacy benefit manager. It goes off to Capture RX who does an audit. It goes back to the pharmacy to say okay, it is okay to go. Then it goes also to HHC's vendor to ensure that those medications are monitored on an appropriate basis. The prescriptions themselves, the medications themselves have to be replaced directly to the 340B program. There will be some inventory set up. Again, this is all done in the background through IT.

Ms. Brown introduced to the Committee other key individuals who had been engaged in this initiative. These individuals include Joseph Quinones, Vincent Giambanco, Brian Wilson, Krista Olsen, Lori Bond, and Jack Sczeganowski. Mr. Brian Wilson and Mr. Jack Sczeganowski are respectively the Vice President and Chief Operating Officer of Capture RX.

SUBSIDIARY BOARD REPORT

HHC Accountable Care Organization (ACO) - June 26, 2012; July 25, 2012 and August 29, 2012 As reported by Mr. Alan Aviles

In summary, over the course of the three meetings the Board adopted resolutions that established the legal framework for its conducting business in furtherance of the ACO's purpose. They authorized, among other things, the filing of tax forms, establishment of bank accounts, the adoption of a corporate seal, the adoption of bylaws, and the elections of officers.

In addition, the HHC ACO Board received regular updates on the status of the filing of its application with CMS for certification. The Board also ratified the performance indicators in the affiliation agreements as benchmark indicators in furtherance of the purposes and goals of the Medicare Shared Savings Program, and as necessary start-up arrangements that qualify for the Medicare ACO Pre-Participation Waiver from certain fraud and abuse statutes, including federal law prohibiting "gainsharing." The Board designated Dr. Ross Wilson to be responsible for the QA functions of the ACO, and Ms. Marlene Zurack to be responsible for the audit functions of the ACO. It also reviewed a model participation agreement that included a general formula for distributing shared savings. The formula general provides, that after costs of the ACO are deducted the remaining savings will be distributed among the participants and HHC in a fifty-fifty split.

Finally, the Board expanded its composition from five to eight members so as to include a Medicare Beneficiary, as required by regulations, the PAGNY CEO, and a Non-HHC Participant to be selected by a majority of the Non-HHC Participants.

The constellation of the Board members is as follows:

Alan D. Aviles	Chairman
Jeroman Berger-Gaskin	Medicare Beneficiary Director*
Dr. Luis R. Marcos	PAGNY CEO Director*
Antonio D. Martin	Director
Salvatore J. Russo	Secretary
To Be Determined	Non-HHC Participant*
Dr. Ross L. Wilson	Chief Executive Officer
Marlene Zurack	Treasurer
*New members to be approved by the HHC Board of Directors	

*** * * * * *End of Reports* * * * * ***

**ALAN D. AVILES
HHC PRESIDENT AND CHIEF EXECUTIVE
REPORT TO THE BOARD OF DIRECTORS
SEPTEMBER 27, 2012**

**HARLEM HOSPITAL OPENS THE MURAL PAVILION AND
UNVEILS ITS HISTORIC WPA MURALS**

Earlier today Mayor Bloomberg and I were joined by several board members and many HHC senior leaders to mark the completion of the main construction phase for one of the largest major public hospital modernization projects in the city's history at the opening of the new Harlem Hospital Center Mural Pavilion. The new \$325 million healthcare facility will expand access to preventive health services, emergency room care and specialty care. It is equipped with state-of-the-art accommodations that will better address the community's high rates of asthma, cancer, diabetes, heart disease, HIV/AIDS, and stroke. The Pavilion also features historic murals by African-American artists that have been restored and are reflected in the block-long glass façade of the new facility. We were joined at the ribbon-cutting ceremony by Harlem Hospital Center Executive Director Denise C. Soares and HHC's new Global Ambassador Kasseem "Swizz Beatz" Dean.

The new six-story, 195,000-square foot Pavilion connects two major hospital buildings, the Martin Luther King, Jr. Pavilion and the Ronald H. Brown Ambulatory Care Pavilion, creating one large, integrated campus for the 286-bed Harlem Hospital Center. The Mural Pavilion houses a number of suites to serve the hospital's 232,353 annual outpatient visits, including the Bariatric Center of Excellence, surgical clinics, women's imaging department, and pre-admission testing suites. A new chronic hemodialysis unit will double patient capacity and one of the floors will have the new adult intensive care and burn units. The Pavilion will also house the new Adult and Pediatric Emergency Departments, which will be fully completed in 2013.

The Mural Pavilion was designed by architectural firm Hellmuth, Obata + Kassabaum, Inc. (HOK). The Dormitory Authority for the State of New York (DASNY) was the program manager and managed the budget, consulting architects, engineers and the construction management team.

The Mural Pavilion also features a special public art gallery space to showcase the hospital's historic Works Progress Administration's Federal Art Project (WPA) murals. Originally created in the 1930s, these powerful artworks were the first major commissions awarded to African-American artists by the U.S. government and were removed to undergo restoration six years ago. Harlem's WPA murals by artists Vertis Hayes, Alfred Crimi, and Charles Alston are now fully restored and on permanent display in the hospital's Mural Gallery. The culturally and historically significant 1937 mural – *Recreation in Harlem* by Georgette Seabrooke – is also on exhibit in the atrium while it undergoes restoration.

The ceremonies were a powerful and emotional affirmation of the hospital's status as the healthcare touchstone of the community, as well as celebration of investment that will now

ensure that it can deliver state-of-the-art patient-centered services in clinically advanced and comfortable settings. My thanks to Iris Jimenez-Hernandez, Denise Soares, Sylvia White, and all those who were a part of the Harlem Hospital modernization project and made the Mural Pavilion a brilliant reflection of HHC's mission.

EVENING FUNDRAISER HONORS DOCTOR WHO HELPED SAVE MLK JR., INTRODUCES HHC GLOBAL AMBASSADOR KASSEEM "SWIZZ BEATZ" DEAN

The ribbon-cutting begins a series of events to celebrate the opening of the new Harlem Hospital Center. I invite you to join me tonight at the Mural Pavilion for a spectacular evening and fundraiser to mark the opening of this new landmark in Harlem, view the unveiling of the famed Works Progress Administration's Federal Art Project (WPA) murals, honor the hospital's heroes, and launch HHC's philanthropic relationship with artist Kasseem "Swizz Beatz" Dean.

The evening event will begin with a celebratory gathering on the Pavilion's stunning terrace. During an intimate ceremony, The Fund for HHC and Harlem Hospital Center will honor Dr. John W.V. Cordice, the only living member of the surgical team that saved the life of the Reverend Dr. Martin Luther King, Jr. in 1958.

The fundraiser will also mark the first public appearance by Kasseem "Swizz Beatz" Dean as the Global Ambassador for HHC. Swizz Beatz, a famed musical producer, visual artist, and philanthropist, has announced his commitment to help HHC extend its positive healthcare messages to broader audiences and to ensure they resonate for young people, strengthening HHC's ability to provide care to underserved populations.

I hope you join me, Harlem Hospital Center, and The Fund for HHC at this historic event and fundraiser.

HHC HEALTH & HOME CARE EXPANDS TO PROVIDE SERVICES IN BROOKLYN

Brooklyn residents who need quality home-based services will soon be able to benefit from the care provided by HHC Health and Home Care (H&HC). In August 2012, the State of New York Public Health and Health Planning Council selected the HHC home care agency to be certified to serve the borough of Brooklyn and expand its services currently available to residents in the Bronx, Manhattan and Queens.

The certification will be an asset to the Corporation as we expand into ACO's, health homes and other models of care which focus of transitions of care. In order to receive certification by the state, an interested organization had to demonstrate how it could improve access to home health services, advance the state's Medicaid Redesign Team initiatives to reduce costs while maintaining quality, adopt a comprehensive quality assurance plan, enhance care coordination, improve patient choice and improve quality outcomes.

The competition to fill the service gap for home health services was fierce. Of the more than 80 organizations who submitted applications, 14 proposals moved forward in the selection process. But according to the review panel chair, the Health and Home Care group application was the only one worthy of an A+ and was the only organization to receive full approval to operate in Brooklyn.

H&HC is the certified home care agency of the New York City Health and Hospitals Corporation that provides expert home-based nursing services, as well as physical, occupational, speech therapy, and other services that may be prescribed by the patient's plan of care. Its specialized services reach patients with specific health care needs in home-based long term care, maternal-child health, hi-tech/infusion, behavioral health, and HIV/AIDS.

H&HC will soon have hospital-based Intake Nurses stationed in the three HHC acute care hospitals in Brooklyn -- Coney Island, Kings County, and Woodhull -- and will begin to work with medical staff at those facilities to coordinate patient care during the transition from hospital to home-based care setting. The home health agency expects to be fully operational to serve Brooklyn by early spring of 2013.

I know the Board joins me in thanking Home and Health Care Executive Director Ann Frisch for her outstanding work. This achievement is another example of her tireless commitment to expanding the services we provide to our community.

FUND FOR HHC DONATES \$38K TO PARTNERS IN HEALTH FOR MENTAL HEALTH PROGRAMS FOR HAITI EARTHQUAKE SURVIVORS

The Fund for HHC recently donated \$38,000 to Partners in Health (PIH), a Boston-based group that has been working in Haiti since its founding in 1984. The grant will support PIH and its sister organization Zanmi Lasante in their service throughout affected areas in Haiti to help adults, children, and families dealing with mental health issues.

The grant is part of HHC's Haiti Relief Fund initiative, an effort managed by The Fund for HHC that appealed to HHC employees for their help in addressing the tragic aftermath of the Haiti earthquake in 2010. Last May, the generous response by HHC's staff initially led to a donation of \$130,000 to the Mayor's Fund for New York City which was directed toward the urgent immediate response to the tragedy in Haiti. Donations have continued to come in, enabling The Fund for HHC to make this additional grant to PIH. The funds will bring PIH closer to its goal of establishing the foundation for the provision of sustainable, long-term mental health services in Haiti.

The PIH grant reflects the special relationship HHC has with New York City's Haitian community, the second largest Haitian population in the United States, outside of Florida. As of 2008, more than 180,000 people of Haitian descent were living in NYC, with the vast majority in Central Brooklyn, where Kings County Hospital Center has long been a caring resource for the largely immigrant population.

You can read more about The Fund's donation to PIH on The Fund for HHC's website www.thefundforhhc.org , and the organization's website, www.pih.org . PIH will also use social media outlets – Facebook and Twitter – to publicize the donation to their many followers.

HHC BOARD OF DIRECTORS CONSIDERS ADOPTION OF NEW ELECTRONIC MEDICAL RECORD

On your agenda today is a resolution to enter into a 15 year contract with Epic Systems Corporation to provide a new enterprise-wide electronic medical record system (EMR) that will meet the needs of HHC's large integrated healthcare delivery system to improve patient care, control costs, and ensure seamless transitions for patients who need access to different services throughout our system.

The contract for the new Integrated Clinical Information System Electronic Medical record would be executed later this year and is not to exceed \$303 million over the 15 years. It will include the initial purchase of the software and database licenses, professional services to support the implementation, testing and technical training, the annual maintenance of the software, and database support and upgrades.

The Epic System is a trusted, proven product with advance capabilities. The system is scalable to the size and performance requirements of HHC and able to meet the unique requirements and workflows of facilities and programs throughout the HHC network of healthcare service providers. This EMR system conforms to emerging and evolving HIT standards and utilizes modern technology to allow for interoperability within the HHC system as well as with external systems, Health Information Exchanges (HIE's) and other providers.

The Epic product is used by large and complex healthcare systems across the US, including Kaiser Permanente, Providence Health & Services, Children's Medical Center in Texas, North Shore University Health System and Stanford University Medical Center, among many others.

HHC put in place a comprehensive, competitive process to evaluate interested companies who are leaders in the marketplace and select an EMR product that can meet the health IT needs of the organization going forward. I am confident that the rigorous process used to evaluate competitors for this contract has yielded an excellent choice for HHC and I urge your support.

HHC FILES APPLICATION WITH CMS TO OPERATE AS ACCOUNTABLE CARE ORGANIZATION UNDER MEDICARE

As a subsidiary of HHC, HHC ACO Inc. has filed an application to participate in the Medicare Shared Savings Program as an Accountable Care Organization (ACO). Established under the Affordable Care Act, this initiative creates a new model for providing Medicare beneficiaries with higher quality care while reducing costs through more efficient,

better integrated care. The HHC ACO is specifically seeking to participate in the Medicare Shared Savings Program, a payment model that aligns payment rewards with performance based on quality, process and cost-reduction targets. The HHC ACO arrangement is a collaborative between HHC and its physicians. To receive incentive payments, HHC ACO participants will have to measurably improve the health status of patients, adopt evidence-based clinical practices, and lower spending for the Medicare program by reducing unnecessary hospitalizations, readmissions and emergency room visits for designated patients. The HHC ACO application is expected to be reviewed by CMS in the next few months. If approved, HHC ACO will begin operations in January 2013.

Resolutions that address several HHC ACO operational issues are included on today's agenda.

FEDERAL UPDATE

Congress, in recess since the beginning of August, returned for only a few days to pass the continuing resolution to extend through March 2013 the funding for the federal government, which would have expired October 1. They will reconvene after the elections. Although the Senate schedule has not been revealed, the House has scheduled only 16 session days for the lame duck session in November and December. There are a number of actions which Congress will probably address before the end of the session.

The Sustainable Growth Rate, commonly referred to as the "doc fix", that governs Medicare reimbursement to physicians will expire unless extended before December 31. If it is not extended, reimbursements to doctors will decline 27%. A permanent solution will cost \$316 billion over 10 years so there is likely to be another one-year patch.

Under the Budget Control Act of 2011, a sequester (or across the board cut) totaling \$1.2 trillion over ten years will begin in January 2, 2013 unless some alternative approach is adopted during the lame duck session. The automatic sequester will result in a 2% reduction for Medicare providers. HHC would lose \$9.5 million in 2013 and \$82.9 million from 2013 to 2021 in Medicare reimbursement. Medicare beneficiaries and the entire Medicaid program are exempt from sequester reductions. The WTC program, which reimburses for claims submitted, is not exempt from sequester, however, and would lose \$14 million – a 7.6% cut – in 2013.

The elections will impact what occurs in the lame duck session and next year.

President Obama's Administration supported cuts of \$716 billion (over the next 10 years) to Medicare providers as part of the Affordable Care Act to offset some of the costs of expanded coverage. The Administration came to an agreement with various stakeholders, including the American Hospital Association, on these Medicare reductions and other cuts. As an example, the hospital industry also reluctantly accepted deep Medicaid and Medicare DSH cuts predicated on major coverage expansions. HHC has not supported the Medicaid DSH cuts, which cost HHC in the out years approximately \$421 million per year, and now

HHC is even more concerned about slashing DSH allocations in light of the recent Supreme Court decision bringing the full scope of the Medicaid expansion into question.

Former Governor and Republican nominee Mitt Romney has pledged to repeal the ACA.

As the House Budget Chairman, Mr. Romney's running mate, Paul Ryan, has made two different proposals for Medicare - both of which feature a premium support or voucher proposal that would have seniors buy private insurance with some federal funding support for their premiums. Over time, this proposal shifts the risk of increased Medicare costs to seniors, and it is projected that many beneficiaries ultimately would find that their voucher would not allow them to purchase a package of benefits comparable to that which Medicare now provides.

Medicaid block grant proposals are included in each of Chairman Ryan's budgets and Romney supports this radical change to the Medicaid program. The Medicaid block grant proposal would save the federal government money while shifting the risk and added costs to the states. These proposals cut federal Medicaid spending by \$810 billion over 10 years. According to a Kaiser analysis, the Ryan Medicaid Block Grant would cost New York State \$141 billion from 2012 to 2021, rising to \$25.5 billion in the year 2021 alone with a 30% loss that year in Medicaid revenue to hospitals in NY State.

NEW YORK STATE SUBMITS WAIVER TO CMS

Last month, New York State formally submitted a Medicaid waiver proposal to the Federal Centers for Medicare and Medicaid Services (CMS) to recapture for investment in continuing state Medicaid reform efforts a portion of the estimated \$17 billion to be saved by the federal government over the next five years. If the waiver proposal is approved, the State could see \$10 billion in new funds over the next 5 years. In the waiver, the State laid out 13 areas that they are seeking to reform that would achieve the triple aim of improving patient care, improving population health and reducing costs.

The waiver categories and amounts are:

1. Primary Care Expansion - \$1.25 billion
2. Health Home Development - \$525 million
3. New Care Models - \$375 million
4. Vital Access Provider and Safety Net Providers Programs - \$1 billion
5. Public Hospital Innovation - \$1.5 billion
6. Supportive Housing Expansion - \$750 million
7. Long Term Care - \$839 million
8. Capital Stabilization for Hospitals - \$1.7 billion
9. Hospital Transition - \$920 million
10. Workforce - \$500 million
11. Public Health Innovation - \$395 million
12. Regional Health Planning - \$125 million
13. Waiver Evaluation and Program Implementation - \$500 million

NEW REQUEST FOR FUNDING REDUCTION ANNOUNCED BY NEW YORK CITY

As a result of the City's financial plan forecast of a \$2.5 billion gap beginning in FY 14, all City agencies are required to submit spending reduction proposals. The City's November Plan includes a "Program to Eliminate the Gap" (PEG) which requires a reduction in general City support of 5.4% in Fiscal Year 2013 and 8% per year beginning in Fiscal Year 2014. Based on HHC's PEGable base of \$74 million, the Corporation's reduction target is \$4.0 million for Fiscal Year 2013. In Fiscal Year 2014, HHC's PEGable base is \$64 million which increases the targeted reduction to \$5.1 million for that year and beyond.

At this point in time, the Corporation's proposals have not yet been determined. The PEG proposals are due on October 4th, 2013.

NEW EXECUTIVE DIRECTOR TO HEAD MCKINNEY NURSING HOME

I am both sorry and happy to announce the retirement of Peola Small, RN, who served at the Executive Director of Dr. Susan Smith McKinney Nursing and Rehabilitation Center at the end of a long a productive career of 23 years at HHC. Her time at HHC has included stints as Nursing Director at Sea View Hospital as well as Director of Patient Care at McKinney, where she assumed the role of Executive Director in 2006. During her tenure as ED, McKinney has been repeatedly been surveyed successfully by the Commission on Accreditation of Rehabilitation Facilities (CARF) and The Joint Commission. We wish her a long and happy retirement.

While we are sorry to lose Ms. Small's expertise, we are pleased to welcome Mr. Michael Tartaglia as Executive Director. He has an extensive and distinguished career in healthcare, with particular focus on long-term care. He joins us from Greenwich Woods Rehabilitation and Health Care Center, a 217-bed facility, where he served as the Administrator and had oversight of all daily operations. During his tenure there, he oversaw the implementation of innovative programs to better serve patients suffering from Alzheimer's disease, and the facility received the 2010 Bronze Quality Award from the American Health Care Association. Before his time at Greenwich Woods, Mr. Tartaglia served as Administrator of several long-term care facilities in Queens and Long Island, where he directed new construction, initiated fiscal enhancements to increase revenue and revamped internal systems to enhance patient care.

HHC ASKS NEW YORKERS TO "COMMIT TO BE FIT" DURING TAKE CARE NEW YORK MONTH

October is HHC's ninth annual Take Care New York (TCNY) campaign, a public education and awareness campaign designed to persuade NYC residents to seek preventive health screenings at New York City public hospitals and clinics. The campaign focuses on health issues that cause preventable illnesses and deaths in NYC each year, offering flu shots and

screenings for HIV, blood pressure, cancer, asthma, diabetes and other conditions for children and adults that benefit from early detection and treatment.

This year, HHC is challenging New Yorkers to curb obesity, by eating healthier and creating fitness goals for themselves. Participants will receive a triple assessment that includes measuring Body Mass Index (BMI), blood pressure and cardiovascular fitness. At "Commit to Be Fit" stations in HHC facilities in every borough, we will provide those who complete the screenings with an exercise prescription, tips for healthier eating and a pedometer to encourage them to be more active.

HHC IN THE NEWS HIGHLIGHTS

Broadcast

The affordable care act and the uninsured, HHC President Alan Aviles, WABC TV Tiempo, 8/5/12

9/11 Memorial, Jacobi, News12 Bronx, 9/11/12

Art Exchange Program, Lincoln Hospital, Telemundo Ch 47, 7/29/12

Farmers Markets Crop Up at Local Hospitals, North Central Bronx, WABC, 7/27/12

Collaborative In Local Hospitals Helps Doctors Learn To Identify, Treat Sepsis, Dr. Scott Weingart, Elmhurst Hospital Center, NY1, 8/1/12

Texting and Walking, Dr. Livia Santiago, Queens Hospital, Telemundo Ch 47, 7/31/12

New York Officials: Breast Milk May Be Best 'Formula', Dr. Wendy Wilcox, America Trevino, North Central Bronx/Jacobi, NPR, 8/3/12

Youth Cycling Programs Mix Health, Empowerment and Advocacy, Dr. Ed Fishkin, Woodhull, Channel 13, 8/21/12

Free Children's Vaccines Offered At Yankee Stadium Health Fair, Dr. Monique Collier Nickles, Lincoln Hospital, NY1, 8/22/12

Hank Carter: New Yorker of the Week, HHC Coler Goldwater, NY1, 8/17/12

Lincoln Hospital Back to School Immunization Campaign, Dr. Katherine Szema, Lincoln Hospital, News 12 Bronx, 8/21/12

New York City's 'Latch On NYC' initiative seeks to increase breastfeeding, HHC, AirTalk/Southern California Public Radio, 8/1/12

HHC WTC Environmental Health Center

WTC Environmental Health Center continues to enroll hundreds of people, Dr. Sonia Cabrera-Quezada, Bellevue, NY1 Noticias, 9/11/12

Remembering 9/11: WTC Health Center Helping Survivors Heal, Dr. Nomi Levy- Carrick, HHC WTC Environmental Health Center , Fios1news.com, Video, 9/11/12

No terminan de sufrir (They are still suffering), Dr. Sonia Cabrera-Quezada, WTC Environmental Health Center, El Diario, 9/10/12

WTC Environmental Health Center. Dr. Louisa Lam, Gouverneur, Ming Pao, Daily, 9/11/12

WTC Environmental Health Center, Dr. Louisa Lam, Gouverneur, Sing Tao Daily, 9/11/12

WTC Environmental Health Center, Dr. Louisa Lam, Gouverneur, World Journal, 9/11/12

(Also covered by New Tang Dynasty Television, Sino Vison, China Press, Yahoo.com, Sina, China Daily)

Healthcare for 9-11 survivors, Dr. Alfredo Astua, Elmhurst, El Correo, 9/14/12

Healthcare for victims of 9-11 at Elmhurst Hospital in Queens, Dr. Alfredo Astua, Elmhurst, QueensLatino.com, 9/18/12

9/11 illness treatment center exhibits growth and change, 11 years after attacks, Dr. Nomi Levy-Carrick, HHC WTC Environmental Health Center, Downtown Express, 9/5/12

Health Agenda, 9/11 Hope and Healing program, Bellevue Hospital, El Diario, 9/10/12

More News

Sea View center is a Staten Island gem, Sea View, Staten Island Advance, 9/12/12

New hospital unit heals pains, Elmhurst Hospital, Times Ledger, 7/26/12

Hospital unit opens doors, Elmhurst Hospital, Queens Chronicle, 7/26/12

Elmhurst Hospital Center expands emergency room with \$1M treatment area, New York Daily News, 8/2/12

Hospitals Are Worried About Cut in Fund for the Uninsured, HHC, The New York Times, 7/27/12

Imagine a world without AIDS, Dr. Danielle Ofri, Bellevue, The New York Times, 7/30/12
Controlling the Cost of Medicaid, HHC President Alan D. Aviles, Metrofocus.com, 7/30/12

Lincoln receives prestigious Quest for Quality Award, Bronx Free Press, 7/25/12, Dr. Melissa Schori, Lincoln Hospital (Also covered in the Bronx Times,

Patient Centered Care at New York City Health and Hospitals, Lauren Johnston, HHC Chief Nurse Executive, Hartford Institute, July 2012

NYC to Limit Baby Formula in Hospitals, HHC, MedPageToday, 7/31/12

New Kings County Head, Ernest Baptiste, Crain's Health Pulse, 8/2/12

HHC Sees 20% Increase in Number of Uninsured Patients, NY Carib News, 8/1/12

Honored for Decades of Providing Mobility, Hank Carter, HHC, Coler-Goldwater, The Wall Street Journal, 8/7/12

QuadraMed Enables New York City Health & Hospitals Corporation to Attest to Meaningful Use Stage One, Virtual-Strategy Magazine, 8/6/12

It takes a health village, Harlem Hospital, New York Daily News, 8/7/12

N.Y. seeks to tap Medicaid-reform savings, HHC President Alan Aviles, Modern Healthcare, 8/7/12

North General Hospital to be renamed after 'Hank' Carter, HHC, Coler-Goldwater, The New York Amsterdam News, August 9-15, 2012

Henry 'Hank' Carter's Wheelchair Charities coming to East Harlem, HHC, Coler-Goldwater, The New York Amsterdam News, August 9-15, 2012

Henry 'Hank J.' Carter receives the recognition he deserves, HHC, Coler-Goldwater, The New York Amsterdam News, August 16-22, 2012

Gotham Health Approved, HHC, Crain's Health Pulse, 8/13/12

Give and Take: Government, states show flexibility on expansion, HHC Sr. VP LaRay Brown, Queens Hospital Center, Modern Healthcare, 8/11/12

How Five Leading Safety-Net Hospitals Are Preparing For The Challenges And Opportunities Of Health Care Reform, Bellevue Hospital, Health Affairs, August 2012

Local Health Agenda, Lincoln Hospital, Cumberland D&TC, El Diario, 8/20/12

Vacunas son obligatorias antes del regreso a clases en NY, (Vaccines required before going back to school), Dr. Randolph Núñez, Lincoln Hospital, El Diario, 8/20/12

The best stuff on earth - all fresh veggies, Coney Island Hospital, Courier Life's Brooklyn Daily, 8/16/12

Staten Island centenarian celebrates milestone, Sea View Hospital, Staten Island Advance, 8/21/12

Exchange Network Expands, Elmhurst, Queens, Woodhull, MetroPlus, Crain's Health Pulse, 8/21/12

Snakebite in garden a real rattler, Dr. Michael Touger, Jacobi, Lohud.com, 8/21/12

HHC Will Name Healthcare Facility in Harlem after Henry "Hank" J. Carter, Coler-Goldwater, NY Carib News, 8/15/12

Hepatitis C: The Silent Epidemic, Dr. Melissa Schori, Chief Medical Officer, The Bronx Free Press, 8/22/12

Yankees and Lincoln Hospital Immunization, Bronx Times, August 23-29, 2012

Back to School Healthfest, North Central Bronx, New York Daily News, 8/28/12

Isabella and Jayden top baby names in NYC — again!, Coney Island Hospital, New York Daily News, 8/29/12 (Also covered in NY Times, NY Post, CBS/1010 WINS Radio, AmNewYork, Metro.us, WSJ.com, Wfuv.com, NY1, WABC.com, NBC.com, Crain's NY Business, DNAinfo.com, Huffington Post, New York Magazine, The Epoch Times)

Crowley Supports Modernized Medical Record System, Elmhurst, Queens Gazette, 8/29/12

Budget Season Basics for Patient Safety Initiatives, Caroline Jacobs, Mei Kong, HHC, National Patient Safety Magazine, August 28, 2012

Jacobi Medical Center in need of volunteers for new dog therapy program, Bronx Times, 9/2/12

CUNY becomes tobacco free, Harlem, Queens, Elmhurst, The NY Amsterdam News, 9/13/12

Medicare's \$963 Million Experiment, Dr. Ross Wilson, HHC, Bloomberg Businessweek, 9/6/12

At Harlem Hospital, Murals Get a New Life, Harlem, The New York Times, 9/16/12

African American Day Parade Thrills Harlem Onlookers, Sylvia White, Harlem, NY1, 9/16/12

Near the Zoo's Snakes, a Hospital's Collection of Medicine, Dr. Michael Touger, Jacobi, The New York Times, 9/14/12

RESOLUTION

Authorizing the President of the New York City Health and Hospitals Corporation (“the Corporation”) to execute a contract with Epic Systems Corporation for an Enterprise-wide Electronic Medical Record (EMR) System including the software license, installation, training and maintenance to be used throughout the Corporation’s facilities. The contract will be for an initial term of ten years, with an additional five-year renewal option, exercisable solely by the Corporation, in an amount not to exceed \$302,807,986.

WHEREAS, the Corporation desires to implement a completely integrated Electronic Medical Record system with the intent to centralize the clinical functions currently available in eight electronic instances across the Corporation's health care facilities; and

WHEREAS, a qualified EMR vendor is required to assist the Corporation to design, develop and implement an Integrated Clinical Information System that will allow the Corporation’s health care providers to use a single database within a single data repository and help transform the delivery of safe, efficient, and effective care; and

WHEREAS, the Corporation performed an assessment of available market options, leading to the issuance of a Negotiated Acquisition that was released July 16, 2008 in accordance with the Corporation’s operating procedures; and

WHEREAS, a selection committee composed of the Corporation's Central Office and facility representatives considered proposals from nine EMR vendors and recommended that the Corporation enter into a contract with Epic Systems Corporation; and

WHEREAS, the overall responsibility for the monitoring of the contract will be under the direction of the Senior Vice President/Corporate Chief Information Officer;

NOW THEREFORE, BE IT

RESOLVED, that the President of the New York City Health and Hospitals Corporation be and hereby is authorized to execute a contract with Epic Systems Corporation for an Enterprise-wide Electronic Medical Record System including the software license, installation, training and maintenance to be used throughout the Corporation’s facilities. The contract will be for an initial term of ten years, with an additional five-year renewal option, exercisable solely by the Corporation, in an amount not to exceed \$302,807,986, and that the Board’s approval is contingent upon the final determination by the Procurement Review Board, which will be shared with the Board members.

RESOLUTION

Authorizing the President of the New York City Health and Hospitals Corporation (the "Corporation") to execute a requirements contract with Rashel Construction Corporation (the "Contractor") for a cumulative amount not-to-exceed \$5,000,000 to provide construction services for General Construction Work on an as-needed basis at various facilities throughout the Corporation.

WHEREAS, the facilities of the Corporation may require construction services for General Construction Work; and

WHEREAS, the Corporation has determined that the needs of the Networks for these services can be best met by utilizing outside firms, on an as-needed basis through a requirements contract; and

WHEREAS, the Corporation's Operating Procedure No. 100-5 requires approval by the Board of Directors of competitively bid contracts having a bid price greater than \$3,000,000; and

WHEREAS, bids were publicly opened on April 30, 2012 and the Corporation has determined that the Contractor is the lowest responsible bidder for this contract; and

WHEREAS, the Contractor has met all, legal, business and technical requirements and is qualified to perform the services as required in the contract documents.

NOW, THEREFORE, be it

RESOLVED that the President of the New York City Health and Hospitals Corporation (the "Corporation") be and hereby is authorized to execute a contract with Rashel Construction Corporation (the "Contractor") to provide construction services for General Construction Work on an as-needed basis at various facilities throughout the Corporation. The contract shall be for a term of two (2) years, for a cumulative amount not to exceed \$5,000,000 for the services provided by this contractor.

RESOLUTION

Authorizing the President of the New York City Health and Hospitals Corporation (the "Corporation") to execute a requirements contract with Volmar Construction, Inc. (the "Contractor") for a cumulative amount not to exceed \$3,000,000 to provide construction services for Heating Ventilation and Air Conditioning (HVAC) work on an as-needed basis at various facilities throughout the Corporation.

WHEREAS, the facilities of the Corporation may require construction services for General Construction Work; and

WHEREAS, the Corporation has determined that the needs of the Networks for these services can be best met by utilizing outside firms, on an as-needed basis through a requirements contract; and

WHEREAS, the Corporation's Operating Procedure No. 100-5 requires approval by the Board of Directors of competitively bid contracts having a bid price of \$3,000,000 or more; and

WHEREAS, bids were publicly opened on June 6, 2012 and the Corporation has determined that the Contractor is the lowest responsible bidder for this contract; and

WHEREAS, the Contractor has met all, legal, business and technical requirements and is qualified to perform the services as required in the contract documents.

NOW, THEREFORE, be it

RESOLVED that the President of the New York City Health and Hospitals Corporation (the "Corporation") be and hereby is authorized to execute a contract with Volmar Construction, Inc. (the "Contractor") to provide construction services for Heating Ventilation and Air Conditioning (HVAC) work on an as-needed basis at various facilities throughout the Corporation. The contract shall be for a term of two (2) years, for a cumulative amount not to exceed \$3,000,000 for the services provided by this contractor.

RESOLUTION

Authorizing the President of the New York City Health and Hospitals Corporation ("the Corporation") to execute a requirements contract with Atlas Restoration Corporation (the "Contractor") in the amount of \$5,000,000 to provide construction services for General Construction Work on an as-needed basis at various facilities throughout the Corporation.

WHEREAS, the facilities of the Corporation may require construction services for General Construction Work; and

WHEREAS, the Corporation has determined that the needs of the Networks for these services can be best met by utilizing outside firms, on an as-needed basis through a requirements contract; and

WHEREAS, the Corporation's Operating Procedure No. 100-5 requires approval by the Board of Directors of competitively bid contracts having a bid price greater than \$3,000,000; and

WHEREAS, bids were publicly opened on May 1, 2012 and the Corporation has determined that the Contractor is the lowest responsible bidder for this contract; and

WHEREAS, the Contractor has met all, legal, business and technical requirements and is qualified to perform the services as required in the contract documents.

NOW, THEREFORE, be it

RESOLVED that the President of the New York City Health and Hospitals Corporation (the "Corporation") be and hereby is authorized to execute a contract with Atlas Restoration Corporation (the "Contractor") to provide construction services for General Construction Work on an as-needed basis at various facilities throughout the Corporation. The contract shall be for a term of two (2) years, for a cumulative amount not to exceed \$5,000,000 for the services provided by this contractor.

RESOLUTION

Authorizing the President of the New York City Health and Hospitals Corporation (the "Corporation" or "Landlord") to execute a sublease agreement with Meals On Wheels of Staten Island, Inc. (the "Tenant" or "Meals On Wheels"), for the development and operation of a facility housing kitchen, office, and storage functions on the campus of Sea View Hospital Rehabilitation Center and Home (the "Facility").

WHEREAS, Meals On Wheels, a non-profit corporation based in Staten Island, has been delivering hot meals to the borough's frail and elderly since the 1970s; and

WHEREAS, the organization's kitchen currently located on Port Richmond Avenue has limited food preparation capabilities and is no longer able to meet the demand for its services as the meal recipient census grows; and

WHEREAS, locating a new kitchen on the Facility's campus will enable Meals On Wheels to continue to provide its meals to the Staten Island community, and the Facility will benefit from the revenue produced by the sublease; and

WHEREAS, a Public Hearing was held on January 18, 2012, in accordance with the requirements of the Corporation's Enabling Act, and, prior to lease execution, the proposed sublease is subject to the approval of the City Council and the Office of the Mayor.

NOW, THEREFORE, be it

RESOLVED, that the President of the New York City Health and Hospitals Corporation (the "Corporation" or "Landlord") be and hereby is authorized to execute a sublease agreement with Meals On Wheels of Staten Island, Inc. (the "Tenant" or "Meals On Wheels"), for the development and operation of a facility housing kitchen, office, and storage functions on the campus of Sea View Hospital Rehabilitation Center and Home (the "Facility").

The Tenant shall have use and occupancy of an approximately 65,340-square-foot parcel of land located on the northern portion of the Facility's campus ("the Demised Premises"). The Tenant shall develop and operate an approximately 22,400-square-foot facility on the Demised Premises. The balance of the parcel shall be developed for parking use. The initial term of the sublease shall be twenty-five (25) years. The sublease shall contain one 14-year renewal option and one 10-year option exclusive to the Tenant. The base rent for the initial term shall be \$94,740 per year.

The rent during the initial term shall be escalated by three (3) percent per year compounded annually. The rent shall be subject to re-appraisal prior to the commencement of each renewal option.

**Page Two – Resolution
Meals On Wheels – Sea View**

The Tenant shall be responsible for the design, construction, and operation of the residential facility. Design documents shall be subject to review and approval of the Landlord, such approval not to be unreasonably withheld. The tenant has estimated approximately \$4 million for the development of the planned 22,400 square-foot facility.

The Tenant shall be responsible for all interior and exterior structural and non-structural maintenance and repairs to the facility. The cost of all utilities shall be the Tenant's responsibility.

The Tenant shall indemnify and hold harmless the Corporation and the City of New York from any and all claims arising by virtue of its use of the Demised Premises, and shall also provide appropriate insurance naming each as additional insured parties.

RESOLUTION

Authorizing the President of the New York City Health and Hospitals Corporation ("the Corporation" or "Licensor") to execute a revocable license agreement with the Federal Bureau of Investigation of the United States Department of Justice (the "Licensee") for its continued use and occupancy of space to house communications equipment at Coney Island Hospital (the "Facility").

WHEREAS, in July 2007, the Board of Directors authorized the President to enter into a license agreement with the Licensee; and

WHEREAS, the Licensee has operated communications equipment on the Facility's campus since September 2002, and desires to continue operating its system at the site; and

WHEREAS, the Facility continues to have adequate space to accommodate the Licensee's communications equipment; and

WHEREAS, the communications equipment does not compromise Facility operations; and

WHEREAS, the Licensee's communications system complies with applicable federal statutes governing the emission of radio frequency signals and therefore poses no health risk.

NOW, THEREFORE, be it

RESOLVED, that the President of the New York City Health and Hospitals Corporation ("the Corporation" or "Licensor") be and hereby is authorized to execute a revocable license agreement with the Federal Bureau of Investigation of the United States Department of Justice (the "Licensee") for its continued use and occupancy of space to house communications equipment at Coney Island Hospital (the "Facility").

The Licensee shall be granted the continued use and occupancy of approximately 150 square feet of space on the roof of the Main Building and in the 14th floor Mechanical Room (the "Licensed Space") to house its communications equipment. The Licensee shall pay an occupancy fee of approximately \$8,021 per year, with annual increases of 3% per year.

The operation and maintenance of the equipment shall be the responsibility of the Licensee. The occupancy fee shall include the cost of electricity.

The Licensee shall be required to indemnify and hold harmless the Corporation and the City of New York from any and all claims arising out of the use of the "Licensed Space" and shall provide appropriate insurance naming the Corporation and the City of New York as additional insured parties.

The license agreement shall be revocable by either party on ninety (90) days prior notice, and shall not exceed a term of five (5) years without further authorization by the Board of Directors of the New York City Health and Hospitals Corporation. The license agreement shall contain a five-year renewal option, which shall not be exercised without authorization by the Board of Directors.

RESOLUTION

Authorizing the President of the New York City Health and Hospitals Corporation (the "Corporation") to execute a revocable license agreement with Sprint Spectrum L.P. (the "Licensee") for its continued use and occupancy of space for the operation of a cellular communications system at Coler-Goldwater Specialty Hospital and Nursing Facility, Goldwater Campus (the "Facility").

WHEREAS, the Corporation's Board of Directors in October 2006 authorized the execution of a license agreement allowing the Licensee to operate a cellular communications system which by its terms expired November 30, 2011; and

WHEREAS, the Licensee desires to continue operating its communications equipment at the Facility, and the Facility continues to have space suitable for the Licensee's needs; and

WHEREAS, the Licensee's continued use will not compromise Facility operations; and

WHEREAS, the Licensee's cellular communications system is in compliance with applicable federal statutes governing the emission of radiofrequency signals, and therefore poses no health risk.

NOW, THEREFORE, be it

RESOLVED, that the President of the New York City Health and Hospitals Corporation (the "Corporation") be and hereby is authorized to execute a revocable license agreement with Sprint Spectrum L.P. (the "Licensee") for its continued use and occupancy of space for the operation of a cellular communications system at Coler-Goldwater Specialty Hospital and Nursing Facility, Goldwater Campus (the "Facility").

The Licensee shall be granted use and occupancy of a total of approximately 160 square feet of space on the roof and the fourth floor of the Main Building on the Goldwater campus (the "Licensed Space") for the location of cellular antennas and associated equipment. The Licensee will operate a system which includes fourteen (14) antennas. The Licensee shall pay an annual occupancy fee of \$54,170 with a 3% increase on the anniversary of the commencement date for its use and occupancy of the Licensed Space. The Licensee shall be responsible for paying its utility costs.

As a result of the Coler-Goldwater modernization project, the facility's Goldwater campus will be vacated not later than November 2013. Because the Corporation will hold the right to terminate this license on 60 days notice without cause, the Corporation will be able to terminate this license in time to coincide with its closing of the Goldwater campus.

The Licensee shall be required to indemnify and hold harmless the Corporation and the City of New York from any and all claims arising out of its use of the licensed space, and shall provide appropriate insurance naming the Corporation and the City of New York as additional insureds.

The license agreement shall be revocable by either party on sixty (60) days prior notice. The term of this agreement shall not exceed five (5) years without further authorization by the Board of Directors of the Corporation.

RESOLUTION

Authorizing the President of the New York City Health and Hospitals Corporation (the "Corporation") to execute a revocable license agreement with T-Mobile Northeast, LLC, (the "Licensee"), for its use and occupancy of space for the operation of a cellular communications system at Coler-Goldwater Specialty Hospital & Nursing Facility, Coler Campus (the "Facility").

WHEREAS, the Board of Directors approved a resolution on February 29, 2012 to authorize a license agreement with the Licensee for its use and occupancy of space at the Facility for the operation of cellular communications equipment; and

WHEREAS, as a result of a staff clerical error, the resolution provided for payment of an occupancy fee of \$52,840 per year, effective November 1, 2013; and

WHEREAS, the rate that was to have been stated was \$50,807 per year; and

WHEREAS, the Board of Directors desires to adopt an amended resolution to correct the error.

NOW THEREFORE, be it

RESOLVED, that the President of the New York City Health and Hospitals Corporation (the "Corporation") be and hereby is authorized to execute a revocable license agreement with T-Mobile Northeast, LLC, (the "Licensee"), for its use and occupancy of space for the operation of a cellular communications system at Coler-Goldwater Specialty Hospital & Nursing Facility (the "Facility") for the purposes and on the terms approved by the Board of Directors on February 29, 2012 provided that the annual occupancy fee shall be \$50,807 rather than \$52,840 as originally authorized and be it further resolved that the resolution approved on February 29, 2012 is otherwise ratified and confirmed.

RESOLUTION

Approving and ratifying bylaws adopted by HHC ACO Inc.'s Board of Directors, annexed at Exhibit A.

WHEREAS, the Corporation previously authorized the creation of HHC ACO Inc., subject to the Corporation's Board of Directors approving HHC ACO Inc.'s bylaws and any subsequent amendments thereto; and

WHEREAS, HHC ACO Inc.'s Board of Directors previously adopted bylaws of HHC ACO Inc., subject to approval and ratification by the Corporation.

NOW, THEREFORE, BE IT

RESOLVED, THAT THE Corporation hereby approves and ratifies the bylaws adopted by HHC ACO Inc.'s Board of Directors, annexed at Exhibit A.

AMENDED AND RESTATED

BY-LAWS

OF

HHC ACO INC.

Article 1.

Definitions

Section 1.01 Name. The “Corporation” shall mean HHC ACO INC., its successors and assigns.

Section 1.02 Board. The “Board” shall mean the Board of Directors of the Corporation.

Article 2.

Office

Section 2.01 Office. The office of the Corporation shall be located in the County of New York and the State of New York.

Section 2.02 Additional Offices. The Corporation may also have offices at such other places within the State of New York as the Board may from time to time designate or the business of the Corporation may require.

Article 3.

Membership

Section 3.01 Members. The sole Member of the Corporation shall be the New York City Health and Hospitals Corporation.

Section 3.02 Annual Meeting. A meeting of the Member shall be held annually on such date and at such time and place as may be fixed by the Board, and adopted by the Member, for the purpose of electing Directors, receiving annual reports of the Board and Officers, and for the transaction of such other business as may be brought before the meeting.

Section 3.03 Special Meetings. Special meetings of the Member may also be called at any time by the Member’s Chairman, by the Member or a majority of the Member’s Directors then in office, or as otherwise provided by law.

Section 3.04 Place and Time of Meetings. Meetings of the Member may be held at such place and at such time as may be fixed in the notice of the meeting.

Section 3.05 Open Meetings. Meetings of the Member shall be conducted within the requirements of the New York Open Meetings Law (Public Officers Law, Article 7).

Section 3.06 Participation by Videoconference. Unless otherwise prohibited by the New York Open Meetings Law, meetings of the Member may be conducted by means of videoconference communications equipment allowing all persons participating in the meeting to hear and see each other at the same time. Participation by such means shall constitute presence in person at a meeting.

Article 4.

Directors

Section 4.01 Annual Meeting. A meeting of the Board shall be held annually at such place within the State of New York, on such date and at such time as may be fixed by the Board, for the purpose of electing Officers, receiving annual reports of the Board and Officers, and for the transaction of such other business as may be brought before the meeting.

Section 4.02 Number. The number of Directors constituting the entire Board shall be fixed by the Member, but such number shall not be less than three.

Section 4.03 Election and Term of Office. The initial Directors of the Corporation shall be those persons specified in the Certificate of Incorporation of the Corporation. Thereafter, the Directors shall be elected by the Member at the annual meeting or at any regular or special meeting of the Member of the Corporation. Each Director shall hold office until the next annual meeting of the Member and until such Director's successor has been elected and qualified, or until his or her death, resignation or removal.

Section 4.04 Powers and Duties. Subject to the provisions of law, of the Certificate of Incorporation and of these By-Laws, but in furtherance and not in limitation of any rights and powers thereby conferred, the Board shall have the control and management of the affairs and operations of the Corporation and shall exercise all the powers that may be exercised by the Corporation.

Section 4.05 Additional Meetings. Regular meetings of the Board may be held at such times as the Board may from time to time determine. Special meetings of the Board may also be called at any time by the Chairman or by a majority of the Directors then in office.

Section 4.06 Notice of Meetings. Except as otherwise provided by law, including without limitation, the New York Open Meetings Law (Public Officers Law, Article 7), no notice need be given of any annual or regular meeting of the Board. Notice of a special meeting of the Board shall be given by service upon each Director in person or by

mailing the same to him at his or her post office address as it appears upon the books of the Corporation or by facsimile, telegraph, cable, email or other form of recorded communication at least four business days (Saturdays, Sundays and legal holidays not being considered business days for the purpose of these By-Laws) if given by mailing the same, or at least 2 business days if given in person or by any other means of communication, before the date designated for such meeting specifying the place, date and hour of the meeting. Whenever all of the Directors shall have waived notice of any meeting either before or after such meeting, such meeting shall be valid for all purposes. A Director who shall be present at any meeting and who shall not have protested, prior to the meeting or at its commencement, the lack of notice to him, shall be deemed to have waived notice of such meeting. In any case, any acts or proceedings taken at a Directors' meeting not validly called or constituted may be made valid and fully effective by ratification at a subsequent Directors' meeting that is legally and validly called. Except as otherwise provided herein, notice of any Directors' meeting or any waiver thereof need not state the purpose of the meeting, and, at any Directors' meeting duly held as provided in these By-Laws, any business within the legal province and authority of the Board may be transacted.

Section 4.07 Place of Meetings. The Board may hold its meetings within the State of New York.

Section 4.08 Quorum. At any meeting of the Board, a majority of the Directors then in office shall be necessary to constitute a quorum for the transaction of business. However, should a quorum not be present, a majority of the Directors present may adjourn the meeting from time to time to another time and place, without notice other than announcement at such meeting, until a quorum shall be present.

Section 4.09 Voting. At all meetings of the Board, each Director shall have one vote. Except as otherwise provided by the New York Not-For-Profit Corporation Law, the vote of a majority of the Directors present at the time of the vote, if a quorum is present at such time, shall be the act of the Board.

Section 4.10 Action Without a Meeting. Except as otherwise provided by law, including without limitation, the New York Open Meetings Law (Public Officers Law, Article 7), any action required or permitted to be taken by the Board or any committee thereof may be taken without a meeting if all members of the Board or any such committee consent in writing to the adoption of a resolution authorizing the action. The resolution and the written consents thereto by the members of the Board or any such committee shall be filed with the minutes of the proceedings of the Board or such committee.

Section 4.11 Removal. Any Director may be removed for any reason by the Member.

Section 4.12 Resignation. Any Director may resign from office at any time by delivering a resignation in writing to the Board of Directors, and the acceptance of the resignation, unless required by its terms, shall not be necessary to make the resignation effective.

Section 4.13 Vacancies. Any newly created directorships and any vacancy occurring on the Board arising at any time and from any cause may be filled by the Member. A Director elected to fill a vacancy shall hold office for the unexpired term of his or her predecessor.

Section 4.14 Committee. The Board, by resolution adopted by a majority of the entire Board, may designate from among the Directors an executive committee and other standing committees, each consisting of three or more Directors, to serve at the pleasure of the Board, and each of which, to the extent provided in such resolution, shall have the authority of the Board, except as to matters prohibited by Section 712 of the New York Not-For Profit Corporation Law. The Board may designate one or more Directors as alternate members of any such committee, who may replace any absent member or members at any meeting of such committee.

Section 4.15 Participation by Videoconference. Any one or more members of the Board or any committee thereof may participate in a meeting of the Board or such committee by means of a videoconference communications equipment allowing all persons participating in the meeting to hear and see each other at the same time. Participation by such means shall constitute presence in person at a meeting.

Section 4.16 Records. Minutes shall be kept of each meeting of the Board. Copies of the minutes of each such meeting shall be filed with the corporate records.

Article 5.

Officers

Section 5.01 Election and Qualifications; Term of Office. The Officers of the Corporation shall be a Chairman, a Chief Executive Officer, one or more Vice Presidents, a Secretary and a Treasurer. The Officers shall be elected by the Board at the annual meeting or at any regular or special meeting of the Board and each Officer shall hold office for a term of one year and until such Officer's successor has been elected or appointed and qualified, unless such Officer shall have resigned or shall have been removed as provided in Sections 10 and 11 of this Article 5. The same person may hold more than one office, except that the same person may not be both Chief Executive Officer and Secretary. The Board may appoint such other Officers as may be deemed desirable, including one or more other Vice-Presidents, one or more Assistant Secretaries, and one or more Assistant Treasurers. Such Officers shall serve for such period as the Board may designate.

Section 5.02 Vacancies. Any vacancy occurring in any office, whether because of death, resignation or removal, with or without cause, or any other reason, shall be filled by the Board.

Section 5.03 General Powers of the Officers. All Officers as between themselves and the Corporation shall have such authority and perform such duties in the management of

the Corporation as shall be provided in these By-Laws or, to the extent not so provided, by the Board.

Section 5.04 Powers and Duties of the Chairman. The Chairman shall preside at all meetings of the Board at which he or she is present and may call meetings of the Board or any committee when he or she deems necessary. The Chairman shall have such other powers and shall perform such other duties as may from time to time be assigned to the Chairman by the Board.

Section 5.05 Powers and Duties of the Chief Executive Officer. The Chief Executive Officer shall be the chief executive officer of the Corporation and shall from time to time make such reports of the affairs and operations of the Corporation as the Board may direct and shall preside at all meetings of the Board. The Chief Executive Officer shall have such other powers and shall perform such other duties as may from time to time be assigned to the Chief Executive Officer by the Board.

Section 5.06 Powers and Duties of the Vice-Presidents. Each of the Vice-Presidents shall have such powers and shall perform such duties as may from time to time be assigned to such Vice President by the Board.

Section 5.07 Powers and Duties of the Secretary. The Secretary shall record and keep the minutes of all meetings of the Board. The Secretary shall be the custodian of, and shall make or cause to be made the proper entries in, the minute book of the Corporation and such books and records as the Board may direct. The Secretary shall be the custodian of the seal of the Corporation and shall affix such seal to such contracts, instruments and other documents as the Board or any committee thereof may direct. The Secretary shall have such other powers and shall perform such other duties as may from time to time be assigned to the Secretary by the Board.

Section 5.08 Powers and Duties of the Treasurer. The Treasurer shall be the custodian or custodians of all funds and securities of the Corporation. Whenever so directed by the Board, the Treasurer shall render a statement of the cash and other accounts of the Corporation, and the Treasurer shall cause to be entered regularly in the books and records of the Corporation to be kept for such purpose full and accurate accounts of the Corporation's receipts and disbursements. The Treasurer shall at all reasonable times exhibit the books and accounts to any Director upon application at the principal office of the Corporation during business hours. The Treasurer shall have such other powers and shall perform such other duties as may from time to time be assigned to the Treasurer by the Board.

Section 5.09 Delegation. In case of the absence of any Officer of the Corporation, or for any other reason that the Board may deem sufficient, the Board may at any time and from time to time delegate all or any part of the powers or duties of any Officer to any other Officer or to any Director or Directors.

Section 5.10 Removal. Any Officer may be removed from office at any time, with or without cause, by a vote of a majority of the Directors then in office at any meeting of the Board.

Section 5.11 Resignation. Any Officer may resign his or her office at any time, such resignation to be made in writing and to take effect immediately without acceptance by the Corporation.

Section 5.12 Agents and Employees. The Board of Directors may appoint agents and employees who shall have such authority and perform such duties as may be prescribed by the Board of Directors. The Board of Directors may remove any agent or employee at any time with or without cause. Removal without cause shall be without prejudice to such person's contract rights, if any, and the appointment of such persons shall not itself create contract rights.

Section 5.13 Compensation of Officers, Agents and Employees. The Corporation may pay compensation in reasonable amounts to agents and employees for services rendered, such amount to be fixed by the Board of Directors or, if the Board of Directors delegates power to any Officer or Officers, then as approved by such Officer or Officers.

Article 6.

Conflicts Of Interest

Chapter 68 of the Charter of the City of New York defines a "code of ethics" which outlines the standards of conduct governing the relationship between private interests and the proper discharge of official duties of all employees and directors of the New York City Health and Hospitals Corporation, including those who are working for the Corporation or who are directors of the Corporation. Chapter 68 embodies an extensive recitation of acts that constitute conflicts of interest and are thereby prohibited.

The New York City Health and Hospitals Corporation has promulgated its own "Code of Ethics" which outlines the standards of conduct governing the relationship between private interests and the proper discharge of official duties of all personnel who are not covered by Chapter 68. Similar to Chapter 68, the New York City Health and Hospitals Corporation's Code of Ethics embodies an extensive recitation of acts that constitute conflicts of interest and are thereby prohibited. The Corporation has adopted the Code of Ethics with respect to its personnel and Directors who are not subject to Chapter 68.

The Board is committed to recognizing the Corporation's responsibility to organizational ethics and expects, therefore, every employee and Board member to support and adhere to the principles and policies set forth in Chapter 68 and the Code of Ethics.

Article 7.

Bank Accounts, Checks, Contracts and Investments

Section 7.01 Bank Accounts, Checks and Notes. The Board is authorized to select the banks or depositories it deems proper for the funds of the Corporation. The Board shall determine who shall be authorized from time to time on the Corporation's behalf to sign checks, drafts or other orders for the payment of money, acceptances, notes or other evidences of indebtedness.

Section 7.02 Contracts. The Board may authorize any Officer or Officers, agent or agents, in addition to those specified in these By-Laws, to enter into any contract or execute and deliver any instrument in the name of and on behalf of the Corporation, and such authority may be general or confined to specific instances. Unless so authorized by the Board, no Officer, agent or employee shall have any power or authority to bind the Corporation by any contract or engagement or to pledge its credit or render it liable for any purpose or to any amount.

Section 7.03 Investments. The funds of the Corporation may be retained in whole or in part in cash or be invested and reinvested from time to time in such property, real, personal or otherwise, or stocks, bonds or other securities, as the Board may deem desirable.

Article 8.

Miscellaneous

Section 8.01 Documents. There shall be kept at the office of the Corporation correct books of accounts of the activities and transactions of the Corporation, including a minute book, which shall contain a copy of the Certificate of Incorporation, a copy of these By-Laws, and all minutes of meetings of the Board of Directors.

Section 8.02 Fiscal Year. The fiscal year of the Corporation shall be June 30.

Section 8.03 Corporate Seal. The corporate seal shall be circular in form and have inscribed thereon the name of the Corporation, the year of its organization, and the words "Corporate Seal" and "New York". The seal shall be in the charge of the Secretary. If and when so directed by the Board, a duplicate of the seal may be kept and used by the Secretary or the Treasurer. The seal may be used by causing it or a facsimile thereof to be affixed or impressed or reproduced in any other manner.

Article 9.

Dissolution

The Corporation may be dissolved only upon adoption of a plan of dissolution and distribution of assets by the Board that is consistent with the Certificate of Incorporation.

Any nonjudicial dissolution shall be accomplished in accordance with Article 10 of the New York Not-For-Profit Corporation Law or any applicable successor statute or law.

Article 10.

Amendments

These By-Laws may be altered, amended, added to or repealed only by the Member.

Article 11.

Construction

In the case of any conflict between the Certificate of Incorporation of the Corporation and these By-Laws, the Certificate of Incorporation of the Corporation shall control.

RESOLUTION

Approving and ratifying certain actions of the HHC ACO Inc. Board of Directors, which authorized that the number of Directors of HHC ACO Inc.'s Board of Directors be fixed at eight and that each of the following persons be elected to serve as Directors of HHC ACO Inc.'s Board of Directors, subject to such person's earlier death, resignation or removal, in accordance with the laws of the State of New York until such person's successor is duly elected and qualified, and subject to approval and ratification by HHC ACO Inc.'s sole Member, the New York City Health and Hospitals Corporation (the "Corporation") :

Jeroman Berger-Gaskin, a Medicare beneficiary Director;

A Director to be named pursuant to a designation by a majority in number of HHC ACO Inc.'s ACO Participants, as defined in 42 C.F.R. Part 425, other than the Corporation, that have executed Participation Agreements with HHC ACO Inc., and specified in a writing signed by such majority that is delivered to the Chairman of HHC ACO Inc.;

A Director who shall be the Chief Executive Officer of Physician Affiliate Group of New York, P.C. ("PAGNY").

WHEREAS, the Corporation previously appointed certain individuals to serve as the initial Board of Directors of HHC ACO Inc., as specified in the Certificate of Incorporation of HHC ACO Inc., and now wishes to approve and ratify the actions of HHC ACO Inc.'s Board of Directors, which fixed the number of Directors of HHC ACO Inc. at eight and added certain persons as Directors, subject to approval and ratification by the Corporation.

NOW, THEREFORE, BE IT

RESOLVED, THAT THE Corporation hereby approves and ratifies the actions taken by the HHC ACO Inc. Board of Directors, which authorized that the number of Directors of HHC ACO Inc.'s Board of Directors be fixed at eight and that each of the following persons be elected to serve as Directors of HHC ACO Inc.'s Board of Directors, subject to such person's earlier death, resignation or removal, in accordance with the laws of the State of New York until such person's successor is duly elected and qualified, and subject to approval and ratification by HHC ACO Inc.'s sole Member, the Corporation:

Jeroman Berger-Gaskin, a Medicare beneficiary Director;

A Director to be named pursuant to a designation by a majority in number of HHC ACO Inc.'s ACO Participants, as defined in 42 C.F.R. Part 425, other than the Corporation, that have executed Participation Agreements with HHC ACO Inc., and specified in a writing signed by such majority that is delivered to the Chairman of HHC ACO Inc.;

A Director who shall be the Chief Executive Officer of PAGNY.

RESOLUTION

Authorizing the creation of the HHC Finance Corporation (the "Finance Corporation") as a Type C not-for-profit corporation under Section 402 of the New York Not-for-Profit Corporation Law with the New York City Health and Hospitals Corporation (the "Corporation") as its sole member.

WHEREAS, the Corporation wishes to participate in a New Market Tax Credit ("NMTC") supplemental financing of its Harlem Hospital Major Modernization project; and

WHEREAS, NMTC structures often require that, to participate, HHC have an affiliated corporation that is authorized and empowered to take part in a NMTC transaction; and

WHEREAS, it would be useful to form a subsidiary corporation with the power to participate in NMTC structures and take other actions supportive of the Corporation; and

WHEREAS, the Corporation has the right under Section 7385(20) of the HHC Act to form subsidiary corporations.

NOW, THEREFORE, be it

RESOLVED, that the Corporation take the necessary steps to form the HHC Finance Corporation (the "Finance Corporation") as a Type C not-for-profit corporation under Section 402 of the New York Not-for-Profit Corporation Law with the Corporation as its sole member; and it is further

RESOLVED, that the certificate of incorporation for the Finance Corporation be in the form attached hereto; and it is further

RESOLVED, that the initial directors of the Finance Corporation be: Alan D. Aviles, Laray Brown, Antonio Martin, Marlene Zurack and Salvatore Russo and that any subsequent directors elected to fill any vacancies left by the resignation or removal of any of such directors be the successors to such individuals in their offices at the Corporation; and it is further

RESOLVED, that the by-laws of the Finance Corporation be in the form attached hereto.

RESOLUTION

Authorizing: (i) the New York City Health and Hospitals Corporation (the "Corporation") to contribute approximately \$10.661 Million to HHC Finance Corporation (the "Finance Corp") (ii) the directors of the Finance Corp to authorize its use to make a loan of approximately \$10.661 Million to HHC Investment Fund LLC (the "Investment Fund") to be established by U.S. Bancorp Community Development Corporation (the "NMTC Equity Investor"); and (iii) authorizing the President of the Corporation to borrow approximately \$14.7 Million from HHC/NCF Sub-CDE, LLC, a subsidiary of the Investment Fund, for the Corporation's use to pay a work order from the Dormitory Authority of the State of New York ("DASNY") generated for the Harlem Hospital Center major modernization project (the "Project") all in order to effectuate the participation by the Corporation and the Finance Corp in a supplemental financing of the Project through a New Markets Tax Credits structure (the "Proposed Financing"); and (iv) the approval and confirmation of all prior actions previously taken in furtherance of the Proposed Financing.

WHEREAS, HHC Finance Corporation (the "Finance Corp") is a wholly-owned subsidiary of the New York City Health and Hospitals Corporation (the "Corporation"); and

WHEREAS, the Corporation is engaged in a construction project (the "Project") to modernize Harlem Hospital Center ("Harlem Hospital") pursuant to work orders issued to the Dormitory Authority of the State of New York ("DASNY") previously approved by the Corporation's Capital Committee utilizing various sources of funds; and

WHEREAS, the New York City Economic Development Corporation (the "EDC") has proposed to the Finance Corp and to the Corporation a structure by which the Corporation can obtain additional funds for the Project on favorable terms by participating in a financing structure involving New Markets Tax Credits ("NMTC"); and

WHEREAS, the primary source of funding for the Project to date has been The City of New York (the "City"); and

WHEREAS, the structure proposed by the EDC, and its NMTC partner, United Funds Advisors ("UFA"), involves UFA and its subsidiary, National Community Fund I, LLC

("NCF"), providing to the Project a certain allocation of the NMTC credits available from the U.S. Internal Revenue Service to NCF; and

WHEREAS, the structure proposed by the EDC, UFA and NCF involves the contribution of approximately \$10,661,000 by the Corporation to the Finance Corp, and the loan of such amount (the "Leverage Loan") by the Finance Corp to HHC Investment Fund, LLC, an investment fund (the "Investment Fund") to be established by U.S. Bancorp Community Development Corporation (the "NMTC Equity Investor"); and

WHEREAS, the NMTC Equity Investor is expected to make an equity investment of approximately \$4,797,000 in the Investment Fund, and the Investment Fund is expected to invest approximately \$4,339,000 (after the payment of various closing and management expenses), together with the the approximate amount of \$10,661,000 obtained through the Leverage Loan, in HHC/NCF Sub-CDE, LLC, which entity (the "Sub-CDE") constitutes a "qualified community development entity" within the meaning of Section 45D of the Internal Revenue Code of 1986, as amended (the "Code"), and which Section 45D of the Code (the "NMTC Tax Provisions") relates to and governs the NMTC program; and

WHEREAS, the Sub-CDE is then expected to utilize a major portion of such investment made by the Investment Fund in the Sub-CDE to make two loans to the Corporation, one being an "A Loan" in the approximate amount of \$10,661,000 and the other being a "B Loan" in the approximate amount of \$4,039,000 (collectively, the "Project QLICI Loans"); and

WHEREAS, under applicable provisions of the Code, the Corporation and/or a portion of the business of the Corporation consisting of Harlem Hospital Center constitutes a "qualified active low-income community business" (a "QALICB") and the Project constitutes a project eligible for assistance through the NMTC program; and

WHEREAS, the Corporation will use proceeds of the Project QLICI Loans to pay a portion of the costs of the Project; and

WHEREAS, the City will provide funds, directly or indirectly, to reimburse the Corporation for its capital contribution to the Finance Corp; and

WHEREAS, the Corporation will be obligated to pay (or reserve) closing costs and fees, in the approximate amount of \$968,000, from the proceeds of the Project QLICI Loans; and

WHEREAS, after payment of fees and closing costs, the full amount of the approximately \$10,661,000 of proceeds of the A Loan, and a portion of the proceeds of the B Loan equal to approximately \$3,071,000 will be available to pay costs of the Project for Harlem Hospital (including the amount held in the construction debt service reserve); and

WHEREAS, the Investment Fund will be obligated to repay the Finance Corp for the Leverage Loan and the Corporation will be obligated to repay the Sub-CDE for the Project QLICI Loans, in each case upon the terms and conditions set forth in such loan documents consistent with the Summary of Economic Terms attached; and

WHEREAS, pursuant to this Resolution, the Board of Directors of the Corporation will authorize the participation of the Corporation in the NMTC transaction for the benefit of the Project, including the acceptance by the Finance Corp of the funds from the Corporation, the making of the Leverage Loan by the Finance Corp to the Investment Fund and the borrowing of the Project QLICI Loans by the Corporation from the Sub-CDC and has approved the execution and delivery on behalf of the Corporation of the documents necessary, desirable or convenient for the implementation of the NMTC transaction (collectively, the "Proposed Financing");

NOW, THEREFORE, be it

RESOLVED, that the directors of the Finance Corp be and they hereby are authorized to approve the acceptance of the Corporation's contribution of approximately \$10.661 Million and its use to make the Leverage Loan to the Investment Fund; and it is further

RESOLVED, that the President of the Corporation (the "President") be and he hereby is authorized to execute and deliver on behalf of the Corporation, from time to time, any and all documents necessary, desirable or convenient in order to implement the Proposed Financing and any other documents necessary, desirable or convenient in connection therewith. All actions previously taken by the Corporation in connection with the Proposed Financing are approved, authorized, ratified and confirmed. To provide funds to finance the Project, the participation of the Corporation and the Finance Corp in the Proposed Financing is in all respects authorized, approved and confirmed. To finance the Project, the Corporation is authorized to (i) transfer the approximate amount of \$10,661,000 to the Finance Corp; and (ii) borrow the proceeds of the Project QLICI Loans from the Sub-CDE pursuant to one or more Loan Agreements (the "Project Loan Agreements") in accordance with the terms of the Proposed Financing and in conformity with the Summary of Economic Terms attached hereto. And it is further,

RESOLVED, that the execution, delivery and performance of the Project QLICI Loan Agreements by the Corporation and the transactions to be effectuated thereby are in all respects authorized, approved and confirmed. The President is authorized, empowered and directed to execute and/or attest and deliver for and on behalf of the Corporation, as applicable, the Project QLICI Loan Agreements prior to or simultaneously with the implementation of the Proposed Financing, including necessary counterparts, in substantial conformity with the Summary of Economic Terms attached hereto; the execution and/or attestation of the Project QLICI Loan Agreements by him to constitute conclusive evidence of such conformity, and the Project QLICI Loan Agreements with such changes, modifications, additions or deletions shall be binding upon the Corporation; and that from and after the execution and delivery of such documents the foregoing individual is authorized, empowered and directed to do all such acts and things and to execute all such documents as he deems necessary to carry out and comply with the provisions of such documents as executed (the "Basic Agreements").

The President is authorized to agree to, and to execute and to deliver, for and on behalf of the Corporation any and all additional agreements, indentures, escrow agreements, certificates, documents, instruments, opinions, letters and other papers (the "Other Documents") as he, in his sole and absolute discretion, from time to time determines to be necessary, desirable,

advisable or appropriate and in the best interests of the Corporation to implement and carry out the intent and purposes of this Resolution and to complete the Proposed Financing, the execution of such documents to constitute conclusive evidence of such determination and all such changes, modifications, amendments, instruments, certificates, agreements and documents shall be binding on the Corporation as applicable.

The President is authorized, empowered and directed to perform all other acts and to do all other things and to execute and/or attest all such documents for and on behalf of the Corporation as he, in his sole and absolute discretion, from time to time determines to be necessary, desirable, advisable or appropriate and in the best interests of the Corporation to comply with the provisions of the Project QLICI Loan Agreements, the Basic Agreements and the Other Documents as executed and as amended from time to time and to implement and carry out the intent and purposes of this Resolution and to complete the Proposed Financing.

The President is hereby authorized and directed to cause the Corporation and the Finance Corp, as applicable, to perform each and every one of its obligations, undertakings, covenants, commitments, representations and agreements arising under the Project QLICI Loan Agreements and the Leverage Loan Agreement, the Basic Agreements and the Other Documents to which it is a party and all other documents, instruments, agreements and certificates executed and delivered in connection with or under the authority of this Resolution, all as amended from time to time.

Any and all actions taken or contracts entered into heretofore by any officer of the Corporation, on behalf of the Corporation in connection with the Proposed Financing be and the same are hereby ratified, approved and confirmed, and all such actions and contracts are hereby adopted by the Corporation, as applicable, as if each and every act had been done pursuant to the specific authorization of the Corporation.

The provisions of this Resolution shall be separable and if any section, phrase or provision of this Resolution shall for any reason be declared invalid, such declaration shall not affect the validity of the remainder of the sections, phrases or provisions of this Resolution.

The President is hereby authorized and directed to take any action and to execute and deliver any and all documents as may be necessary or desirable to facilitate the purposes of this Resolution. The President may delegate the authority to sign any documents authorized by this Resolution by a written delegation and when given the party so delegated may execute any such documents with the same force and effect as if the President had signed them.

RESOLUTION

Adopting the Corporation's Mission Statement and Performance Measures as required by the Public Authorities Reform Act

WHEREAS, the New York State Public Authorities Reform Act of 2009 requires local public authorities such as the Corporation to adopt each year a mission statement and performance measures to assist the Corporation in determining how well it is carrying out its mission; and

WHEREAS, the Corporation has posted on its website a mission statement that is a refined version of the purposes of the Corporation as expressed in the legislation which created HHC and in the HHC By-Laws; and

WHEREAS, the Corporation keeps extensive data on numerous performance measures for internal monitoring and external reporting; and

WHEREAS, the Corporation has selected performance measures addressing the core functions and values of the Corporation for reporting to the Office of the State Comptroller's Authorities Budget Office (ABO) as required by the Public Authorities Reform Act; and

WHEREAS, the ABO has required reporting of the Corporation's mission and performance measures, as well as responding to certain additional questions, on a form provided by that office and requires that the Board of Directors read and understand the mission statement and read and understand the responses provided to the ABO; and

WHEREAS, the attached "Mission Statement and Performance Measures" is identical to the last report approved by the Board of Directors except that the performance measures have been updated;

NOW, THEREFORE, be it

RESOLVED that the attached "Mission Statement and Performance Measures" as required by the Public Authorities Reform Act is hereby adopted.



Authority Mission Statement and Performance Measurements

Name of Public Authority:

New York City Health and Hospitals Corporation

Public Authority's Mission Statement:

To extend equally to all New Yorkers, regardless of their ability to pay, comprehensive health services of the highest quality in an atmosphere of humane care, dignity and respect:

To promote and protect, as both innovator and advocate, the health, welfare and safety of the people of the City of New York;

To join with other health workers and with communities in a partnership which will enable each of our institutions to promote and protect health in its fullest sense -- the total physical, mental and social well-being of the people.

Date Adopted: September 27, 2012

List of Performance Goals (If additional space is needed, please attach):

	Indicator Name	Indicator Description	FY12
1	General Care Average Length of Stay (days)	Average length of stay for a general care inpatient hospitalization	4.7
2	Uninsured Served	Number of patients without health insurance served by HHC	477,957 (CY11)
3	Total Medicaid Managed Care Enrollment	Total number of individuals served by HHC enrolled in Medicaid managed care	521,434
4	MetroPlus Enrollment	Total number of individuals enrolled in MetroPlus health maintenance plan (Medicaid, Child Health Plus, and Family Health Plus)	420,459
5	Percent of eligible women receiving screening mammograms	Total number of women aged 40 to 70 who received a mammogram screening in the reporting period with a primary care or gynecology visit in the past two years	73.0%
6	Adult Psychiatry Average Length of Stay (days)	Average length of stay for adult psychiatry hospital stays	21.70
7	Total outpatient visits	Total outpatient visits	4,876,259
8	Total emergency room visits	Total emergency room visits	1,190,413
9	HIV connect to care	Percent of diagnosed HIV patients who are linked to care within the month of diagnosis	58.25%

Additional questions:

1. Have the board members acknowledged that they have read and understood the mission of the public authority?

Yes.

2. Who has the power to appoint the management of the public authority?

Pursuant to the legislation that created the New York City Health and Hospitals Corporation, the President is chosen by the members of the Board of Directors from persons other than themselves and serves at the pleasure of the Board. (Unconsolidated Law, section 7394)

3. If the Board appoints management, do you have a policy you follow when appointing the management of the public authority?

The Governance Committee to the Board of Directors, which is a special committee established by the Board, includes the functions of the former Personnel Committee and has, among its responsibilities, the duty to receive, evaluate and report to the Board of Directors with respect to the submissions of appointments of corporate officers.

4. Briefly describe the role of the Board and the role of management in the implementation of the mission.

In addition to standing and special committees which have defined subject matter responsibilities and which meet monthly or quarterly, the Board of Directors meets monthly to fulfill its responsibility as the governing body of HHC and its respective facilities as required by law and regulation by the various regulatory and oversight entities that oversee HHC. Corporate by-laws and established policies outline the Board's participation in the oversight of the functions designated to management in order to ensure that HHC can achieve its mission in a legally compliant and fiscally responsible manner.

5. Has the Board acknowledged that they have read and understood the responses to each of these questions?

Yes.

RESOLUTION

Authorizing the President of the New York City Health and Hospitals Corporation (the "Corporation") to name the Burn Intensive Care Unit on the second floor of Building 6 at Jacobi Medical Center (the "Facility") "The Stanley M. Levenson, M.D. Burn Intensive Care Unit".

WHEREAS, the Facility has requested that the Burn Intensive Care Unit on the second floor of Building 6 (the new inpatient building) be named in honor of Stanley M. Levenson, M.D., who, as the Founding Director of the Burn Intensive Care Unit at the Facility, provided leadership for almost a quarter of a century and who was a nationally recognized leader, educator, researcher and innovator in the care of burns and other wounds and in nutrition for wound healing; and

WHEREAS, Dr. Levenson, during his more than 35 year career at the Facility, used his expertise to develop the Burn Intensive Care Unit into a first-rate clinical center that successfully treated hundreds of burn victims and trained scores of physicians in the latest treatment protocols for the care of burns and other wounds; and

WHEREAS, the Facility, in conjunction with the naming of the Burn Intensive Care Unit and based on Dr. Levenson's work, will develop educational materials on burn and wound care that will be available for patients, their families and visitors; and

WHEREAS, Dr. Levenson's family and colleagues, in conjunction with the naming of the Burn Intensive Care Unit, have expressed an interest in raising funds for the support of the Unit and the Facility's educational efforts around burn and wound care; and

WHEREAS, the Facility has met the requirements for naming a portion of a facility as set forth in the Corporation's Operating Procedure 100-8 dated December 15, 2004 including that no person or persons on behalf of the Corporation or the Facility solicited a gift and that the naming is supported by the Facility's Community Advisory Board, the Medical Board, and the Executive Director; and

WHEREAS, the request has been submitted to the President advising of the intent to name the Burn Intensive Care Unit after Dr. Levenson.

NOW, THEREFORE, be it

RESOLVED, that the President of the New York City Health and Hospitals Corporation (the "Corporation") be and is hereby authorized to name the Burn Intensive Care Unit on the second floor of Building 6 at Jacobi Medical Center (the "Facility") "The Stanley M. Levenson, M.D. Burn Intensive Care Unit".

The President of the Health and Hospitals Corporation is hereby authorized to notify all private parties and public agencies and organizations involved and interested in the affairs of such naming.

RESOLUTION

Authorizing the President of the New York City Health and Hospitals Corporation (the "Corporation") to modify the scope and budget for the Major Modernization project at Gouverneur Healthcare Services (the "Facility") to add an additional \$38.2 million, raising the total project budget to \$247.479 million.

WHEREAS, the Major Modernization project at Gouverneur Healthcare Services was first authorized by Capital Committee approval of a Work Order for the Dormitory Authority of New York ("DASNY") on January 13, 2005; and

WHEREAS, subsequent DASNY Work Orders for the project were presented to Capital Committee on 2/9/2006, 9/10/2007, 4/10/2008, 6/12/2008, 2/12/2009, 6/11/2009, 10/23/2009, 3/11/2010, and 6/2/2011 which together authorized the total expenditure on the project of \$207.1 million; and

WHEREAS, scope changes and other revisions to the project budget have been proposed to address field conditions, changes in regulatory requirements, code violation corrections, and design enhancement; and

WHEREAS, the additional work proposed to be performed will require addition to the project budget of \$38.2 Million; and

WHEREAS, funding of \$1.3 million was reallocated from other available current capital project balances, and \$0.5 million from fiscal year 2013 Section 254 appropriations was added to the project's capital plan via the fiscal year 2013 September Plan submission; and

WHEREAS, funding in the amount of \$207.1 million was appropriated in the Corporation's City Capital Commitment Plan and an additional request of \$36.4million has been made via the Fiscal Year 2013 September Plan submission; and

WHEREAS, therecentrevision to Operating Procedure 100-5 requires construction project budgets of \$3 million or more to receive Board of Directors approval;

WHEREAS, the proposed modification of the project budget exceeds \$3 Million; and

WHEREAS, past practice has been to submit construction work orders for construction projects managed by DASNY or EDC through the Capital Committee and not to submit construction projects to the full Board of Directors at all; and

WHEREAS, it would be redundant to seek secure approval by the Board of Directors of this resolution and to also seek the Capital Committee's approval of work orders for the proposed additional work and cost.

NOW THEREFORE, be it

RESOLVED, that the President of the New York City Health and Hospitals Corporation, be and he hereby is authorized to modify the scope and funding for the Major Modernization project at Gouverneur Healthcare Services in accordance with the budget attached at an additional cost of \$38 million, raising the total project budget to \$247.479 million; and

RESOLVED, this Resolution shall stand in lieu of an approval by the Capital Committee of any work order for the expenditure approved by this Resolution.

RESOLUTION

Authorizing the President of the New York City Health and Hospitals Corporation (the "Corporation") to modify the Capital budget for the Lincoln Medical and Mental Health Center Emergency Room Expansion and Annex by \$9 million, increasing the total project budget to \$37.3 million.

WHEREAS, the Lincoln Emergency Room Expansion Project and Annex was developed as a two-phase project; and

WHEREAS, the Annex phase of the project has been completed at a cost of \$15,270,000; and

WHEREAS, the two phase project was budgeted for \$28,275,000 million in Capital funds; and

WHEREAS, the second phase of the project, encompassing expansion of the Emergency Department requires the use of \$9 million in additional Capital funding to replace OTPS funds initially identified to fund the project; and

WHEREAS, funding for the additional cost of the project will be provided by reallocating capital funds from other HHC projects; and

WHEREAS, the revision to Operating Procedure 100-5 requires that construction projects with budgets of \$3 million or more receive approval of the Board of Directors not just the approval of work orders through the Capital Committee as had previously been the case; and

WHEREAS, the proposed expansion to the total project budget will exceed \$3 Million; and

WHEREAS, it would be redundant to seek approval for both work orders and total project budgets.

NOW THEREFORE, be it

RESOLVED, that the President of the New York City Health and Hospitals Corporation (the "Corporation"), be and he hereby is authorized to modify the funding for the Emergency Department Renovation and Expansion project at Lincoln Hospital in accordance with the budget attached at an additional cost of \$9 million, raising the total project budget to \$37.3 million.

RESOLVED, that the approval of this resolution shall be in lieu of an approval by the Capital Committee of a Work Order for the funds authorized in this resolution.

Resolution

Authorizing the President of the New York City Health and Hospitals Corporation (“the Corporation”) to negotiate and execute a renewal and amendment to the contract with SunGard Availability Services (SunGard) for an alternate data center for disaster recovery, business continuity and associated professional services. Funding for the four-year renewal term per the Corporation’s exercise of its renewal options under the existing contract is \$5,321,880 annually, for a total amount not to exceed \$25,550,000 which includes a 20% contingency of \$4,262,480.

WHEREAS, the Corporation currently uses SunGard as its alternate data center under an existing contract originally awarded via a Greater New York Hospital Association (GNYHA) contract; and

WHEREAS, SunGard has hosted mission critical servers and computer systems and has provided customized solutions for the Corporation for the last five years without any service interruption; and

WHEREAS, given the anticipated costs of building a replacement alternate data center with a new vendor and migrating off the current alternate data center to a new facility, and the need for additional power for new Information Technology capital projects including the Electronic Medical Record (EMR), renewing the SunGard contract is in the best interests of the Corporation; and

WHEREAS, the contract will be managed and monitored under the direction of the Senior Vice President/ Corporate Chief Information Officer.

NOW, THEREFORE, be it:

RESOLVED, THAT THE President of New York City Health and Hospitals Corporation be and hereby is authorized negotiate and execute a renewal and amendment to the contract with SunGard Availability Services (SunGard) for an alternate data center for disaster recovery, business continuity and associated professional services. Funding for the four-year renewal term per the Corporation’s exercise of its renewal options under the existing contract is \$5,321,880 annually, for a total amount not to exceed \$25,550,000 which includes a 20% contingency of \$4,262,480.

**Executive Summary –
Alternate Data Center (Business Continuity/Disaster Recovery)**

The accompanying resolution requests approval to negotiate and execute a renewal and amendment to the contract with SunGard Availability Services (SunGard) for an alternate data center for disaster recovery and business continuity including cabinet space, caged cabinets, power, cabling, and professional services. Funding for the four-year renewal term per the Corporation's exercise of its renewal options under the existing contract is \$5,321,880 annually, for a total amount not to exceed \$25,550,000 which includes a 20% contingency of \$4,262,480. The contingency is needed if the Corporation requires additional power and space to support growth, and in the event of an emergency, to enable the Corporation to secure managed services for disaster recovery.

The Corporation currently uses SunGard as its alternate data center under an existing contract originally awarded via a Greater New York Hospital Association (GNYHA) contract. SunGard hosts mission critical servers and computer systems for the Corporation. It is a Tier 4 Backup Data Center. Data center tier standards measure the quality and reliability of a data center's server hosting ability. Tier 4 data centers are considered the most robust and are less prone to failures. SunGard has provided customized solutions for the Corporation for the last five years without any service interruption.

The proposed pricing under the new contract is approximately 20% less than the annual costs that the Corporation currently pays SunGard. The proposed contract includes 193kW of power needed for the Electronic Medical Record (EMR) and new IT Capital Projects for the Corporation. After factoring the cost of the additional power, the Corporation will save approximately \$20.28 million under the new contract. Furthermore, this contract includes additional savings of approximately \$71,800 per month, *if additional* power is needed when compared to the current contract rate. These additional savings are for additional blocks of 100kW of power.

It will cost approximately \$43 million to build a replacement data center and migrate the current data center to a new facility. Such a migration would take between eighteen months to two years to complete. The cost to migrate to another existing data center site versus building a new data center would be approximately \$26 million. Not securing a contract with the existing back up site data center would also present a potential financial risk up to \$60 million in lost Federal incentives stemming from the Electronic Medical Record program.

Due to the cost to build a replacement Tier 4 Backup Data Center, the cost to migrate off the current SunGard Tier 4 Backup Data Center to a new facility, and the need for additional power for new Information Technology capital projects including the Electronic Medical Record (EMR), renewing the SunGard contract is in the best interests of the Corporation.

CONTRACT FACT SHEET
New York City Health and Hospitals Corporation

Contract Title: SunGard Disaster Recovery Data Center
Project Title & Number: Alternate Data Center (Business Continuity/Disaster Recovery)
Project Location: SunGard Data Center, New Jersey
Requesting Dept.: Enterprise IT Services
Number of Respondents: Renewal
(If Sole Source, explain in Background section)

Successful Respondent: SunGard Availability Services

Contract Term: 4 Year Contract Term

Contract Amount: \$5,321,880 annually for a total amount not to exceed \$25,550,000
which includes a 20% contingency of \$4,262,480

Number of Respondents: Renewal
(If Sole Source, explain in Background section)

Range of Proposals: \$ _____ to \$ _____

Minority Business Enterprise Invited: Yes If no, please explain: Renewal

Funding Source: X General Care Grant: explain _____
Capital _____
Other: explain _____

Method of Payment: Lump Sum Per Diem Time and Rate
Other: explain Monthly Payments

EEO Analysis: Conditionally Approved; SunGard has been requested to appear before the 10/16/12 EEO Committee

Compliance with HHC's McBride Principles? Yes No

Vendex Clearance Yes No N/A (Pending)

(Required for contracts in the amount of \$100,000 or more awarded pursuant to an RFP, NA or as a Sole Source, or \$100,000 or more if awarded pursuant to an RFB.)

CONTRACT FACT SHEET (continued)

Background (include description and history of problem; previous attempts, if any, to solve it; and how this contract will solve it):

The Corporation utilizes SunGard Availability Services as an alternate data center to backup and replicate applications, data and services which reside at the Jacobi Data Center in the Bronx. The Corporation currently uses SunGard under an existing contract that was originally awarded via a Greater New York Hospital Association (GNYHA) contract. The Corporation's contract with SunGard expires on October 31, 2012. The accompanying resolution requests approval to negotiate and execute a renewal and amendment to the contract. Funding for the four-year renewal term per the Corporation's exercise of its renewal options under the existing contract is \$5,321,880 annually for a total amount not to exceed \$25,550,000 which includes a 20% contingency of \$4,262,480.

Enterprise Information Technology Services (EITS) estimates it will take between eighteen months to two years to complete a move from the SunGard Data Center to a new data center and cost approximately \$43 million to build a replacement data center and migrate the current data center to a new facility. The cost to migrate to another existing data center site versus building a new data center would be approximately \$26 million. It also would present a potential financial risk of up to \$60 million in lost Federal incentives stemming from the Electronic Medical Record program.

SunGard provides space, power and environmentals to the Corporation. SunGard provides disaster recovery services, managed IT services and information availability consulting services. In addition, SunGard assists the Corporation with conducting annual disaster recovery mainframe planning and testing

SunGard has provided customized solutions for the Corporation for the last five years without any service interruption.

Contract Review Committee

Was the proposed contract presented at the Contract Review Committee (CRC)? (include date):

September 19, 2012

Has the proposed contract's scope of work, timetable, budget, contract deliverables or accountable person changed since presentation to the CRC? If so, please indicate how the proposed contract differs since presentation to the CRC:

N/A.

Selection Process (attach list of selection committee members, list of firms responding to RFP or NA, list of firms considered, describe here the process used to select the proposed contractor, the selection criteria, and the justification for the selection):

Not Applicable. This is a renewal of an existing contract.

Scope of work and timetable:

SunGard provides space, power and environmental services to the Corporation. The contract scope includes cabinet space, caged cabinets, power, cabling, and professional services. SunGard also provides disaster recovery services, managed IT services and information availability consulting services. In addition, SunGard assists the Corporation with conducting annual disaster recovery mainframe planning and testing. Costs are billed monthly.

The current contract with SunGard expires on October 31, 2012. Following approval of this renewal and amendment from the Contract Review Committee and the Board of Directors, the anticipated start date of the renewal is November 1, 2012.

Provide a brief costs/benefits analysis of the services to be purchased.

Enterprise Information Technology Services (EITS) estimates it will take between eighteen months to two years to complete a move from the SunGard Data Center to a new data center and cost approximately \$43 million to build a replacement data center and migrate the current data center to a new facility. The cost to migrate to another existing data center site versus building a new data center would be approximately \$26 million. It also would present a potential financial risk of up to \$60 million in lost Federal incentives stemming from the Electronic Medical Records program.

In addition, the proposed pricing under the new contract is approximately 20% less than the current annual costs that the Corporation pays SunGard. As illustrated in the table below, the Corporation currently pays SunGard approximately \$6.65 million an annual basis. This annual cost will decrease to approximately \$5.32 million under the new contract, and also includes an additional 193kW of power needed for the Electronic Medical Record (EMR) and new IT Capital Projects for the Corporation.

If Corporation were to pay SunGard for the additional 193kW of power at the current contract rates, the annual contract cost to the Corporation would increase to \$10.39 million a year. This represents savings of over \$5.07 million a year ($\$10.39 \text{ million} - \$5.32 \text{ million} = \$5.07 \text{ million}$). Over the course of the four year contract term, this totals \$20.28 million in savings ($\$5.07 \text{ million} \times 4 \text{ years} = \20.28 million).

This contract includes additional savings of approximately \$71,800 per month, if additional power is needed when compared to the current contract rate. These additional savings are for additional blocks of 100kW of power.

Table: Costs/Savings Analysis of the Services

Cost Analysis	NO Power Increase	With Capital Project and EMR Power Increases		
	Current Contract Rate	Using SunGard Current Contract Rate (A)	Using SunGard Proposed New Contract (B)	Savings (C = A - B)
Usage	343	536	536	
Cost per kW	\$1,616	\$1,616	\$827	\$788
Monthly Cost	\$554,230	\$866,085	\$443,490	\$422,595
Annual Cost	\$6,650,760	\$10,393,024	\$5,321,880	\$5,071,144
Cost Over 4 Years	\$26,603,040	\$41,572,097.49	\$21,287,520	\$20,284,577.49

Cost Analysis	Additional Blocks of 100kW Power BEYOND 536kW		Additional Savings	
	Using SunGard Current Contract Rate	Using SunGard Proposed New Contract	Additional Blocks of 100kW @ \$898 Per kW Versus Current Rate (Per Month, IF NEEDED)	\$71,783
	= \$1,616 * 100kW	= \$898 * 100kW		
	\$161,600	\$89,800		

Provide a brief summary of historical expenditure(s) for this service, if applicable.

FY09: \$5,176,454
 FY10: \$5,700,092
 FY11: \$6,075,505
 FY12: \$7,277,256*

The above amounts represent cash expenditures.

*Includes consulting services for a Risk Assessment and Business Impact Analysis.

Provide a brief summary as to why the work or services cannot be performed by the Corporation's staff.

This contract submission is for the Tier 4 Backup Data Center for the Jacobi Data Center. Data center tier standards exist to measure the quality and reliability of a data center's server hosting ability. The Uptime Institute uses a 4-Tier ranking system as a benchmark to determining the dependability of a data center.

Tier 4 data centers are considered the most robust and are less prone to failures. They are designed to host mission critical servers and computer systems, with fully redundant subsystems (cooling, power, network links and storage) and compartmentalized security zones controlled by biometric access controls methods. All cooling equipment is independently dual-

powered, including chillers and heating, ventilating and air-conditioning (HVAC) systems guaranteeing 99.995% availability.

HHC currently does not have the ability to provide for this internally.

Will the contract produce artistic/creative/intellectual property? Who will own it? Will a copyright be obtained? Will it be marketable? Did the presence of such property and ownership thereof enter into contract price negotiations?

No artistic/creative/intellectual property will be produced from this contract. All data stored at the SunGard facility will be owned by HHC and secured by SunGard using HHC requirements. All installed equipment at the SunGard facility will be owned by HHC.

Contract monitoring (include which Senior Vice President is responsible):

Bert Robles
Senior Vice President/Corporate Chief Information Officer

Equal Employment Opportunity Analysis (include outreach efforts to MBE/WBE's, selection process, comparison of vendor/contractor EEO profile to EEO criteria. Indicate areas of under-representation and plan/timetable to address problem areas):

Received By E.E.O. August 2012

Analysis Completed By E.E.O. 9/17/12

Manasses Williams
Name

SunGard received EEO approval for its Carlstadt, NJ location, which is where the Corporation's data center is located. SunGard received a conditional approval for it Wayne, PA location. SunGard has been requested to appear before the EEO Committee on October 16, 2012.

Manasses C. Williams
Assistant Vice President
Affirmative Action/EEO
manasses.williams@nychhc.org

TO: Afshan Syed
Office of Information Services (CIS)

FROM: Manasses C. Williams 

DATE: September 17, 2012

SUBJECT: EEO CONTRACT COMPLIANCE REVIEW AND EVALUATION

The proposed contractor/consultant, Sungard Availability Services, LP, has submitted to the Affirmative Action Office a completed Contract Compliance Questionnaire and the appropriate EEO documents.

This company is a:

Minority Business Enterprise Woman Business Enterprise Non-M/WBE

Project Location(s): Central Office

Contract Number: _____

Project: Alternate Data Center

Submitted by: Office of Information Services

EEO STATUS:

1. Approved
2. Approved with follow-up review and monitoring
3. Not approved
4. Subject to EEO Committee Review

COMMENTS:

MCW:srf

SunGard Disaster Recovery/Business Continuity Alternate Data Center

Presentation Summary- October 11, 2012

The Corporation currently uses SunGard as its alternate data center under an existing contract originally awarded via a Greater New York Hospital Association (GNYHA) contract. SunGard hosts mission critical servers and computer systems for the Corporation. It is a Tier 4 Backup Data Center. Data center tier standards measure the quality and reliability of a data center's server hosting ability. Tier 4 data centers are considered the most robust and are less prone to failures. SunGard has provided customized solutions for the Corporation for the last five years without any service interruption.

It will cost approximately \$43 million to build a replacement data center and migrate the current data center to a new facility. Such a migration would take between eighteen months to two years to complete. The cost to migrate to another existing data center site versus building a new data center would be approximately \$26 million. Not securing a contract with the existing back up site data center would also present a potential financial risk up to \$60 million in lost Federal incentives stemming from the Electronic Medical Record program.

Due to the cost to build a replacement Tier 4 Backup Data Center, the cost to migrate off the current SunGard Tier 4 Backup Data Center to a new facility, and the need for additional power for new Information Technology capital projects including the Electronic Medical Record (EMR), renewing the SunGard contract is in the best interests of the Corporation.

This presentation and the accompanying resolution requests approval to negotiate and execute a renewal and amendment to the contract with SunGard Availability Services (SunGard) for an alternate data center for disaster recovery and business continuity including cabinet space, caged cabinets, power, cabling, and professional services. Funding for the four-year renewal term per the Corporation's exercise of its renewal options under the existing contract is \$5,321,880 annually, for a total amount not to exceed \$25,550,000 which includes a 20% contingency of \$4,262,480.

The contingency is needed if the Corporation requires additional power and space to support growth, and in the event of an emergency, to enable the Corporation to secure managed services for disaster recovery.



SunGard Disaster Recovery / Business Continuity
Alternate Data Center

Bert Robles, SVP/Corporate CIO

Corey K. Cush, AVP

October 11, 2012

EXECUTIVE SUMMARY



A data center or computer center(also datacenter) is a facility used to house computer systems and associated components, such as telecommunications, servers, networking equipment and storage systems. It generally includes redundant or backup power supplies, redundant data communications connections, environmental controls (e.g., air conditioning, fire suppression) and security devices.

The most stringent level is a Tier 4 data center, which is designed to host mission critical computer systems, with fully redundant subsystems and compartmentalized security zones controlled by biometric access controls methods.

Tier Level	Requirements
1	<ul style="list-style-type: none">• Single non-redundant distribution path serving the IT equipment• Non-redundant capacity components• Basic site infrastructure with expected availability of 99.671%
2	<ul style="list-style-type: none">• Meets or exceeds all Tier 1 requirements• Redundant site infrastructure capacity components with expected availability of 99.741%
3	<ul style="list-style-type: none">• Meets or exceeds all Tier 1 and Tier 2 requirements• Multiple independent distribution paths serving the IT equipment• All IT equipment must be dual-powered and fully compatible with the topology of a site's architecture• Concurrently maintainable site infrastructure with expected availability of 99.982%
4	<ul style="list-style-type: none">• Meets or exceeds all Tier 1, Tier 2 and Tier 3 requirements• All cooling equipment is independently dual-powered, including chillers and heating, ventilating and air-conditioning (HVAC) systems• Fault-tolerant site infrastructure with electrical power storage and distribution facilities with expected availability of 99.995%

EXECUTIVE SUMMARY



A data center or computer center(also datacenter) is a facility used to house computer systems and associated components, such as telecommunications, servers, networking equipment and storage systems. It generally includes redundant or backup power supplies, redundant data communications connections, environmental controls (e.g., air conditioning, fire suppression) and security devices.

The most stringent level is a Tier 4 data center, which is designed to host mission critical computer systems, with fully redundant subsystems and compartmentalized security zones controlled by biometric access controls methods.

Tier Level	Requirements
1	<ul style="list-style-type: none">• Single non-redundant distribution path serving the IT equipment• Non-redundant capacity components• Basic site infrastructure with expected availability of 99.671%
2	<ul style="list-style-type: none">• Meets or exceeds all Tier 1 requirements• Redundant site infrastructure capacity components with expected availability of 99.741%
3	<ul style="list-style-type: none">• Meets or exceeds all Tier 1 and Tier 2 requirements• Multiple independent distribution paths serving the IT equipment• All IT equipment must be dual-powered and fully compatible with the topology of a site's architecture• Concurrently maintainable site infrastructure with expected availability of 99.982%
4	<ul style="list-style-type: none">• Meets or exceeds all Tier 1, Tier 2 and Tier 3 requirements• All cooling equipment is independently dual-powered, including chillers and heating, ventilating and air-conditioning (HVAC) systems• Fault-tolerant site infrastructure with electrical power storage and distribution facilities with expected availability of 99.995%

Existing SunGard Availability Services

Normal operation: Application Servers communicate with primary databases at CDC

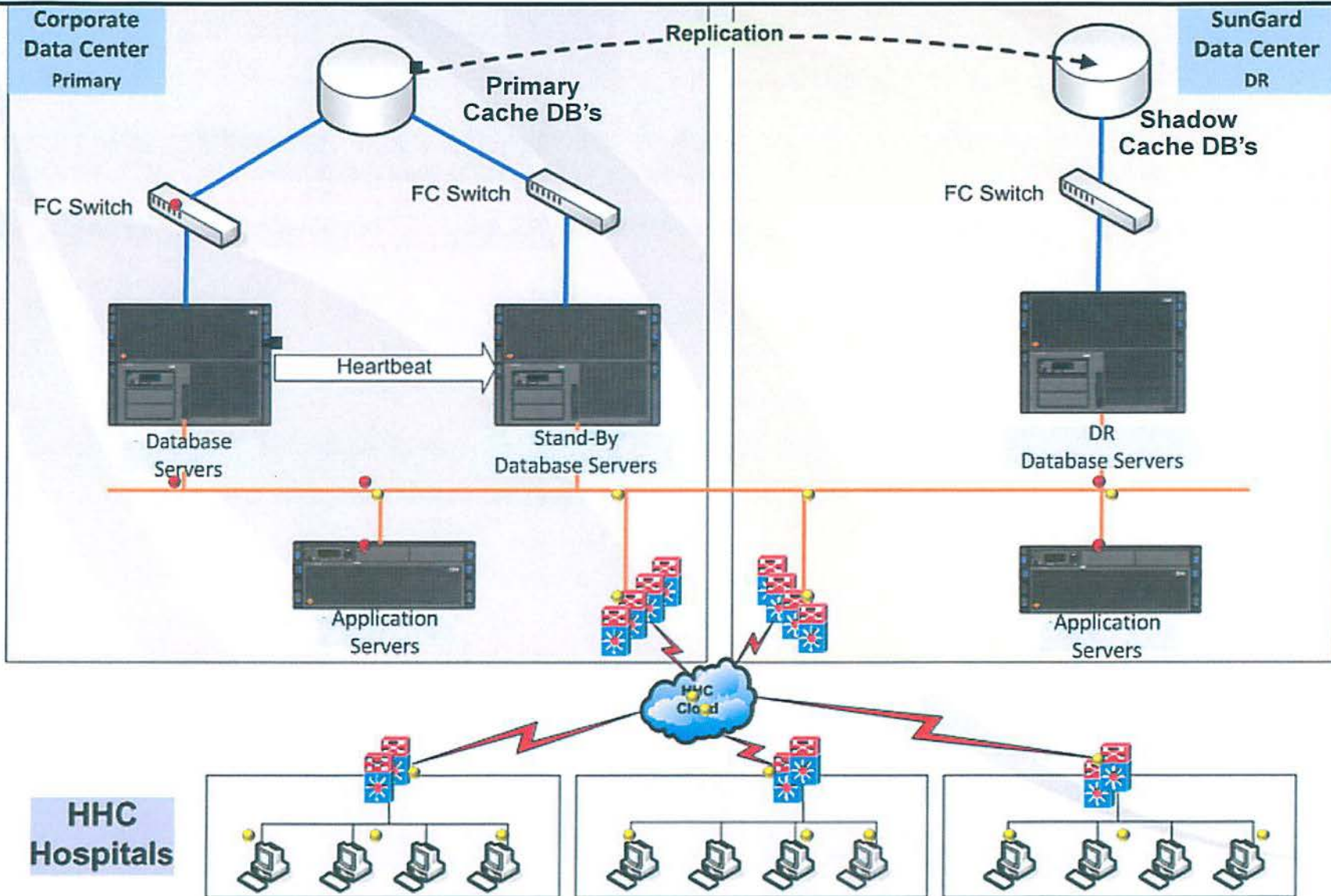

Existing SunGard Availability Services

Primary DB down: Application Servers communicate with secondary database servers at CDC

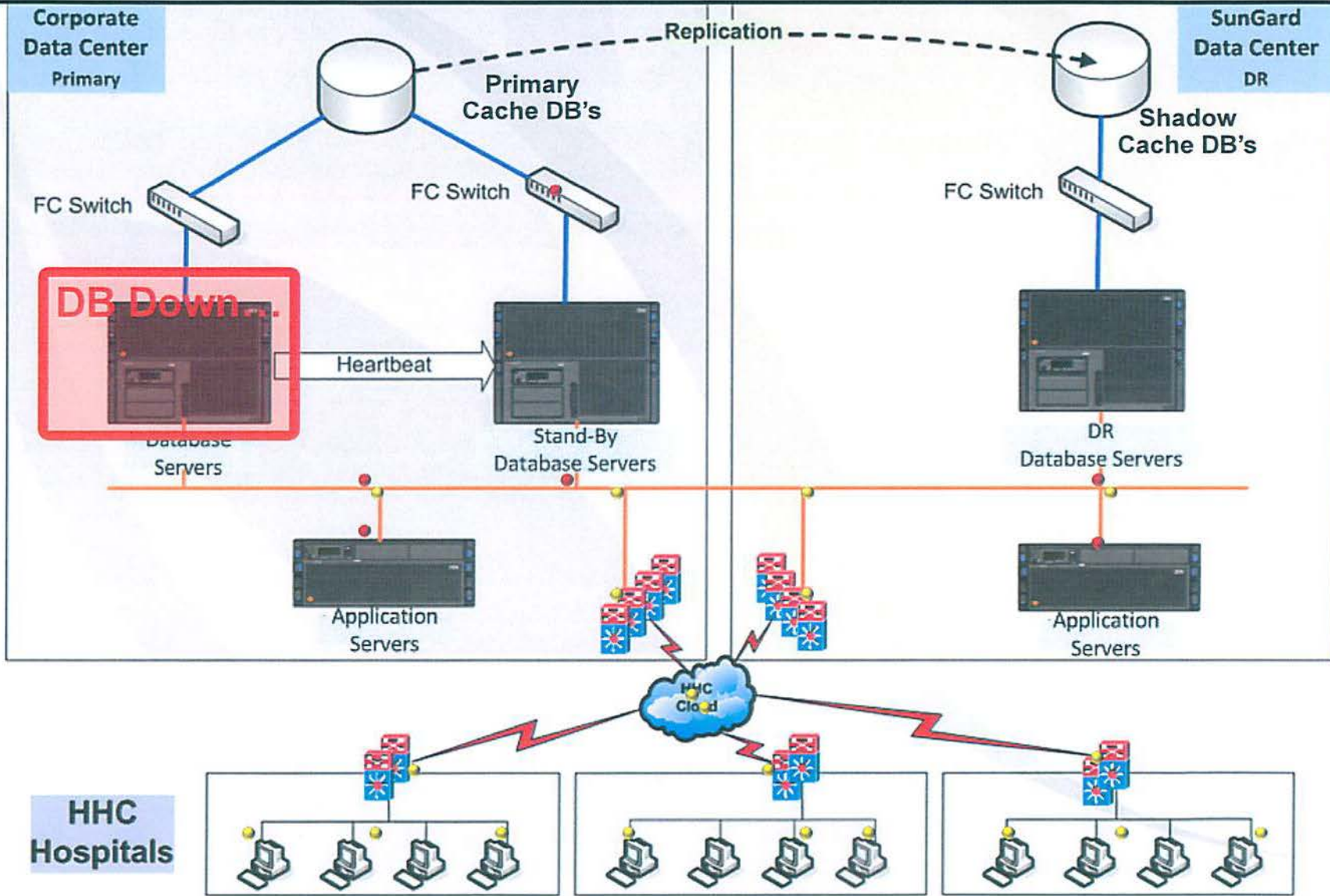

Existing SunGard Availability Services

CDC down: Application Servers communicate with DR databases at SDC

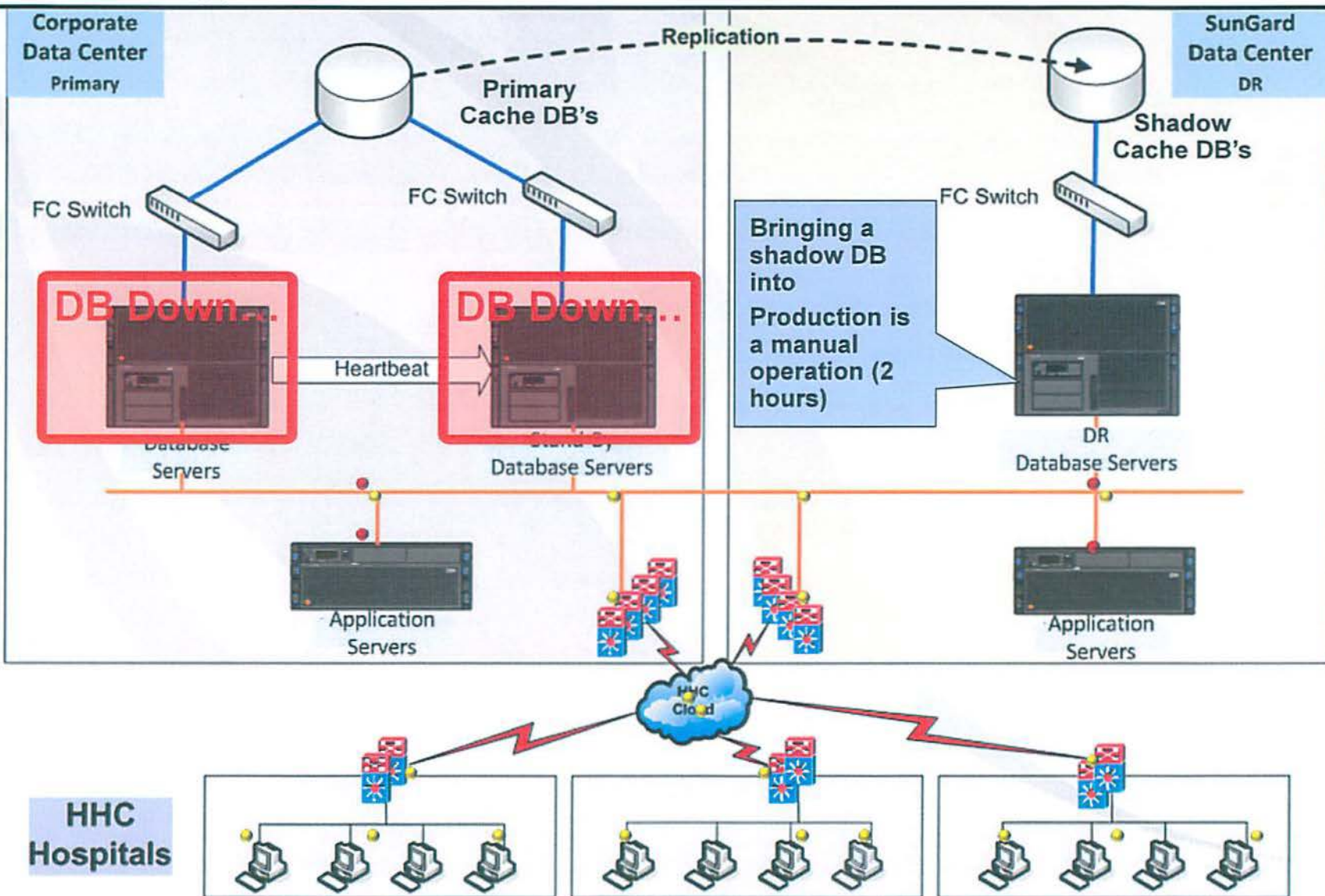

SunGard Contract Information



- Current contract rate is \$6.7 million annually
- Proposed contract rate is \$5.3 million annually includes additional power

Cost Analysis	NO Power Increase	With Capital Project and EMR Power Increases		Savings (C = A - B)
	Current Contract Rate	Using SunGard Current Contract Rate (A)	Using SunGard Proposed New Contract (B)	
Usage	343	536	536	
Cost per KW	\$1,616	\$1,616	\$827	\$788
Monthly Cost	\$554,230	\$866,085	\$443,490	\$422,595
Annual Cost	\$6,650,760	\$10,393,024	\$5,321,000	\$5,071,144
Cost Over 4 Years	\$26,603,040	\$41,572,097.49	\$21,287,520	\$20,284,577.49

Cost Analysis	Additional Blocks of 100kW Power BEYOND 536kW		Additional Savings	
	Using SunGard Current Contract Rate	Using SunGard Proposed New Contract	Additional Blocks of 100kW @ \$898 Per KW Versus Current Rate (Per Month, IF NEEDED)	\$71,783
	= \$1,616 * 100KW	= \$898 * 100KW		
\$161,600	\$89,800			

SunGard Contract Information



- Approximate cost to relocate to a new Data Center - **\$43 million**
- Approximate cost to use another existing Data Center - **\$26 million**
- Approximate time to relocate to another Data Center – 18-24 months
- Potential financial risk - \$60 million in lost Federal Incentives stemming from the Electronic Medical Records Program (Meaningful Use)
- Total savings with new SunGard contract is **\$20.3 million** over 4 years



RESOLUTION

Authorizing the President of the New York City Health and Hospitals Corporation (the "Corporation") be and hereby is authorized to execute the third of three one-year renewal options available under the existing contract with Simpler North America, LP ("Simpler"). Funding for the exercise of the third of three one-year renewal options available under the existing contract shall not exceed \$5,500,000, inclusive of a 10% contingency, for the period from November 1, 2012 through October 31, 2013.

WHEREAS, in recognition of the breakthrough nature of improvements made using Lean techniques, in November, 2007, the Board authorized a contract with Simpler for Lean consultation and training to launch *Breakthrough* for a period of three years, and with two unfunded one-year renewal options, which contract was later amended with Board approval in October 2010 to add a third unfunded one-year renewal option; and

WHEREAS, the Corporation exercised the second of the three one-year renewal options on October 29, 2011 for an amount not to exceed \$4,879,650; and

WHEREAS, unless the Corporation exercises the third of the three one-year renewal options, the contract will expire October 31, 2012; and

WHEREAS, Simpler has provided Lean consultation and training effectively and satisfactorily to staff at nineteen Corporation sites including Central Office, and the Corporation expects to continue to deepen *Breakthrough* learning and engagement at these sites, to expand the adoption of *Breakthrough* at two additional sites, to align *Breakthrough* activities with strategic goals, and to strengthen *Breakthrough* infrastructure in order to build greater internal lean expertise, sustain improvements and reduce reliance on Simpler over time; and

WHEREAS, the Corporation has realized \$20.3 Million in cost savings and \$240.8 Million in new revenues through 1,141 *Breakthrough* improvement events, reaching 7,047 employees; and

WHEREAS, the overall management of this contract will be under the direction of the Senior Vice President for Organizational Innovation and Effectiveness.

NOW THEREFORE, BE IT

RESOLVED, that the President of the New York City Health and Hospitals Corporation (the "Corporation") be and hereby is authorized to execute the third of three one-year renewal options available under the existing contract with Simpler North America, LP ("Simpler") . Funding for the exercise of the third of three one-year renewal options available under the existing contract shall not exceed \$5,500,000, inclusive of a 10% contingency, for the period from November 1, 2012 through October 31, 2013.

EXECUTIVE SUMMARY

PURPOSE

HHC currently holds a contract with Simpler North America, LP, for Lean consultation and training.

HHC seeks to extend its fruitful contractual relationship with Simpler in order to gain further benefits from the vendor, including escalating ongoing efforts to develop the infrastructure and particularly HHC's leadership and management staff that will ultimately lead to HHC having the internal capacity to implement and sustain improvements without significant ongoing external support.

HHC proposes to execute the third of three existing, one-year renewal options in the contract at an amount not to exceed \$5,500,000 (this amount includes a 10% contingency to be exercised at the sole discretion of HHC's CEO). This period will commence November 1, 2012 and expire October 31, 2013.

BACKGROUND

In November 2007, the New York City Health and Hospitals Corporation (HHC) executed a contract with Simpler Consulting, Incorporated (now Simpler North America, LP) for a three year period ending October 31, 2010. This contract for Lean training and consultation was procured through a competitive Request for Proposals process. From five qualified respondents, Simpler was selected based on experience, approach and cost.

CONTRACT HISTORY

Process and Date	Period/Purpose	Amount	Cumulative Total
Approval of original contract (November 2007)	Years 1-3 (11/1/07 - 10/31/10) with 2, 1-year optional renewal years	\$5,000,000 for Years 1-3	\$5,000,000
First Amendment (January 2010)	Increase budget authority for the original period (Years 1 – 3) to add depth and breadth to contractor scope*	Add \$2,000,000 to Years 1-3	\$7,000,000
Renewal and Second Amendment (October 2010)	Execute the first of 2 optional renewal years (Year 4: 11/1/10-10/31/11) and add a third optional renewal year to ensure development of all sites and build self-sustaining infrastructure	Add \$3,112,700 for Year 4	\$10,112,700
Renewal and Third Amendment (October 2011)	Executed 2 nd of 3 optional renewal years (Year 5: 11/1/11-10/31/12)	Add \$4,879,650 for Year 5	\$14,992,350

*develop a larger cadre of internal Breakthrough experts, increase the length of the Contractor's consultants (sensei) engagement at each site in order to make deep, substantive improvements within critical value streams.

The contract is managed by Joanna Omi, Senior Vice President in the Division of Organizational Innovation and Effectiveness. Simpler has performed well, providing onsite training and consultation that enabled HHC to generate site-specific and enterprise-wide improvements.

OUTCOMES TO DATE

In the almost five years that HHC has implemented Breakthrough with Simpler's support, \$261.1 million in new revenues and cost savings have been realized. In addition, 5,720 staff has participated in Breakthrough activities and 1,141 Rapid Improvement Events have been completed. The cumulative return on direct investment for the first four years of this contract is \$261.1 million on a contract expense of \$14,992,350. Breakthrough has now been implemented at 19 of HHC's major sites¹ resulting in improvements in areas such as peri-operative services, emergency departments, inpatient units, ambulatory care, revenue cycle, imaging and behavioral health. Not only has this effort resulted in increased revenue and cost savings but it has also improved safety, efficiency and capacity, and decreased patient waits, unnecessary staff and patient movement and un-needed steps in numerous processes. ROI continues to grow at an increased rate, even over the last year when adjusted for gains recorded for two years in inpatient documentation and coding (\$5.74 in FY11, \$8.40 in FY12).

CONTRACT SCOPE

During the proposed one-year period, Simpler will focus on four strategic areas that have been identified as critical to Breakthrough and HHC's success:

- Strengthening HHC's Breakthrough infrastructure at the leadership, Corporate and site levels toward increasing capacity to manage without Simpler assistance;
- Developing and implementing Breakthrough at two new sites (East New York Diagnostic and Treatment Center and Dr. Susan Smith McKinney Nursing and Rehabilitative Center);
- Supporting key value streams through assigned Simpler Sensei to increase event productivity as well as develop and spread model value streams across the sites;
- Provide targeted coaching to HHC managers to implement "Managing for Daily Improvement" to ensure implementation of Breakthrough tools and philosophy at all levels of the organization and ensure sustainment of gains made through rapid improvement events; and,
- Improve the alignment of Breakthrough efforts with strategic goals including assigning Simpler staff to concentrate on key Value Streams and provide direct support to Breakthrough staff to learn and use more advanced Breakthrough tools.

Simpler will support the following activities this budget period:

- Implement Breakthrough at 2 additional sites: Breakthrough will be implemented at Susan McKinney Nursing Center and East New York D&TC over the course of the 12 month budget period. Onsite Simpler sensei support will be provided at these sites to train staff, facilitate early improvement, coach leaders and work with process owners to embed Breakthrough tools throughout operations.
- Provide onsite, regular consultation: Dedicated Simpler sensei will be assigned to sites according to the sites' competency and plans. Sensei will support improvement activities in increments of 4.5 days ('weeks'), with the number of these weeks per site per month varying from twelve to twenty-four during this 12 month budget period.

- Provide focused support of strategic value streams: Simpler will allocate .5FTE (equivalent to 2 weeks per month) to support of one or two specific value streams that are active across the enterprise, e.g., peri-operative services, emergency departments, ambulatory care or mental health services. Simpler will work with the enterprise Breakthrough office and individual sites to identify effective Breakthrough practices that have relevance to other sites, and to spread these across and within sites. This activity will provide a showcase of best practices as well as engage sites for more rapid, systemic spread.
- Provide transformation program management, core team development, developing transformation policies, data collection and analytics, organization design, Breakthrough training and certification, lean capability assessments and assistance in building the HHC Business Improvement System Executive Coach will be on-site 4 weeks per month providing executive coaching aligned with the deployment of Hoshin Kanri, TPOC reviews and other strategic initiatives at all active sites. Monday noon until Thursday afternoon will be the normal on-site engagement.
- Development and project management: Simpler will allocate .5FTE sensei (equivalent to 2 weeks per month) to planning and continued development of Breakthrough, the HHC Improvement System in collaboration with and under the management of the Senior Vice President, Organizational Innovation and Effectiveness. This work will include expansion of prior Hoshin Kanri/Strategy Deployment activity, identification and deployment of advanced tools and strategies at the enterprise and site level, leadership development and training, and facilitation and alignment of all communications between site and other sensei assigned to HHC.
- Training: Simpler will continue to provide support for select facilitator certification training, including Silver, Gold and Platinum levels, as well as additional targeted training. In all training, the process will facilitate the development of internal HHC capacity to conduct these courses.

Contract Benefit to HHC:

November 1, 2012 through October 31, 2013:

- New Revenue: \$ 85 million Cost Savings: \$10 million
- Other anticipated outcomes of Breakthrough efforts include:
- Number of Rapid Improvement Events: 300
- Number of additional employees participating in Breakthrough Event: 1,600
- Leadership will be more skilled and knowledgeable about the application of tools to plan, implement and sustain Breakthrough activities.
Managers will be able to improve their own and their areas of responsibility's productivity through the use of Breakthrough tools and philosophies on a daily basis
- Sites will have increased capability to manage projects, increase the effectiveness of their Breakthrough events and the ability to use more advanced tools to achieve greater success. Employees will be empowered to problem solve and improve the processes in their own areas.
- Patient and employee satisfaction will be increased due to the elimination of wasteful, unneeded processes, wait times and unnecessary movements.

CONTRACT MANAGEMENT

The contract will continue to be monitored by Joanna Omi, Senior Vice President, the Division of Organizational Innovation and Effectiveness.

¹ Breakthrough had been adopted at Central Office, Queens Hospital Center, Metropolitan Hospital Center, Jacobi Medical Center, Gouverneur Healthcare Services (D&TC and SNF), Renaissance, S.R. Belvis, Morrisania and Cumberland Diagnostic and Treatment Centers, Coney Island Hospital, Bellevue Hospital Center, North Central Bronx Hospital, Woodhull Medical and Mental Health Center, Kings County Hospital Center, Lincoln Medical and Mental Health Center, Elmhurst Hospital Center, Harlem Hospital Center, Coler Goldwater Specialty Hospital, and Health and Home Care.

**Health and Hospitals Corporation
Contract Review Committee
Contract Approval Form**

Date: 9 October 2012

**To: Joanna Omi
Lawrence Hansley**

Document Control Number: 2015

**Description: Application to enter into contract with Simpler North America, L.P. for training, consultative and planning services to support HHC's Breakthrough Program on behalf of the New York City Health and Hospitals Corporation, Division of Corporate Planning and HIV Services.
DCN: 2015**

The Contract Review Committee (CRC) reviewed the requested materials subsequent to the October 3, 2012 meeting. The CRC has issued authorization via an electronic vote to submit your application to the Board of Directors.

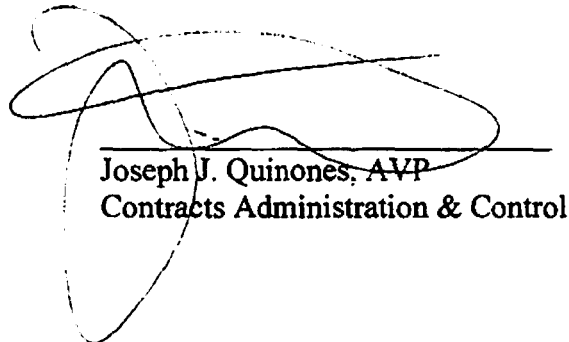

**Joseph J. Quinones, AVP
Contracts Administration & Control**

File



NEW YORK CITY HEALTH AND HOSPITALS CORPORATION
125 Worth Street · Suite 401 · New York · New York · 10013
212-788-3380 · Fax: 212-788-3689 · E-mail: manasses.williams@nychhc.org

Manasses C. Williams
Assistant Vice President
Affirmative Action/EEO

TO: Larry Hansley
Division of Organizational Innovation and Effectiveness

FROM: Manasses C. Williams 

DATE: September 18, 2012

SUBJECT: EEO CONTRACT COMPLIANCE REVIEW AND EVALUATION

The proposed contractor/consultant, Simpler North America, LP., has submitted to the Affirmative Action Office a completed Contract Compliance Questionnaire and the appropriate EEO documents.

This company is a:

Minority Business Enterprise Woman Business Enterprise Non-M/WBE

Project Location(s): HHC- Citywide

Contract Number: _____ Project: Lean Consulting Services

Submitted by: Division of Organizational Innovation and Effectiveness

EEO STATUS:

1. Approved
2. Approved with follow-up review and monitoring
3. Not approved

COMMENTS:

MCW:pat

c:



SIMPLER CONTRACT RENEWAL AND AMENDMENT

Presentation to the HHC Board of Directors

October 18, 2012

Simpler North America

-- Support for Breakthrough --

- Contract Background
- Progress and Results
 - Enterprise
 - Sites
- Proposed Contract
- Future Plans

Background

- Breakthrough initiated November 2007
- Simpler procured via competitive RFP
 - **SCOPE:** Lean consultation and support services
 - **TERM:** 3 years (2007—2010 with 2 one-year optional renewals)
 - **ORIGINAL BUDGET:** \$5M
 - **FIRST AMENDMENT:** Increase total to \$7m; no change in term (January 2010)
 - **SECOND AMENDMENT AND RENEWAL:** (October 2010)
 - Exercise first one-year renewal option (Year 4)
 - Add \$3.1m for Year 4
 - Add a third optional renewal year to the contract (for a total potential of 6 years)
 - **THIRD AMENDMENT AND RENEWAL:** (October 2011)
 - Exercise second one –year renewal option (year 5)
 - Added \$4.9 m for year 5
 - Total contract amount through Year 5 = \$ 14,992,350

Active and Planned Sites

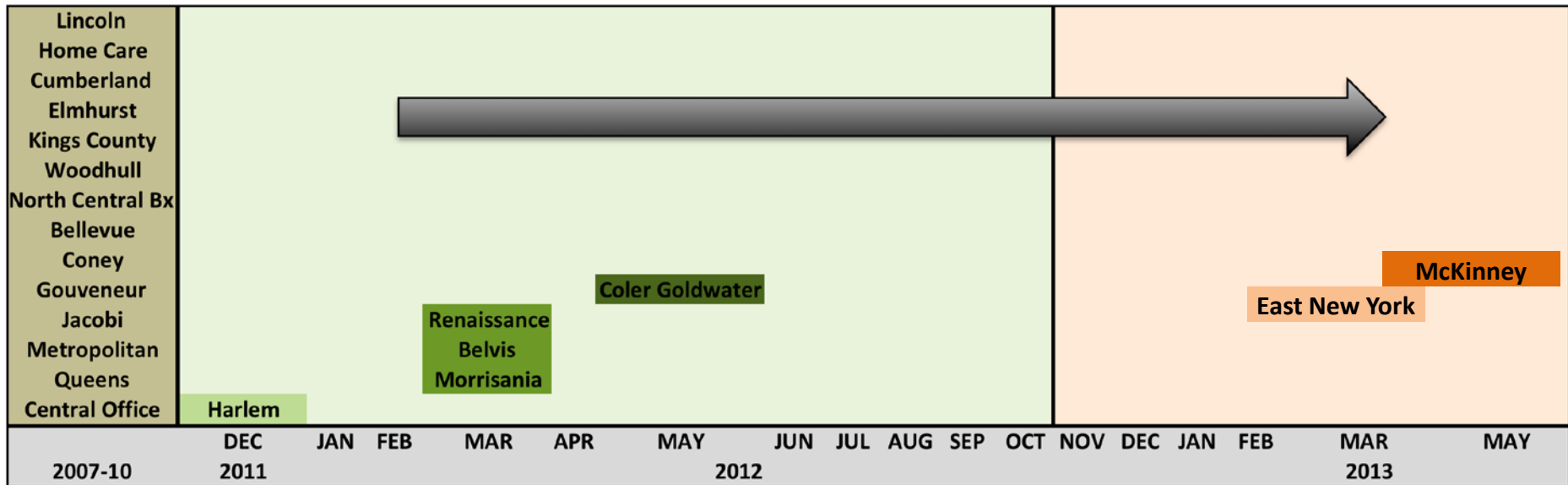

- 19 active sites
- 65 active value streams
- 2 additional sites to launch in 2013 (East New York, McKinney)
- 2 additional sites to launch in 2014 (MetroPlus, Sea View)
- With these last two sites, all acutes, D&TCs, LTCs, MetroPlus and Home Care will have adopted Breakthrough

Developing Self-Sufficiency

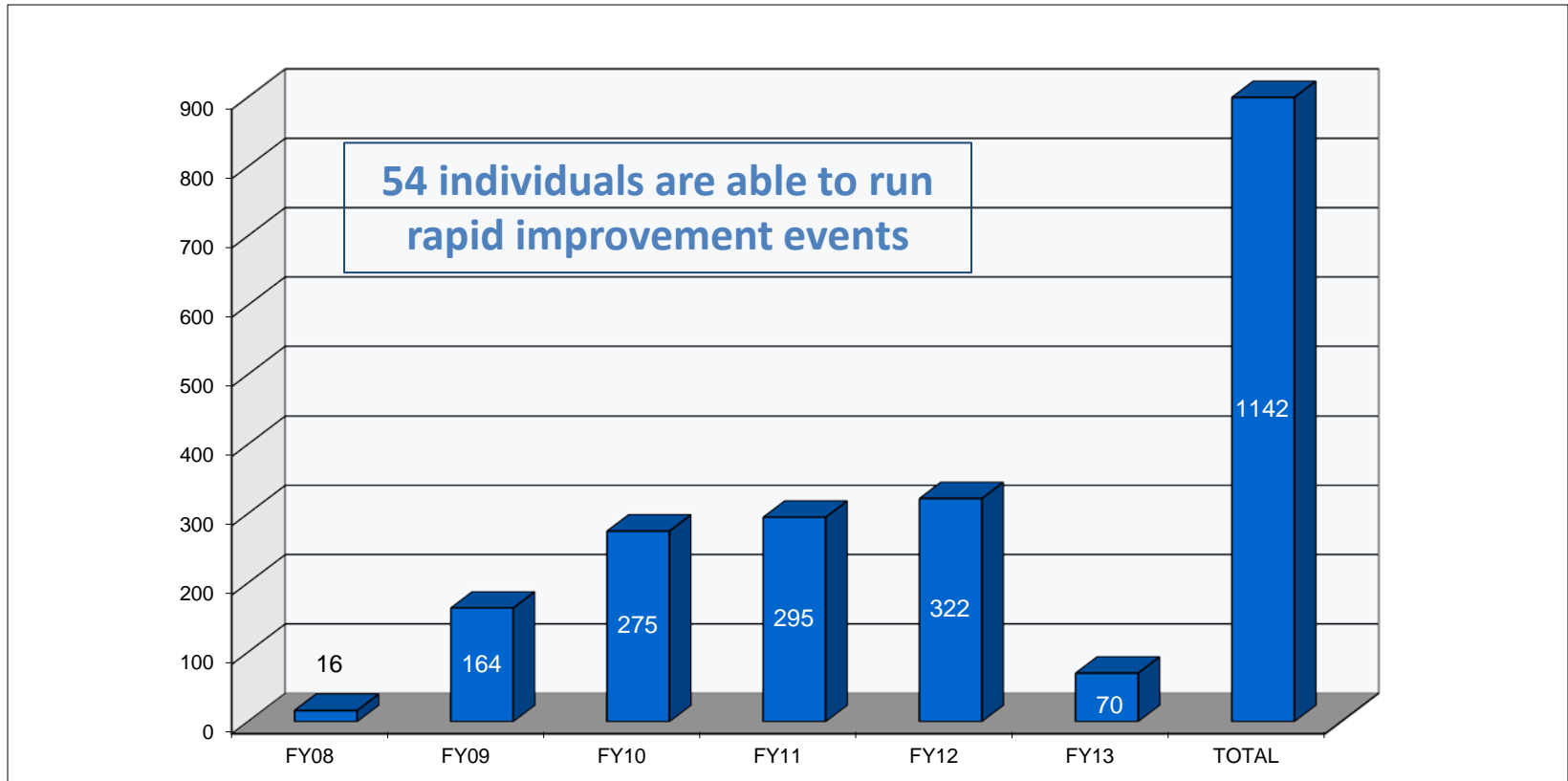

- 1,142 Rapid Improvement Events to date
- 38 Full-time Facilitators, 16 embedded & part-time facilitators
- 14 Breakthrough Deployment Officers

Breakthrough Classes By Fiscal Year

Certification Classes

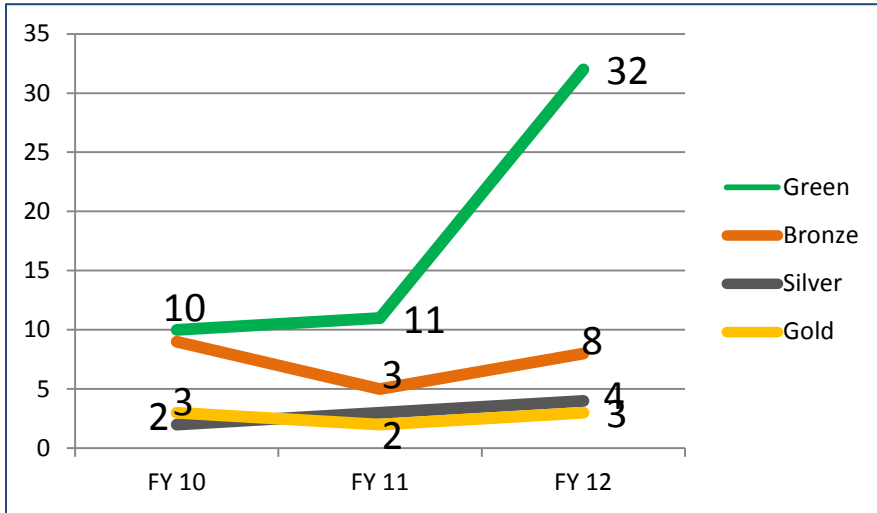

Non-Certification Classes

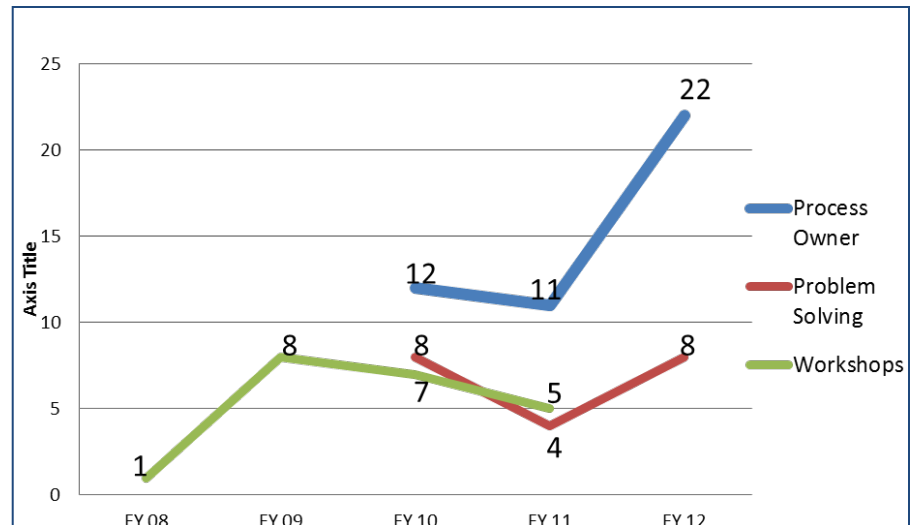

Certification Classes:

- Green = 1 day
- Bronze = 3 days
- Silver = 2 weeks
- Gold = 2 weeks
- Platinum = 1 year

2,071 People have Participated in Breakthrough Training

Green*	Bronze	Silver	Gold*	Process Owner	Workshops	Problem Solving
Certified	Certified and Pending Certification	Certified and Pending Certification	Certified and Pending Certification	Completed	Completed	Completed
946	105/103	42/66	4/32	523	217	216

- All engaged sites are home to at least:
 - 30 **Green** graduates (Woodhull = 123)
 - 9 **Bronze** graduates (Woodhull= 28)
- 18 sites are home to 1 or more **Silver** graduates (NBHN = 8)
- 11 sites are home to 1 or more **Gold** trainees who are working on certification (Kings County, Lincoln, Metropolitan, NBHN = 4)
- 4 **Platinum** candidates are scheduled to graduate in early 2013

NOTES:

1. This is a duplicate count of training since May 2008; progression along certification levels requires completion of the previous level.
2. Enrollment in Process Owner, Workshops and Problem Solving does not require, but is often accompanied by, additional training.
3. Certification courses (Green, Bronze, Silver, Gold and Platinum, in ascending order) are sequential; enrollment requires passing the prior level. The first class of Platinum, the penultimate certification course, will graduate in early 2013.
4. Certification classes require completion of didactic (and as relevant, practical) training, successfully passing course exams and completion of post-class experiential requirements.

Embedding and Retain Expertise

- Breakthrough provides a career path (20, up 11 over the last year):
 - 3 Chief Operating Officer (**Fugazy, Hicks, McLeod**)
 - 1 Executive Director (**Soares**)
 - 1 Executive Vice President (**Martin**)
 - 1 CFO (Moran)
 - 7 AEDs/Service Line Directors (**Hixson, Mastromano, Mazhar, Mulvihill, Parathath, Sherwood, Smith**)
 - 1 Managed Care Director (**Free**)
 - 1 Ambulatory Care Manager (**Wint-Johnson**)
 - 1 Senior Vice President (**Omi**)
 - 1 CIO (**Patterson**)
 - 3 Breakthrough Deployment Officers (**Baumann, Robertson, Tarnovsky**)

Promoted from:

--Breakthrough Deployment Officer

--Facilitator

--Breakthrough champion

Broadening the Reach

- Clinical champions: physician leaders, primarily but not limited to chiefs of service, provide significant leadership at sites:
 - 3 Chiefs of Surgery
 - 3 Chiefs of Anesthesiology
 - 10 Chiefs and other MDs in Emergency Medicine
 - 3 Chiefs of Psychiatry
 - 2 Chiefs of Medicine
- Engaged cabinet members (leadership teams)
- Cascading hoshin kanri through level 3

Approximately 18% of Employees and Affiliate Staff have Participated in Training and Events

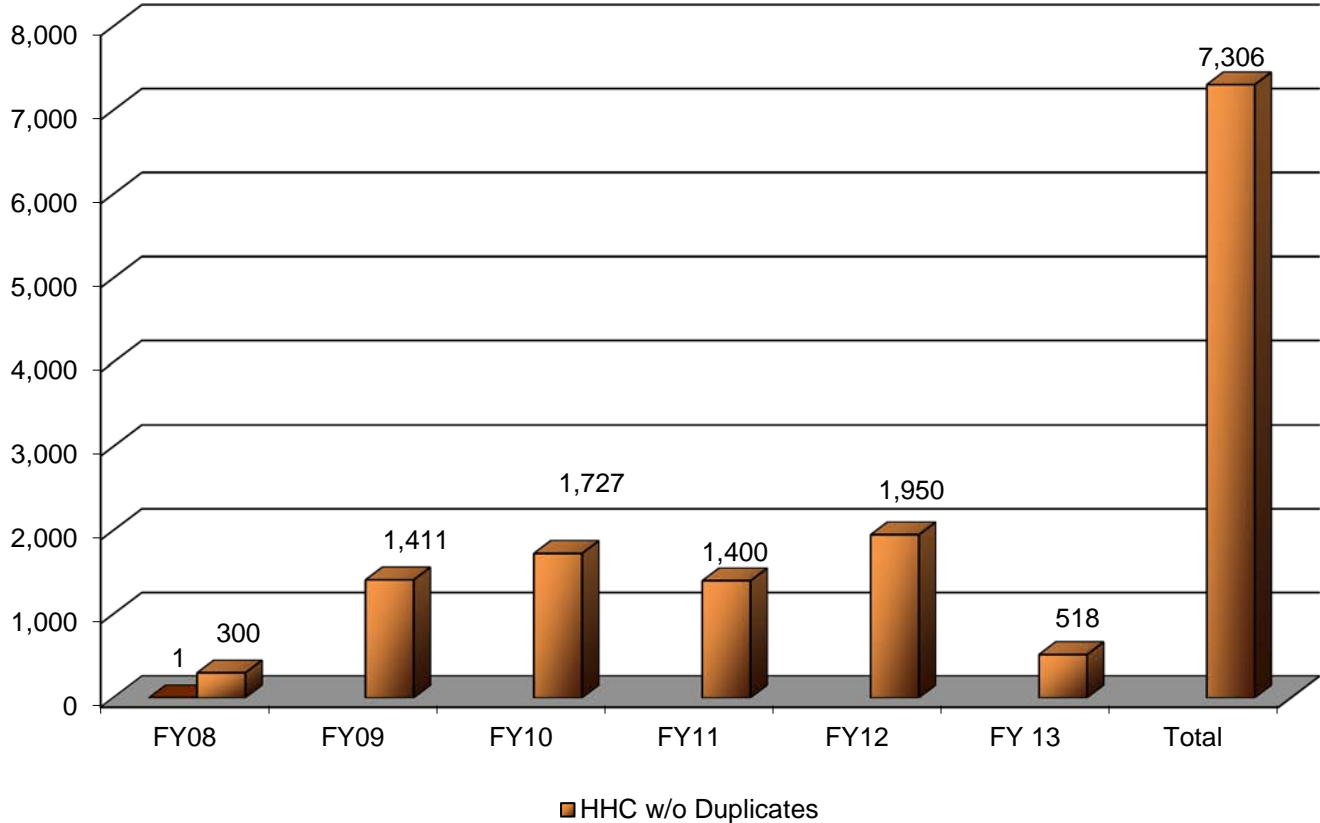

Financial Benefits

New Revenues (\$240.8M) + Cost Savings (\$20.3M)=\$261.1 M*
 Inpatient Documentation & Coding Accounts for 57.7% of revenues

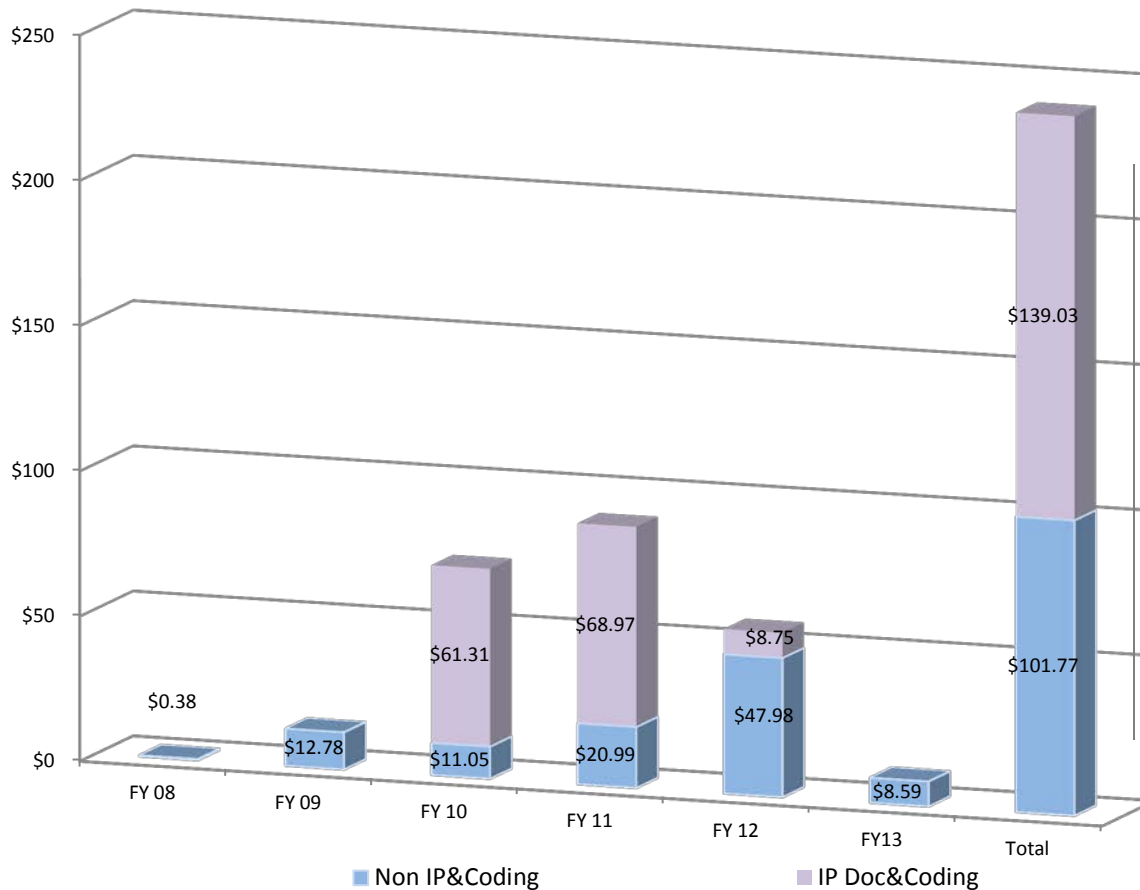

* Represents the total cumulative savings and new revenue generated from Breakthrough improvements since November 2007.

New Revenues Continue to Grow

(in millions)

Exclusive of the 'I/P Documentation and Coding' contributions, the financial contributions of facility value streams and other sources are significantly growing each year

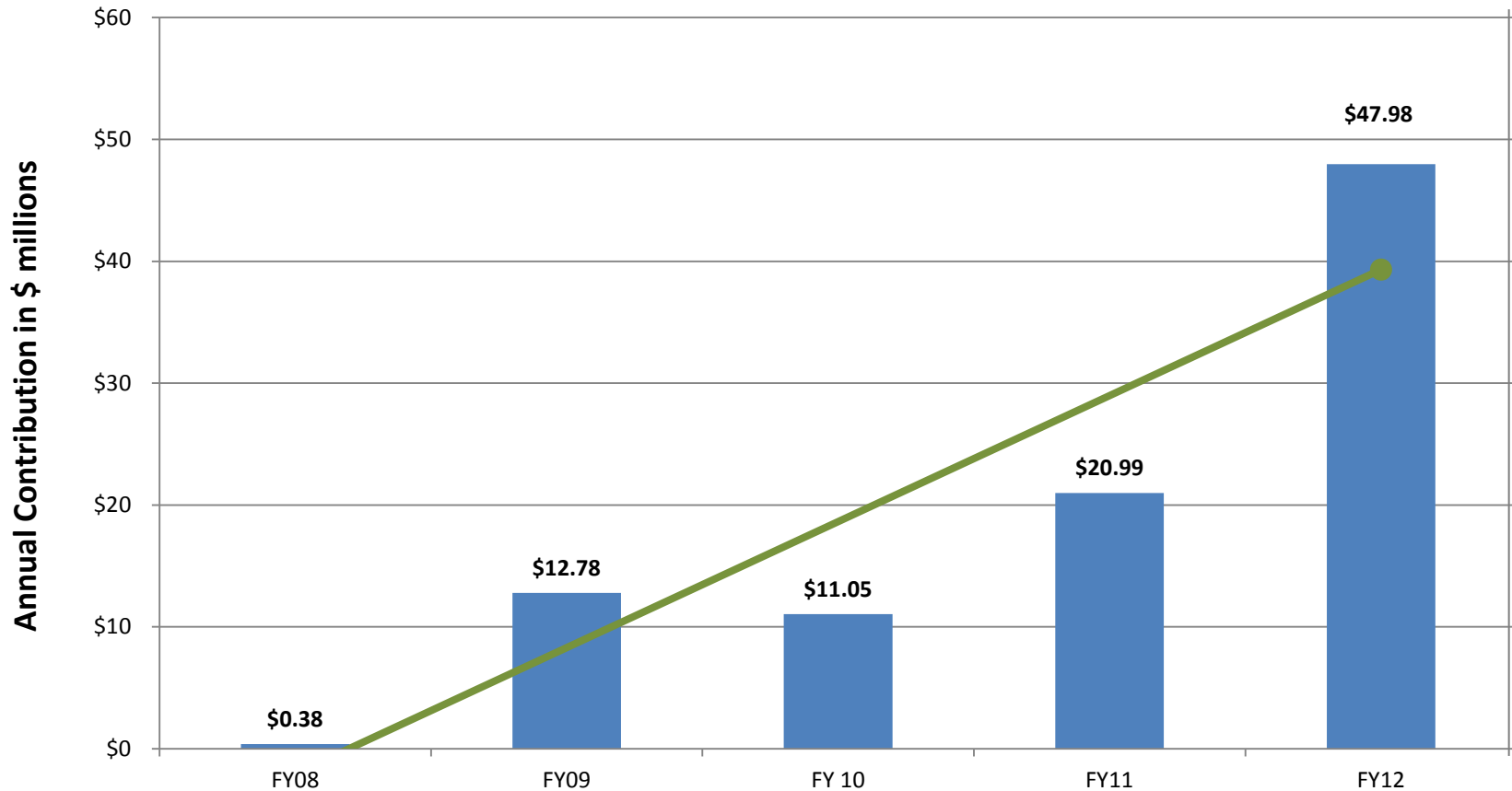

Strong Return on Investment

Financial Benefit per \$ Consultant Cost

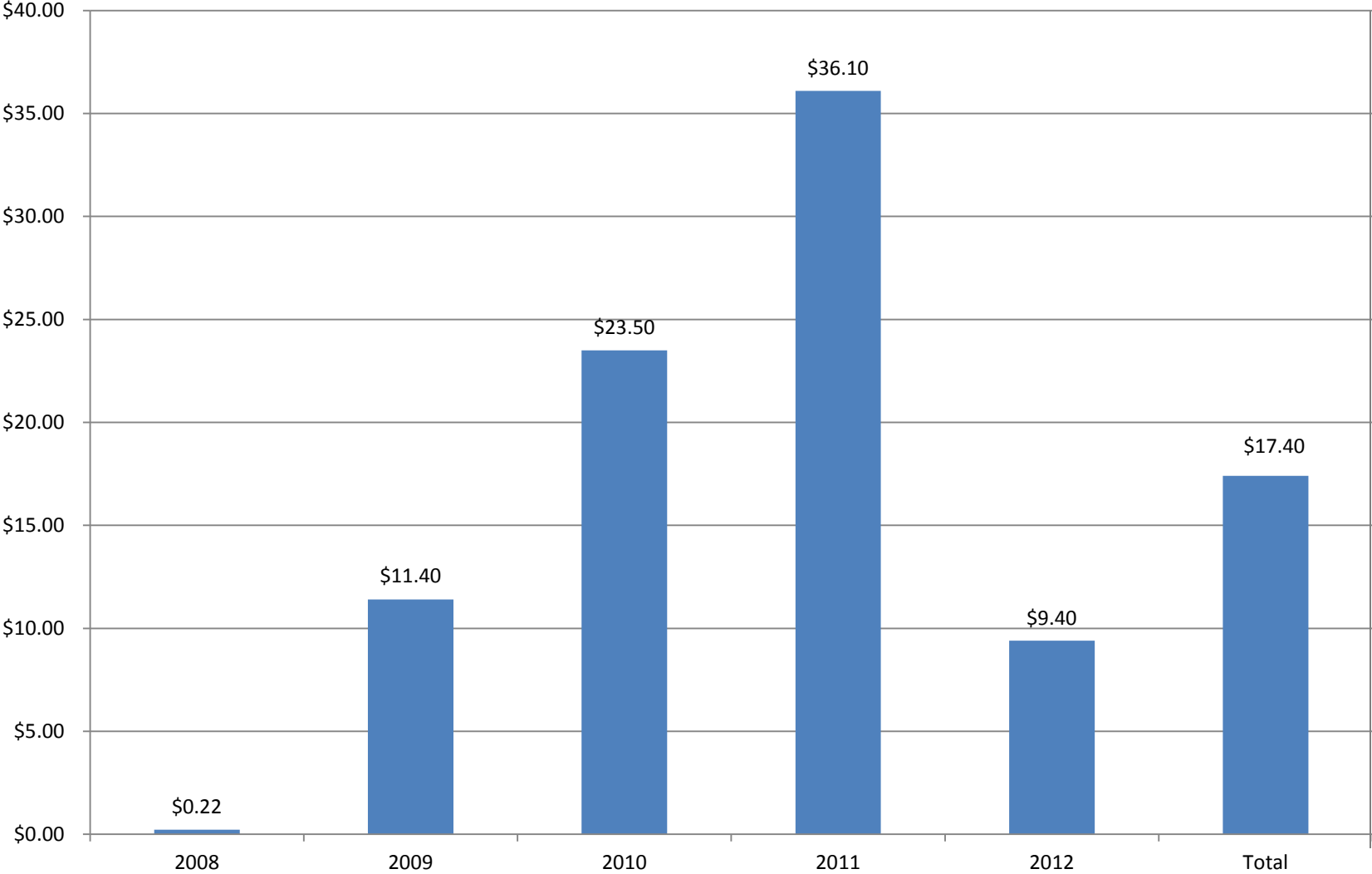

Bellevue Hospital Center

Patient Discharges

- **Problem:** Emergency Department got backed up due to lack of available beds upstairs. MD and RN discharge-related activity was variable and inconsistent.
- **What we did:**
 - MDs use a standardized algorithm to discharge patients
 - 24 hours prior to discharge during interdisciplinary rounds nurses initiate discharge process
 - On the day of discharge, RN begins discharge instructions before discharge orders are entered
 - Pharmacy and Social Work communicate with the team once their parts of the process are complete
 - Physicians indicate pending discharge in Echo test request comment field
 - MDs order blood draws for 10:00 pm sweep for potential discharges
- **Results:**

Percent Patients Discharged and Orders Received by Target Times of Day

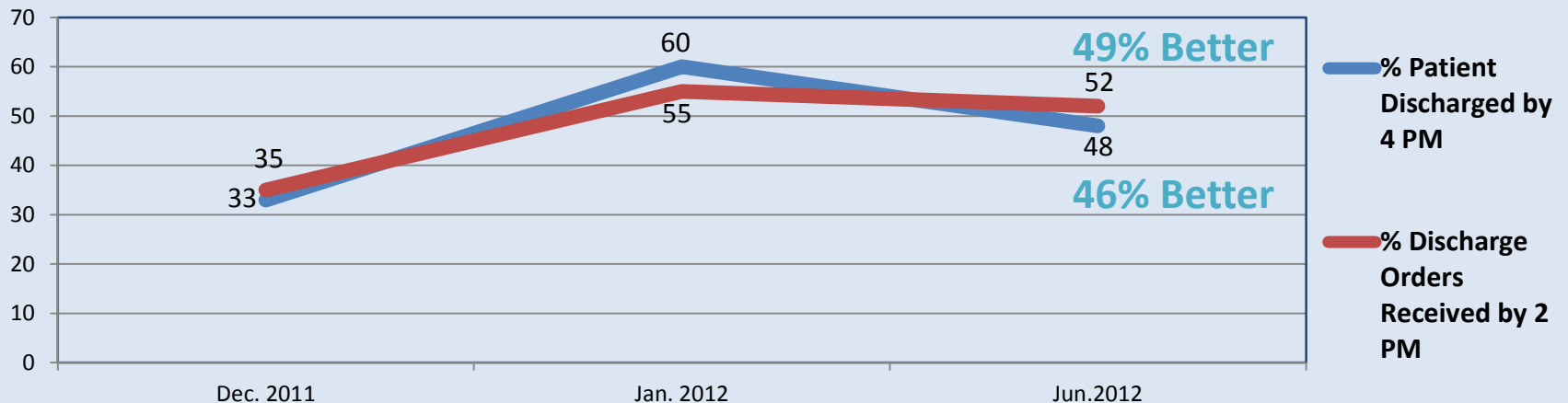

Central Office Finance Department

1% Increase in Medicaid Application Approval Rate

Problem:

- Inpatient FFS revenue decreased in FY11
- Number of Medicaid eligible decisions decreased in FY11

RESULTS:

- Shortened application submission time
- **\$ 8.2 Million in Medicaid Revenue**
- Increase in Medicaid application approvals at 9 of 11 hospitals
- Improved staff satisfaction – sense of accomplishment

WHAT WE DID:

- Earlier patients interviews - conducted in ED
- Established two models to standardize HCI case assignment.
- Standard work for Emergency MA application process

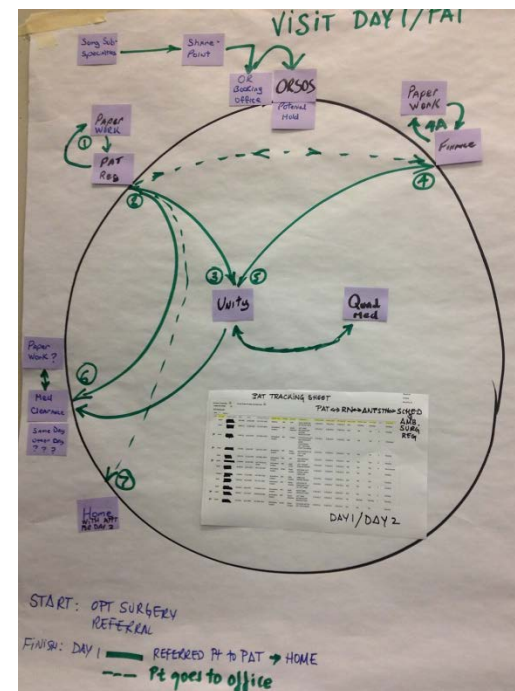

Coney Island Hospital

Inpatient Behavioral Health: Improved Patient Satisfaction

Problem: Patient satisfaction low for patients discharged from the psychiatric inpatient units

What we did:

- Created guidelines for bedside rounds to ensure a concise discussion
- Afternoon Treatment Planning Conference time was decreased by approximately 50 % (to 45 mins), which enabled clinical team members additional time to conduct assessments, be available to see family members and complete documentation.
- Initiated morning bedside rounds with entire care team, which increased patient face time with the team.

Results: Significantly improved patient satisfaction scores

Question 1 I am satisfied with the amount of time I see my treatment team

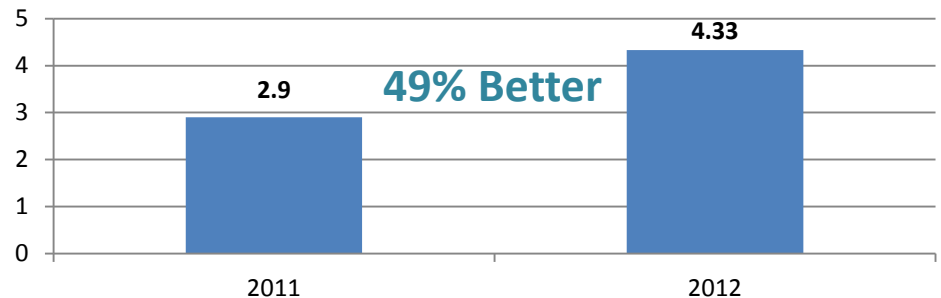

Question 2 I am satisfied with the time of day I see my treatment team

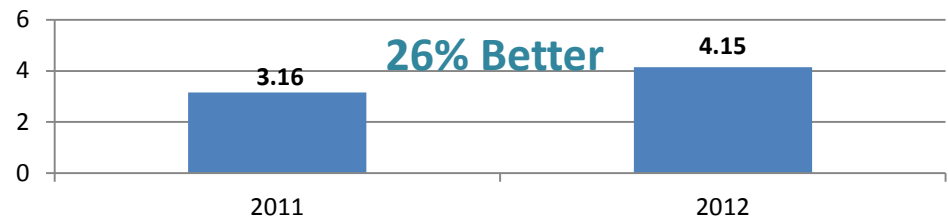

Question 3 I felt my treatment team was available when I needed them



Cumberland Diagnostic and Treatment Center

Adult Medicine : Assignment of Sick Patients to Physicians

Problem: Sick patients who walk in experience long waiting times to see a provider and receive services

What we did:

- Standardized fast track process for medication refills
- Developed flow master to monitor template in real time
- Improved communication between flow master and clerks
- Created signage to identify patients with appointment

Results:

Average Patient Cycle Time In Minutes

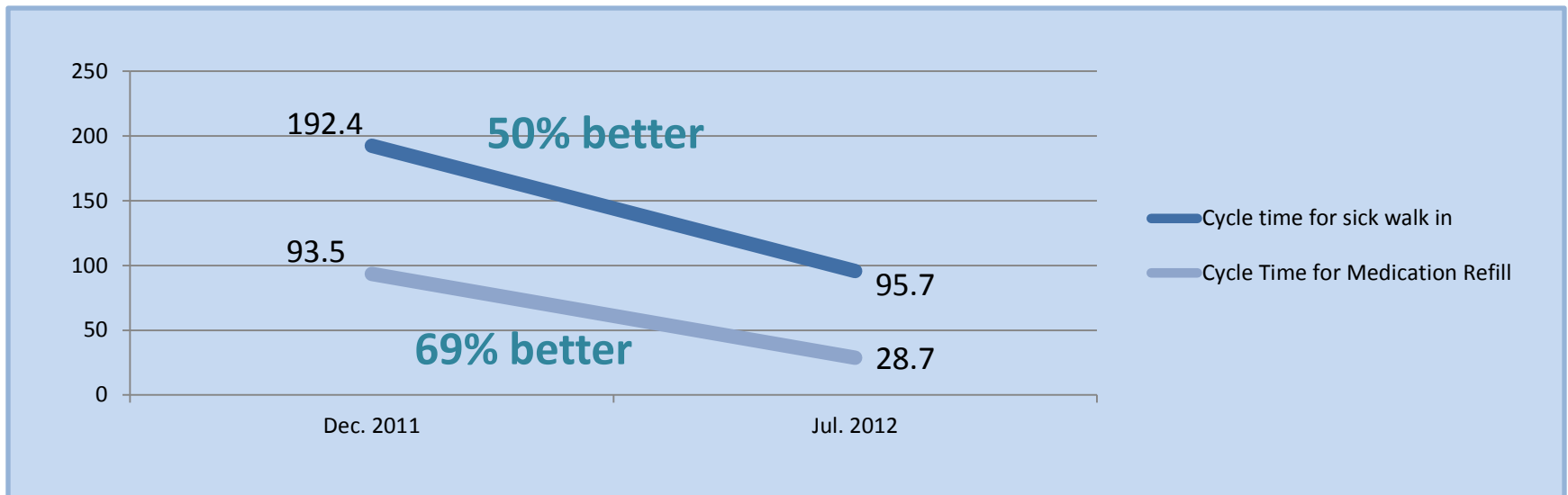

Elmhurst Hospital Center

Primary Care Medicine Visits

Problem: Patient flow in Primary Care Medicine clinic results in physician capacity being underutilized (physicians spend a lot of time waiting for patients to be put in room)

What We Did:

- Standardized work for staff
- Visual Management System to manage patient flow (Process Control Board)
- 1st visit start time coordination
- No patient batching
- Use of daily “Briefs”

Results: MD productivity increased significantly. In FY 2012, 4,476 more patient visits in PC Medicine Clinic than FY 2011 while time MDs spent without a patient was essentially eliminated.

% of MDs Without a Patient

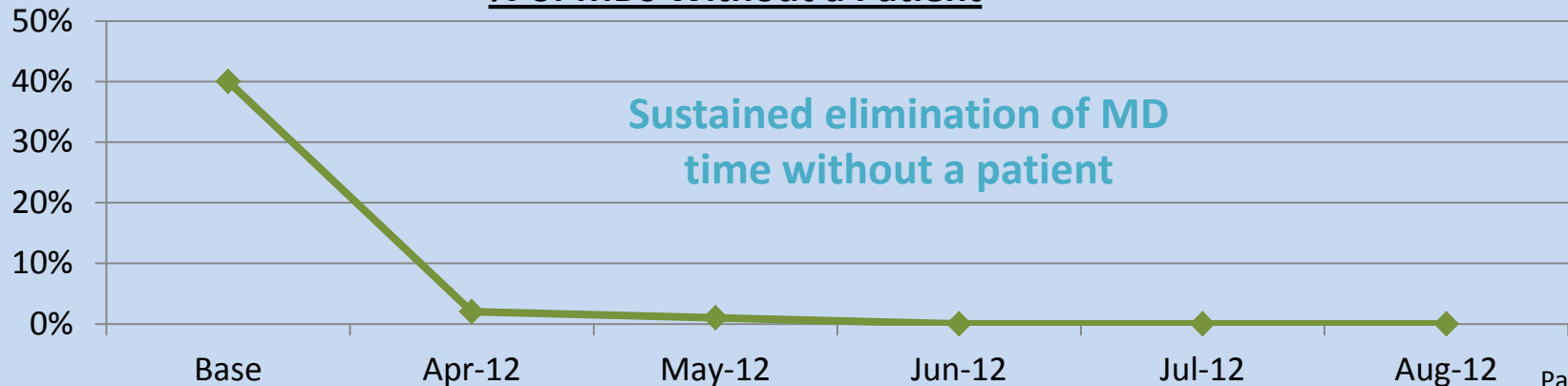

Generations+ Diagnostic & Treatment Centers

Patient Insurance Information Verification and Recording

Problem: Patient visit cycle time is increased by missing or incorrect insurance information.

What We Did:

- Standard work developed for the collection and recording of patient insurance information.
- Signage installed for patients to avoid unnecessary time looking for services.
- Clerks check appointment and verify insurance prior to visit

Results:

Average Patient Cycle Time to Complete Registration Process (in minutes)

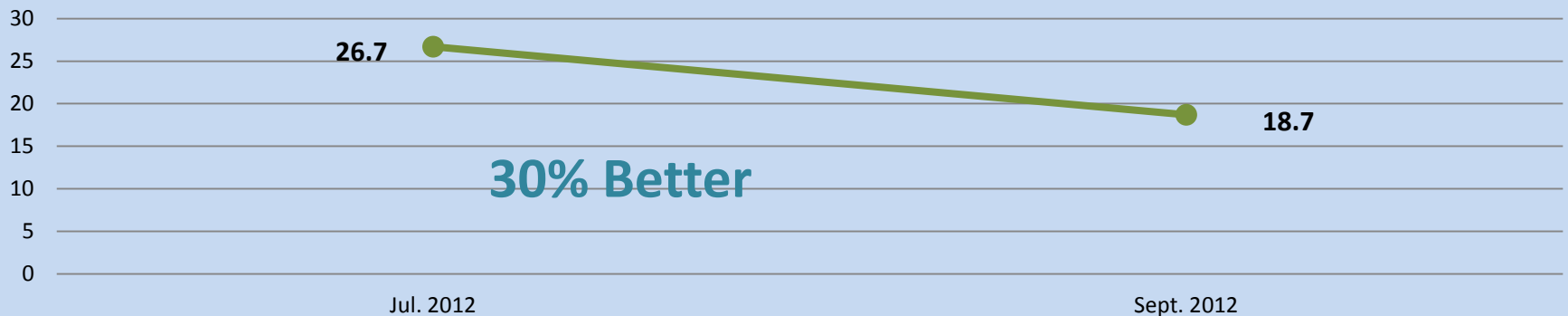

Harlem Hospital Center

Peri-Operative Services Financial Clearance

Problem: Pre-operative patients were required to go to multiple areas to complete financial clearance resulting in incomplete clearances and patient delays for procedures

What we did:

- Elimination of form 1875 (internal communication between Finance and other services)
- Decreased 30 minutes of patient waiting time
- Eliminated unnecessary trips to Financial Services and Pre-Admission Testing
- Created standard work including scripts for all areas to communicate to patients

Results:

Percent of patients Presenting for Financial Clearance

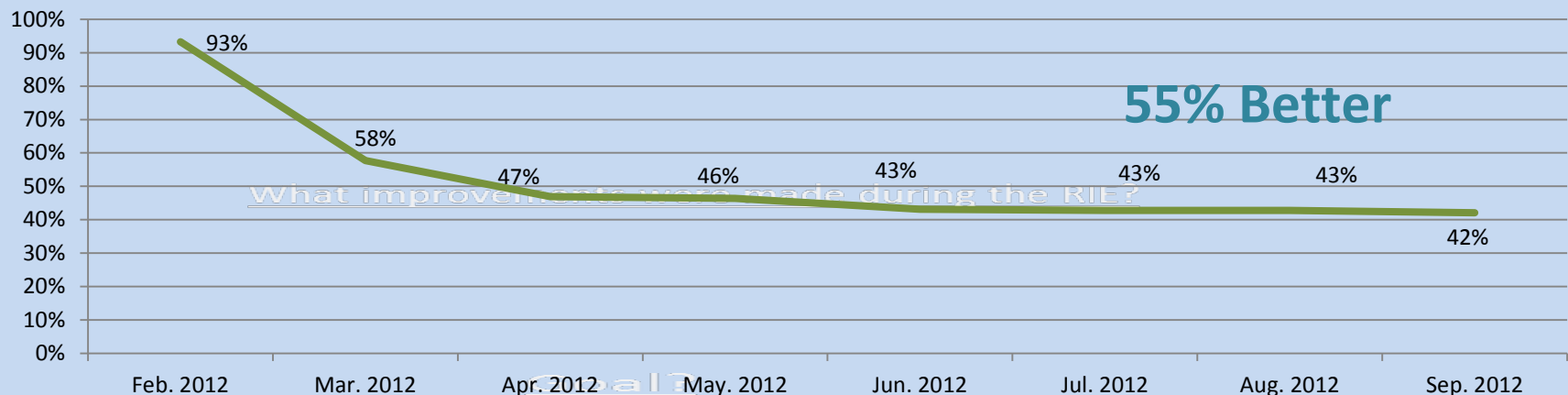

Health and Home Care

Decreasing HMO Denials of Claims

Problem: Reauthorization requests were being submitted late resulting in a large number of HMO denials of claims.

What we did:

- Electronic Production Control Board shared with clinicians weekly
- Consistent follow-up with clinical staff on timely submission of re-authorizations
- Adherence to standard work processes to improve accountability and follow-up by clinicians

Results:

Claim Denials as Percentage of Total Revenue

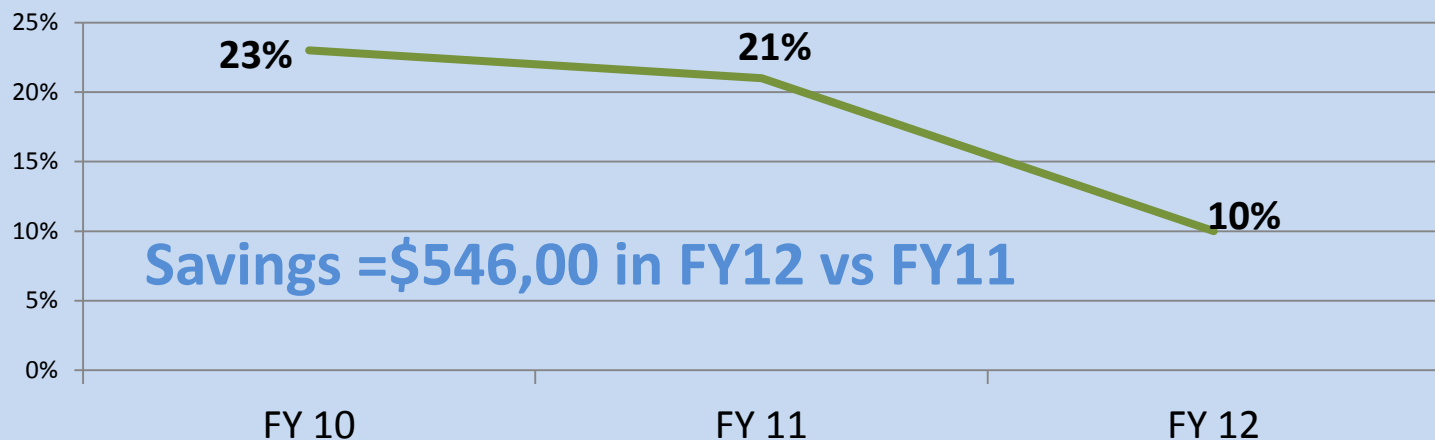

Jacobi Medical Center

Improved Continuity of Care for Inpatients

Problem: Patients were being assigned to beds/units not consistent with the location of their assigned MD/care team. This compromised continuity of care and communication among the care team.

What We Did:

- Created a designated work station for Senior Medical Resident proximal to Bed Control Board.
- Moved chronic patients to same unit
- Gemba rounds for the Senior Medical Resident
- New intake report to better identify location of patients

Results:

% of Patients in Units of Assigned Teams

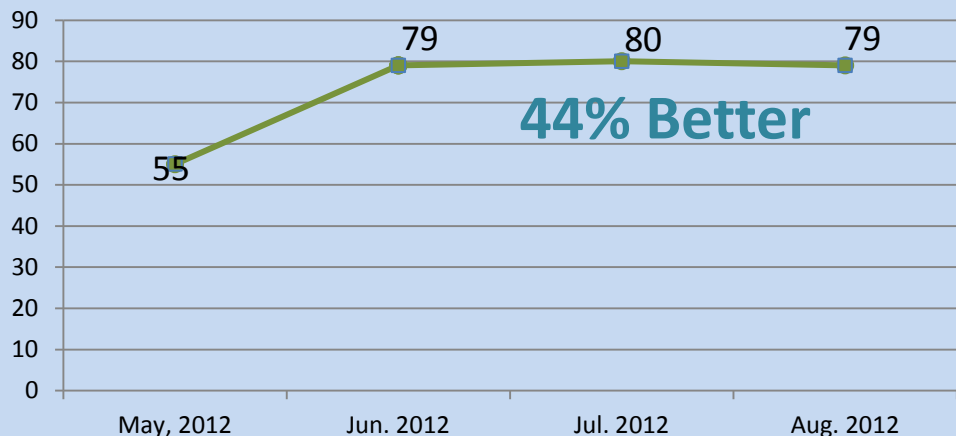

Confirmed State In-Patient Flow VSA

TN	Measurements	Base Line	Target	June	July	August
Q	DC Notification to Pt within 24 hrs.	0%	100%	0%	10%	10%
Q	Discharge before 2PM	13%	50%	18%	20%	25%

Kings County Hospital Center

Congestive Heart Failure (CHF) Patient Readmissions

Problem: Discharge process for CHF patients was disjointed, unreliable and did not provide the patient with needed information and understanding of their post-discharge plan

What we did:

- Assembled a multi-disciplinary team involved in CHF discharge process for regular case review
- Team developed standard work for comprehensive CHF discharge planning
- Implemented and ensured compliance with standard work

Results:

Percentage of CHF Patients Readmitted within 30 Days

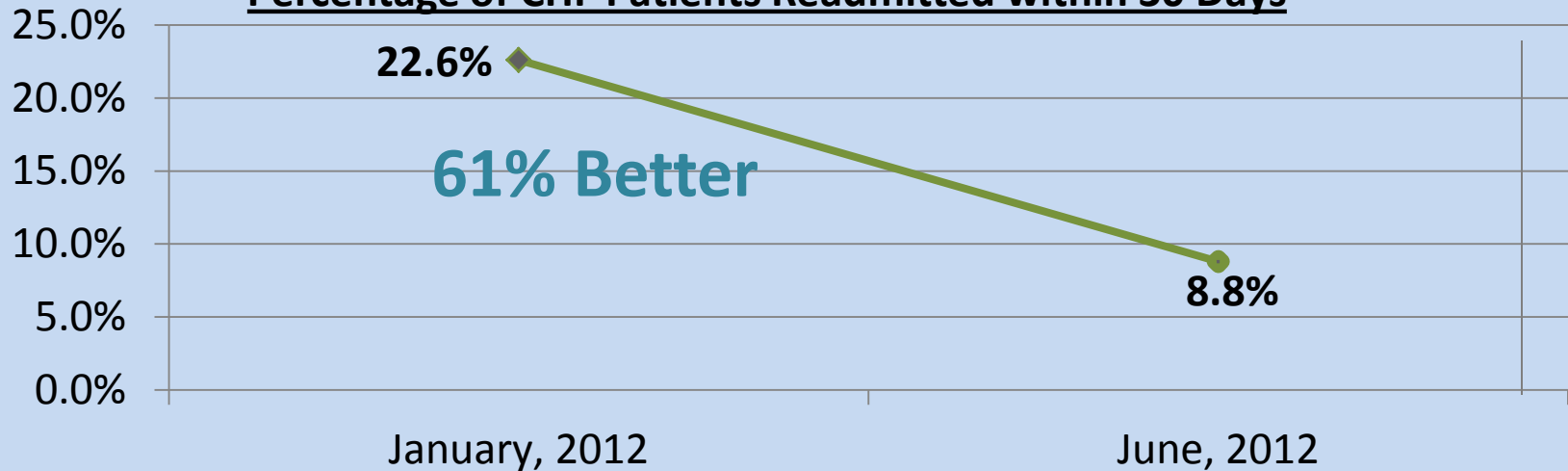

Lincoln Medical and Mental Health Center

Adult ED Walk Out Rate

Problem: Patients were leaving the Emergency Room without receiving services due to long waiting times and lack of patient engagement

What We Did:

- Streamlined the triage process to front-load lab and ancillary tests to reduce delays
- Installed white board for work flow management
- Established model cells for better communication among care providers

Results:

Percentage of patients that left before treatment



52% Better

**FY12 Revenue Increase
from Reduced Walk Out
Rate =
\$2,624,377**

Metropolitan Hospital Center

Congestive Heart Failure (CHF) Patients: Post Discharge Care Coordination

Collaborative effort between Metropolitan Hospital Center, Health and Home Care, and Metroplus

Problem: CHF patients averaged a 30% readmission rate within 30 days of discharge from our inpatient cardiology unit

What we did:

- Standardized inpatient management of HF patients
- Continuous patient teaching (RN, Cardio, Home Care, Dietary & SW)
- Post discharge care management (Telehealth/Home care)
- One week follow up in Cardiology Clinic
- Continuous collaboration – MET, H&HC, Metroplus

Results:

% of CHF patients admitted within 30 days of inpatient discharge
Average admission rate: Jan. 2010-Jan. 2011 vs. July 2011-April, 2012



Queens Health Center

Surgical Referral Center (SRC)

Problem: Underutilization of operating rooms due to difficulties in timely scheduling, medical and financial clearance of patients

What We Did:

- Fast track referrals for surgical procedures
 - SRC RN reviews CHN referrals to identify candidates for surgical procedures
- Standardized processes across QHN
 - Financial clearance
 - Medical clearance
 - Intranet P Trac scheduling program now used at both facilities-providers can see and book cases into the OR schedule at either hospital from any In-House PC
- Services currently utilizing SRC
 - Urology
 - Orthopedics
 - Podiatry
 - ENT
 - Cardiology
 - Vascular

Results: Increase of 285 surgical cases in OR in FY 2012 vs FY 2011

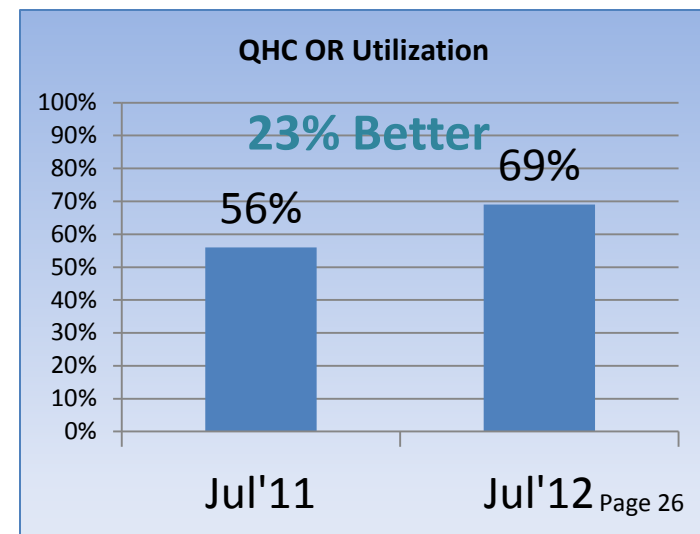
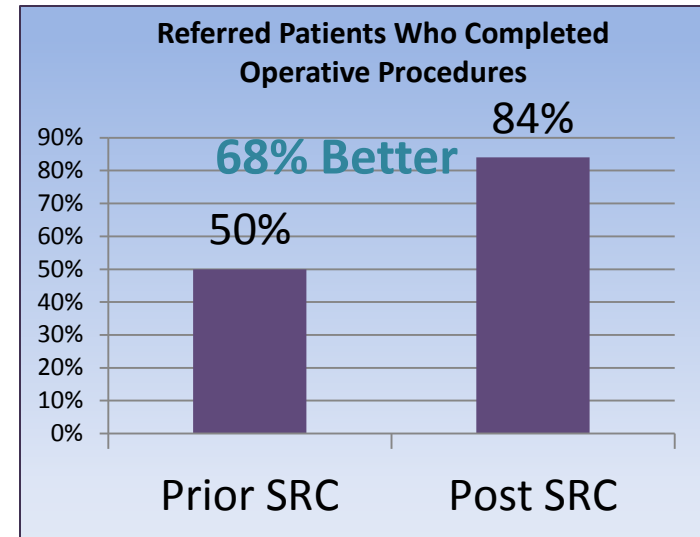

Woodhull Medical & Mental Health Center

Inpatient Psychiatric Unit Average Length of Stay

Problem: The average length of stay (ALOS) in inpatient Psychiatric Units varied greatly due to significant delays in discharging patients.

What we did:

- Conducted RIE on Unit 2 of inpatient psychiatric services
- Made expected discharge date on comprehensive Treatment Plan a meaningful data point
- Revamped the census to highlight discharge tasks
- Created calendar to focus on discharge

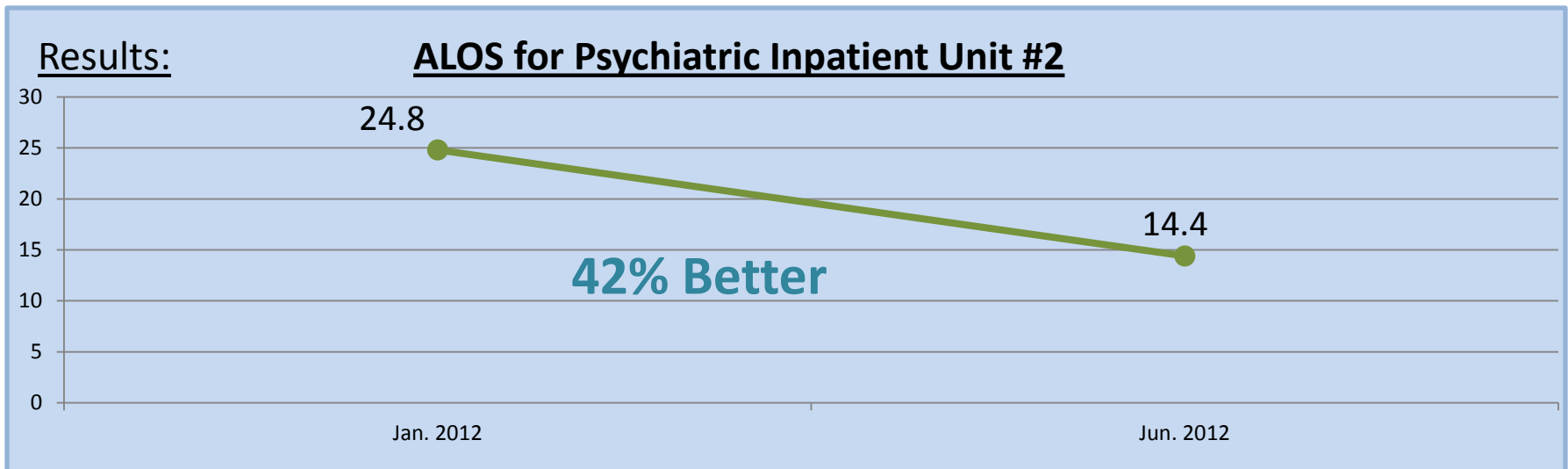

Proposal for Year 6

(November 2012 – October 2013)

- Authorize an additional \$5.5 M
 - inclusive of a 10% contingency
 - Results in a total, cumulative contract amount of \$20,492,350 over 6 years (Nov 2007 – Oct 2013)
- Exercise the third of 3 optional renewal years
- Scope: Continue and escalate development of internal capacity for Breakthrough maintenance and growth through strategic coaching and teaching

Collaborated and Coordinated Action

OBJECTIVE	SIMPLER ROLE	HHC ROLE
<p>SUPPORT STRATEGIC BUSINESS PRIORITIES</p> <p>Apply Breakthrough resources to support of strategic priorities</p>	<p>Coach and teach hoshin kanri through level 3</p>	<p>Develop and deploy X matrices and trackers through Level 3, manage monthly through data review and countermeasures</p>
<p>CONDUCT RAPID IMPROVEMENT EVENTS</p> <p>Continue to achieve significant improvements through a high cadence of RIEs</p>	<p>Transition from teaching Breakthrough certification Levels 3 and 4 (Silver and Gold), continue to teach Level 5 (Platinum)</p> <p>Coach Leadership, Executive Sponsors, Steering Committees on event architecture and processes</p>	<p>Teach certification Levels 1 and 2 (Green and Bronze), complete takeover of teaching Level 3 (Silver)</p> <p>Train Process Owners, facilitate RIEs and other events</p>
<p>ENABLE WIDER APPLICATION OF BREAKTHROUGH</p> <p>Provide the means for engagement of the larger workforce in daily improvement activities</p>		<p>Develop and implement additional training modules, expand awareness, continue to provide Problem Solving, A3 and other targeted workshops</p>

Collaborated and Coordinated Action

OBJECTIVE	SIMPLER ROLE	HHC ROLE
SUSTAIN IMPROVEMENTS Enable managers to implement and sustain the improvement system	Coach and teach Managing for Daily Improvement	Develop the HHC MDI program, develop internal coaching and teaching capacity
CREATE MODELS Maximize improvement opportunity by identifying the 'best known way today'	Coach the development of model value streams and cells, including in Peri-operative Services	Learn how to coach and develop model value streams and cells, implement at all sites
SPREAD SUCCESSES Share improvements across sites and across the Corporation	Coach yokoten (spread), support the development of HHC's yokoten system	Develop the yokoten system, learn to coach yokoten, develop model value streams and cells at all sites
SPREAD TO ADDITIONAL SITES Continue to seek full implementation	Coach adoption of Breakthrough at East New York D&TC and Susan Smith McKinney NRC	Provide launch support to these two sites
MONITOR PROGRESS OF IMPROVEMENT CAPABILITY Move forward, guard against backsliding	Conduct reviews of each site at least twice a year.	Participate in reviews, develop corrective action plans and establish interim improvement and process goals Learn to conduct reviews

Spending Plan for Future Years

- Reduce future annual contract spend
 - Year 7: reduce by 25% over Year 6 spend
 - Year 8: reduce by an additional 25% over Year 7 spend
 - Year 9: review ongoing needs
- Enable this spending reduction through
 - embedding expertise throughout the organization
 - intensive training of leaders, managers and staff
 - implementation of manager's improvement system
 - continued development of model cells and value streams
 - active engagement of enterprise steering committee
 - alignment between enterprise transformation plan (TPOC) and business priorities (hoshin kanri)

RESOLUTION

Authorizing the President of the New York City Health and Hospitals Corporation (the "Corporation") to execute a requirements contract with Nirman Construction, Inc. (the "Contractor") for a cumulative amount not-to-exceed \$5,000,000 to provide construction services for General Construction Work on an as-needed basis at various facilities throughout the Corporation.

WHEREAS, the facilities of the Corporation may require construction services for General Construction Work; and

WHEREAS, the Corporation has determined that the needs of the Networks for these services can be best met by utilizing outside firms, on an as-needed basis through a requirements contract; and

WHEREAS, the Corporation's Operating Procedure No. 100-5 requires approval by the Board of Directors of competitively bid contracts having a bid price greater than \$3,000,000; and

WHEREAS, bids were publicly opened on May 2, 2012 and the Corporation has determined that the Contractor is the lowest responsible bidder for this contract; and

WHEREAS, the Contractor has met all, legal, business and technical requirements and is qualified to perform the services as required in the contract documents.

NOW, THEREFORE, be it

RESOLVED that the President of the New York City Health and Hospitals Corporation (the "Corporation") be and hereby is authorized to execute a contract with Nirman Construction, Inc. (the "Contractor") to provide construction services for General Construction Work on an as-needed basis at various facilities throughout the Corporation. The contract shall be for a term of two (2) years, for a cumulative amount not to exceed \$5,000,000 for the services provided by this contractor.

**EXECUTIVE SUMMARY
REQUIREMENTS CONTRACT**

NIRMAN CONSTRUCTION, INC.

OVERVIEW: The Corporation seeks to execute a two (2)-year contract not to exceed \$5,000,000 for construction services to be performed on an as needed basis/on demand, at any of its facilities. This method of requirements contract establishes a pre-fixed pricing for materials comprised of thousands of items utilized within a typical renovation project. The successful lowest responsible bidder submits its proposal based upon acceptance of the pre-fixed materials pricing, and its unique submission of a labor multiplier to install the pre-fixed materials. This labor multiplier is referred to as a "factor". Thus, if a material to be installed is \$10.00, and the contractor's factor to install that material is 1.0, the cost for that material and labor is \$10.00, inclusive of overhead and profit. Under this format, the contractor is pre-qualified to perform work on an as needed/on demand basis for projects of varying size and for any trade required to complete the project.

This format has been used in previous HHC requirements contracts, and continues to be used by the New York City School Construction Authority ("SCA"), the New York State Dormitory Authority ("DASNY"), the New York City Department of Design and Construction, ("DDC"), the New York City Department of Environmental Protection ("DEP"), the United States Postal Service ("UPS"), and others. The program was developed by the Department of Defense and has been in existence for more than twenty years.

NEED: Facilities sometimes require construction services that fluctuate in frequency, vary in size and urgency, which cannot be timely and cost effectively be completed through a dedicated design, bid and award process.

TERMS: The construction services will be provided via a work order system within a two year period not to exceed \$5,000,000.

FINANCING: Requirements contracts provide a pre-qualified approved mechanism for Networks to access construction services. Networks establish funding source such as capital funds from bond proceeds, expense (OTPS), or other funding sources such as grants.

SCHEDULE: Upon contract execution, this contract shall be in effect for a two (2) year period or until the funds have been exhausted, whichever comes first.

**CONTRACT FACT SHEET
REQUIREMENTS CONTRACT**

**NIRMAN CONSTRUCTION, INC.
CONSTRUCTION SERVICES FOR GENERAL CONSTRUCTION WORK**

CONTRACT SCOPE: Construction Services for General Construction Work

CONTRACT DURATION: 2 Years

ADVERTISING PERIOD: March 29, 2012 to April 24, 2012

BID DOCUMENTS ISSUED: Thirty-Two (32) Prime Contractors

BIDS RECEIVED: Fourteen (14) Bids Received

**LOWEST THREE (3)
CONTRACTOR
MULTIPLIERS:**

Nirman Construction, Inc.	0.6915
Gridspan Corporation	0.7075
Atlas Restoration Corporation	0.7150

**LOWEST RESPONSIVE/
RESPONSIBLE BIDDER:** Nirman Construction, Inc.
34-30 75th Street
Jackson Heights, NY 11372

**CONTRACTOR'S SIMILAR
EXPERIENCE:**

NYCHHC - Bellevue Hospital Center
Neo-Natal Intensive Care Unit
General Construction Work
Completed: 2010
Amount: \$ 1,444,400

NYCHHC - Harlem Hospital Center
Hospital Police relocation
General Construction
Completed: 2010
Amount: \$594,400

NYCHHC – Woodhull Medical & Mental Health Ctr.
Women's Option Center
General Construction Work
Completed: 2011
Amount: \$594,000

CONTRACT AMOUNT: \$5,000,000

VENDEX/EEO APPROVAL: Approved

Office of Legal Affairs

MEMORANDUM

To: Clifton S. McLaughlin
Office of Facilities Development

From: Karen Rosen 
Assistant Director

Date: September 7, 2012

Subject: VENDEX Approval

For your information, on September 7, 2012 approval was granted by the Office of Legal Affairs for the following company:

Nirman Construction , Inc.

cc: Norman M. Dion, Esq.

Manasses C. Williams
Assistant Vice President
Affirmative Action/EEO

manasses.williams@nychhc.org

TO: Clifton S. Mc Laughlin
Sr. Management Consultant
Office of Facilities Development

FROM: Manasses Williams 

DATE: August 16, 2012

SUBJECT: EEO CONTRACT COMPLIANCE REVIEW AND EVALUATION

The proposed contractor/consultant, Nirman Construction, Inc., has submitted to the Affirmative Action Office a completed Contract Compliance Questionnaire and the appropriate EEO documents.

This company is a:

Minority Business Enterprise Woman Business Enterprise Non-M/WBE

Project Location (s): HHC – Corporate Wide

Project Number: 11-IQGC-3

Provide: Indefinite Quantity Construction Services

Submitted by: Office of Facilities Development

EEO STATUS:

1. Approved
2. Approved with follow-up review and monitoring
3. Not Approved
4. Subject to EEO Committee Review

COMMENTS:

MCW:moe

c:

RESOLUTION

Authorizing the President of the New York City Health and Hospitals Corporation (the "Corporation") to execute a lease agreement with 160 Water Street Associates (the "Landlord"), for the Corporation's rental of space at 160 Water Street, Borough of Manhattan, to house Corporation staff.

WHEREAS, as part of a broader initiative to reduce the amount of office space owned by the City of New York (the "City") by 1.2 million square feet by 2014, the New York City Department of Citywide Administrative Services ("DCAS") and the New York City Economic Development Corporation ("EDC") have issued a Request-for-Proposals ("RFP") for the sale of 346 Broadway and two other properties located in lower Manhattan; and

WHEREAS, the RFP calls for the space occupied by the Corporation at 346 Broadway in Manhattan to be vacated by early 2014 and to accommodate the City's disposition plans, the Corporation is seeking space to house its staff now occupying 346 Broadway;

WHEREAS, the Corporation's Enterprise Information Technology Services unit ("EITS") is involved in several Corporate-wide initiatives, including the Electronic Medical Records project, which require an increase in the size of its staff currently housed at several locations; and

WHEREAS, it is imperative that space for EITS staff be available immediately; and

WHEREAS, the increase in the EITS unit and the need to relocate staff from 346 Broadway combine to create a need for the Corporation to rent privately owned office space; and

WHEREAS, pursuant to a separate resolution the Corporation will rent approximately 131,000 square feet of office space above ground and approximately 76,000 square feet of office space below grade at 55 Water Street in lower Manhattan but such space will not be ready for occupancy until early 2014 ; and

WHEREAS, the Corporation now occupies approximately 291,000 square feet of space at 160 Water Street, and acquiring one (1) additional floor in the building will provide space to satisfy the immediate space needs of EITS.

NOW, THEREFORE, be it

RESOLVED, that the President of the New York City Health and Hospitals Corporation (the "Corporation") be and hereby is authorized to execute a lease with 160 Water Street Associates (the "Landlord"), for the Corporation's rental of space at 160 Water Street, Borough of Manhattan, to house the Corporation's staff.

The Corporation shall have use and occupancy of a total of approximately 20,600 square feet of space located on the 13th floor at 160 Water Street (the "Demised Premises"). The term of the lease agreement shall be three (3) years commencing November 1, 2012 and ending December 31, 2015. The base rent for the initial term shall be \$26.50 per square foot, or approximately \$545,900 per year. The rent

Page 2 – Resolution
160 Water Street Associates

shall commence November 1, 2012. The lease shall contain one three year option to renew and one five year option to renew exclusive to the Tenant.

The space the Corporation will lease at 55 Water Street will house staff now located at 346 Broadway and EITS staff located in several locations and new EITS staff. However, the 55 Water St. space will not be ready for occupancy until early in 2014. The space at 160 Water Street will satisfy EITS' immediate need for space to house up to 120 new employees. The Corporation has no space suitable to meet this requirement and was unable, after diligent search, to find space to rent for a shorter period than is proposed at 160 Water Street. The 20,600 square feet on the 13th floor requires minimal renovation and can be ready for EITS use by early December 2012. It is anticipated that the Corporation will make other good use of the 13th Floor space at 160 Water Street as swing space as it vacates various other locations to ultimately fully occupy 55 Water Street

The Landlord shall supply to the Demised Premises hot and cold water, heating, ventilation and air conditioning. The Landlord shall be responsible for building maintenance and structural repairs, including the roof, utility supply lines, and common areas including curbs and sidewalks.

The electricity provided to the Demised Premises shall be submetered. The Tenant shall be entitled to benefit from a discounted electrical rate made available through the New York State Power Authority ("NYPA"). The Landlord, at its own expense, shall provide electrical connections required for connection to NYPA power.

The Corporation shall pay its proportionate share of real estate tax increases above the average for fiscal years 2012/2013 – 2013/2014. The Corporation shall also pay its proportionate share of operating expense increases above the 2013 base year.

The Landlord shall perform Tenant Finish Work in a good workmanlike manner in accordance with plans and specifications provided by the Corporation. The estimated cost of the Tenant Finish Work, to be paid by the Corporation, shall not exceed \$1.2 million including a 10% contingency for additional work authorized by the Corporation. Payment for the work shall be due upon substantial completion and acceptance by the Corporation.

EXECUTIVE SUMMARY

LEASE AGREEMENT 160 WATER STREET ASSOCIATES

OVERVIEW: The President seeks authorization from the Board of Directors to execute a lease agreement with 160 Water Street Associates (the "Landlord"), for the Corporation's rental of space at 160 Water Street, Borough of Manhattan, to house the Corporation's Enterprise Information Technology Services unit ("EITS") staff.

**NEED/
PROGRAM:** As part of a broader initiative to reduce the amount of office space owned by the City of New York (the "City") by 1.2 million square feet by 2014, the New York City Department of Citywide Administrative Services ("DCAS") and the New York City Economic Development Corporation ("EDC") have issued a Request-for-Proposals ("RFP") for the sale of 346 Broadway in Manhattan and two other properties located in lower Manhattan. The RFP calls for the space occupied by the Corporation in 346 Broadway to be vacated by early 2014. To accommodate the City's disposition plans, the Corporation is seeking space to house its staff now occupying 346 Broadway. EITS is involved in several corporate-wide initiatives, including the Electronic Medical Records project which requires an increase in the size of its existing staff currently housed at several locations. The Corporation now occupies approximately 291,000 square feet of space at 160 Water Street, acquiring one (1) additional floor in the building will provide space to satisfy the immediate space needs of EITS' new employees.

By the middle of 2014 all of the EITS staff will be located in space the Corporation will rent at 55 Water Street in lower Manhattan. The 13th Floor at 160 Water Street will serve as swing space until the 55 Water Street space is ready and will accommodate the new EITS employees who must start work immediately to achieve the Corporation's objectives for the implementation of its new Electronic Medical Records initiatives. The Corporation is presently evaluating its immediate and long-term needs and may utilize the 13th floor to meet those needs after EITS relocates to 55 Water Street.

TERMS: The Corporation will have the use and occupancy of a total of approximately 20,600 square feet of space located on the 13th floor at 160 Water Street (the "Demised Premises"). The term of the lease agreement will be three (3) years commencing November 1, 2012 and ending December 31, 2015. The base rent for the initial term will be \$26.50 per square foot, or approximately \$545,900 per year. The rent will commence November 1, 2012. The lease will contain one three year option to renew and one five year option to renew exclusive to the Tenant.

The Landlord will supply to the Demised Premises hot and cold water, heating, ventilation and air conditioning. The Landlord will be responsible for building

maintenance and structural repairs, including the roof, utility supply lines, and common areas including curbs and sidewalks.

The electricity provided to the Demised Premises will be submetered. The Corporation will be entitled to benefit from a discounted electrical rate made available through the New York State Power Authority (“NYPA”). The Landlord, at its own expense, will provide electrical connections required for NYPA power. The Corporation shall pay its proportionate share of real estate tax increases above the average for fiscal years 2012/2013 – 2013/2014. The Corporation shall also pay its proportionate share of operating expense increases above the 2013 base year.

The Landlord shall perform Tenant Finish Work in accordance with plans and specifications provided by the Corporation. The estimated cost of the Tenant Finish Work, to be paid by the Corporation, shall not exceed \$1.2 million including a 10% contingency for additional work authorized by the Corporation. Payment for the work shall be due upon substantial completion and acceptance by the Corporation.

SUMMARY OF ECONOMIC TERMS

SITE:	160 Water Street Borough of Manhattan
SIZE:	20,600 square feet
LANDLORD:	160 Water Street Associates
TERM:	Three (3) years
RENT:	\$26.50 per square foot for the initial term, \$26.50 per square foot for the three year renewal option term, \$29.00 per square foot for the five year option term
RENEWAL OPTION:	One (1) three year option, one (1) five year option
MAINTENANCE:	The Landlord is responsible for building maintenance and structural repairs.
UTILITIES:	The Landlord will supply hot and cold water, heating, ventilation and air conditioning. Electricity will be sub-metered and the tenant will be entitled to NYPA rates.
REAL ESTATE TAXES:	The Corporation will pay its proportionate share of real estate tax increases above the average for fiscal years 2012/2013 – 2013/2014.
OPERATING EXPENSES:	The Corporation will pay its proportionate share of operating expense increases above the 2013 base year.

**NYC HEALTH & HOSPITAL CORP.
COMPARABLE LEASE TRANSACTIONS
160 WATER STREET**

160 WATER STREET

The pending renewal at 160 Water Street is based on the following terms:

Because of the short-term nature of the renewal, concessions were not provided by the landlord, and their value was 'netted out' of the base rent to provide a market-comparable transaction. (Also—see note under 55 Water Street regarding the inclusion of free rent.)

Address	Tenant	Floor Area (sf)	Lease Term (yrs)	Free Rent (Months)	Work Letter (psf)	Rent (psf)	Net Effective Rent (psf)
160 Water St.	HHC	20,600	3	None	None	\$26.50	\$26.50

160 Water Street Comparable Lease Transactions

The transactions listed below were recently completed in Class B properties that could be considered comparable in quality, location or other factors to 160 Water Street.

Address	Tenant	Floor Area (sf)	Lease Term (yrs)	Free Rent (Months)	Work Letter (psf)	Rent (psf)	Net Effective Rent (psf)
One Battery Park Plaza	World Education Svc	25,860	10	6	n/a	\$34/5, \$38/5	\$33.59
80 Broad St.	McGivney & Kluger	22,992	10	6	\$20	\$31/3, \$33/3, \$36/4	\$28.50
160 Water St.	Seneca Insurance	21,500	8	6	\$7.50	\$26.50, \$29.50	\$24.73
Two Rector St.	Barry McTiernan et al	18,000	10	11	\$50	\$29.50/5, \$32.50/5	\$21.12

Comments:

World Education Service/One Battery Park Plaza: The building is very comparable in design and character to 160 Water Street, down to the fact that the construction is of the same type with a similar dark glass & metal-frame curtain wall. One Battery Park Plaza, however, is arguably better located, and features excellent views of the New York City harbor. The ownership is one of the city's most highly-regarded landlords, and the low debt on the building has enabled the owner to structure competitive deals.

McGivney & Kluger/80 Broad Street: The property is a centrally-located prewar with mid-sized base floors and small tower floors. The space in question was leased with an existing installation that had a high residual value, allowing the incoming tenant to move in without a complete re-build.

Seneca Insurance/160 Water Street: This transaction was a renewal with a long-time tenant. While the rent was lower than those in comparable properties, the concessions were also low.

Barry McTiernan/2 Rector Street: The property is a large-floorplate pre-war located immediately behind Trinity Church. The building has recently undergone renovations, and while the location is not 'prime', it is convenient to numerous subway lines. Note that concessions are comparable to properties achieving much higher base rents.

Conclusion:

The market comparables presented indicate the proposed lease is fair and reasonable.

RESOLUTION

Authorizing the President of the New York City Health and Hospitals Corporation (the "Corporation") to execute a lease agreement with New Water Street Corporation (the "Landlord"), for the Corporation's rental of space at 55 Water Street, Borough of Manhattan, to house the Corporation's staff.

WHEREAS, as part of a broader initiative to reduce the amount of office space owned by the City of New York (the "City") by 1.2 million square feet by 2014, the New York City Department of Citywide Administrative Services ("DCAS") and the New York City Economic Development Corporation ("EDC") have issued a Request-for-Proposals ("RFP") for the sale of 346 Broadway and two other properties located in lower Manhattan; and

WHEREAS, the RFP calls for the space occupied by the Corporation to be vacated by early 2014 and to accommodate the City's disposition plans, the Corporation initiated a search for space to house its staff now occupying 346 Broadway and, after evaluating several alternative options for housing corporate staff, determined that 55 Water Street offered the best solution for meeting its space requirements; and

WHEREAS, in addition to the staff located at 346 Broadway, the Corporation's Enterprise Information Technology Services unit ("EITS") shall relocate staff from several locations to 55 Water Street.

NOW, THEREFORE, be it

RESOLVED, that the President of the New York City Health and Hospitals Corporation (the "Corporation") be and hereby is authorized to execute a lease agreement with New Water Street Corporation (the "Landlord"), for the Corporation's rental of space at 55 Water Street, Borough of Manhattan, to house Corporation staff.

The Corporation shall have use and occupancy of a total of approximately 207,507 square feet of space located on the 25th, 26th, Concourse and Sublevel 1 floors at 55 Water Street (the "Demised Premises"). The term of the lease agreement shall be twenty (20) years commencing upon substantial completion of certain Landlord work estimated to occur approximately December 1, 2013. Lease expiration would be approximately December 31, 2033. The rent shall commence December 1, 2013. The base rent for lease years 1-5 shall be approximately \$5,833,190 per year, for years 6-10 approximately \$6,510,462, approximately \$7,187,734 for lease years 11-15, and approximately 7,865,006 for lease years 16-20. The base rent per square foot shall be as shown in the table below.

	Years 1-5	Years 6-10	Years 11-15	Years 16-20
Floors 25, 26	\$34.00	\$38.00	\$42.00	\$46.00
Concourse, Sublevel 1	\$18.00	\$20.00	\$22.00	\$24.00

The Landlord shall supply to the Demised Premises hot and cold water, heating, ventilation and air conditioning. The Landlord shall be responsible for building maintenance and structural repairs, including the roof, utility supply lines, and common areas including curbs and sidewalks.

**Page Two – Resolution
55 Water Street Corporation**

The electricity provided to the Demised Premises shall be sub-metered. The Tenant shall be entitled to benefit from a discounted electrical rate made available through the New York State Power Authority ("NYPA"). The Landlord, at its own expense, shall provide electrical connections required for access to NYPA power.

The Corporation shall pay its proportionate share of real estate tax increases above the average for fiscal years 2013/2014 – 2015/2015. The Corporation shall also pay its proportionate share of operating expense increases above the 2014 base year.

The Landlord shall perform Tenant Finish Work in accordance with plans and specifications provided by the Corporation. The estimated cost of the Tenant Finish Work, to be paid by the Corporation, shall not exceed approximately \$18.4M.

The leased floors are structured as condominium units with separate block and lot numbers. The Corporation's enabling act provides for an exemption from payment of real estate when it controls an entire property. Because of the unusual ownership structure of 55 Water Street, the Corporation has an unusual opportunity to assert an argument for exempting those parts of 55 Water Street where it occupies entire floors, i.e. the 25th and 26th floors but not the space on the Concourse or Sublevel 1 floors. It is not clear if the Corporation will prevail with the New York City Department of Finance in advancing this argument. If it is successful, the real estate taxes saved would be approximately \$6.00 per square foot and the Landlord has agreed that such savings would be passed through to the Corporation in reduced rent on the 25th and 26th floors thereby bringing the initial rent down from \$34.00 per square foot to \$28.00 per square foot.

EXECUTIVE SUMMARY

LEASE AGREEMENT NEW WATER STREET CORPORATION

OVERVIEW: The President seeks authorization from the Board of Directors to execute a lease agreement with New Water Street Corporation (the "Landlord"), for the Corporation's rental of space at 55 Water Street, Borough of Manhattan, to house Corporation staff.

**NEED/
PROGRAM:**

As part of a broader initiative to reduce the amount of office space owned by the City of New York (the "City") by 1.2 million square feet by 2014, the New York City Department of Citywide Administrative Services ("DCAS") and the New York City Economic Development Corporation ("EDC") have issued a Request-for-Proposals ("RFP") for the sale of 346 Broadway and two other properties located in lower Manhattan. The RFP calls for the space occupied by the Corporation in 346 Broadway to be vacated by early 2014. To accommodate the City's disposition plans, the Corporation initiated a search for space to house its staff now occupying 346 Broadway. In addition to the staff located at 346 Broadway, the Corporation's Enterprise Information Technology Services ("EITS") will relocate staff from several locations to 55 Water Street. After evaluating several alternative options for housing corporate staff, the Corporation determined that 55 Water Street offered the best solution for meeting the Corporation's space requirements.

The Corporation now occupies approximately 133,480 square feet of space on eight (8) floors at 346 Broadway. It is anticipated that the three hundred and twenty-five (325) employees located in the building shall be relocated to 55 Water Street. EITS staff presently occupies a total of approximately 66,000 square feet of space at 160 Water Street, 33 Whitehall Street, and Jacobi Medical Center. Over the next five years, the EITS will be tasked with major Corporate initiatives including: the acquisition, development and implementation of a new Electronic Medical Record system; building and deploying a business intelligence strategy and system for better reporting and decision support; planning and implementing a new payroll and time keeping system; planning and implementing a new financial accounting system; and continuing with the consolidation of IT services throughout the Corporation. The execution of these initiatives and others requires an increase in permanent staff, supplemented by a significant number of temporary staff, including consultants, to augment the Corporation's internal resources. At the peak, EITS will need space to seat approximately an additional 150-200 staff to work on three projects. It is anticipated that four hundred and forty-seven (447) EITS employees will be relocated to 55 Water Street.

**Page Two – Executive Summary
New Water Street Corporation**

TERMS: The Corporation will have use and occupancy of a total of approximately 207,507 square feet of space located on the 25th, 26th, Concourse and Sublevel 1 floors at 55 Water Street. The term of the lease agreement will be twenty (20) years commencing approximately December 1, 2013 and ending approximately December 31, 2033. The rent will commence December 1, 2013. The base rent for lease years 1-5 will be approximately \$5,833,190 per year, for years 6-10 approximately \$6,510,462, approximately \$7,187,734 for lease years 11-15, and approximately 7,865,006 for lease years 16-20.

The Landlord will perform Tenant Finish Work in accordance with plans and specifications provided by the Corporation. The estimated cost of the Tenant Finish Work, to be paid by the Corporation, will not exceed approximately \$18.4M. The lease will not commence until this Tenant Finish Work is completed.

The Landlord will supply to the Demised Premises hot and cold water, heating, ventilation and air conditioning. The Landlord will be responsible for building maintenance and structural repairs, including the roof, utility supply lines, and common areas including curbs and sidewalks.

The electricity provided to the Demised Premises will be sub-metered. The Tenant will be entitled to benefit from a discounted electrical rate made available through the New York State Power Authority ("NYPA"). The Landlord, at its own expense, will provide electrical connections required for access to NYPA power.

The Corporation will pay its proportionate share of real estate tax increases above the average for fiscal years 2013/2014 – 2015/2015. The Corporation will also pay its proportionate share of operating expense increases above the 2014 base year.

The leased floors are structured as condominium units with separate block and lot numbers. The Corporation's enabling act provides for an exemption from payment of real estate when it controls an entire property. Because of the unusual ownership structure of 55 Water Street, the Corporation has an unusual opportunity to assert an argument for exempting those parts of 55 Water Street where it occupies entire floors, i.e. the 25th and 26th floors but not the space on the Concourse or Sublevel 1 floors. It is not clear if the Corporation will prevail with the New York City Department of Finance in advancing this argument. If it is successful, the real estate taxes saved would be approximately \$6.00 per square foot and the Landlord has agreed that such savings would be passed through to the Corporation in reduced rent on the 25th and 26th floors thereby bringing the initial rent down from \$34.00 per square foot to \$28.00 per square foot.

SUMMARY OF ECONOMIC TERMS

- SITE:** 55 Water Street
Borough of Manhattan
- SIZE:** Approximately 207,507 square feet
- LANDLORD:** New Water Street Corporation
- TERM:** 20 years
- RENT:** Floors 25, 26: \$34 per square foot, \$38 per square foot, \$42 per square foot, and \$46 per square foot
Concourse, Sublevel 1: \$18 per square foot, \$20 per square foot, \$22 per square foot and \$24 per square foot
- MAINTENANCE:** The landlord is responsible for building maintenance and structural repairs.
- UTILITIES:** The landlord will supply hot and cold water, heating, ventilation and air conditioning. Electricity will be sub-metered and the Corporation will be entitled to NYPA rates.
- REAL ESTATE TAXES:** The Corporation will pay its proportionate share of real estate tax increases above the average for fiscal years 2013/2014 – 2014/2015. The leased floors are structured as condominium units with separate block and lot numbers. The Corporation's enabling act provides for an exemption from payment of real estate when it controls an entire property. If the Corporation is successful in exempting the 25th and 26th floors from real estate tax, the initial rent for such floors will be reduced from \$34.00 per square foot to \$28.00 per square foot. Further, the Corporation will escape exposure to any tax escalation for those floors.
- OPERATING EXPENSES:** The Corporation shall pay its proportionate share of operating expense increases above the 2014 base year.

Year	1	2	3	4	5	Total yrs 1-5	6	7	8	9	10	Total yrs 6-10	11	12	13	14	15	Total yrs 11-15	16	17	18	19	20	Total yrs 16-20	Total yrs 1-20						
Floor	RSF																														
26	64,971	2,209,014	2,209,014	2,209,014	2,209,014	2,209,014	2,209,014	2,209,014	2,209,014	2,209,014	2,209,014	11,045,070	2,458,898	2,458,898	2,458,898	2,458,898	2,458,898	12,544,890	2,728,782	2,728,782	2,728,782	2,728,782	2,728,782	13,643,910	2,988,666	2,988,666	2,988,666	2,988,666	2,988,666	14,943,330	51,976,800
28	66,154	2,249,372	2,249,372	2,249,372	2,249,372	2,249,372	2,249,372	2,249,372	2,249,372	2,249,372	2,249,372	11,248,660	2,514,004	2,514,004	2,514,004	2,514,004	2,514,004	12,570,020	2,778,636	2,778,636	2,778,636	2,778,636	2,778,636	13,693,180	3,043,268	3,043,268	3,043,268	3,043,268	3,043,268	15,216,340	52,926,400
Concourse	27,164	488,952	488,952	488,952	488,952	488,952	2,444,760	543,260	543,260	543,260	543,260	543,260	2,716,400	597,608	597,608	597,608	597,608	2,968,040	651,936	651,936	651,936	651,936	651,936	3,259,680	3,259,680	3,259,680	3,259,680	3,259,680	11,403,840	11,403,840	
Sub 1	49,214	885,652	885,652	885,652	885,652	885,652	4,479,260	984,260	984,260	984,260	984,260	984,260	4,921,400	1,082,708	1,082,708	1,082,708	1,082,708	5,413,540	1,181,136	1,181,136	1,181,136	1,181,136	1,181,136	5,905,680	5,905,680	5,905,680	5,905,680	5,905,680	20,669,880	20,669,880	
Total	207,501	5,833,190	5,833,190	5,833,190	5,833,190	5,833,190	29,169,960	6,510,462	6,510,462	6,510,462	6,510,462	6,510,462	32,552,310	7,167,734	7,167,734	7,167,734	7,167,734	35,038,670	7,685,006	7,685,006	7,685,006	7,685,006	7,685,006	38,325,030	38,325,030	38,325,030	38,325,030	38,325,030	135,981,960	135,981,960	

Rent floors 25, 26 \$34-\$38-\$42-\$46
 Rent Concourse, Sub 1 \$18-\$20-\$22-\$24

**NYC HEALTH & HOSPITAL CORP.
COMPARABLE LEASE TRANSACTIONS
55 WATER STREET**

55 WATER STREET

The comparable lease transactions on the tables below represent relevant recent transactions against which the pending HHC transaction can be compared to evaluate the lease terms in a market context. Factors to consider: Building age, location, infrastructure, market status. Additionally, leases should be viewed in the total context of all of the financial variables, including Base rent, rent concessions (free rent), tenant improvements, and length of term. All lease terms listed represent final negotiated terms.

Address	Tenant	Floor Area (sf)	Lease Term (yrs)	Free Rent (Months)	Work Letter (psf)	Rent (psf)	Net Effective Rent (psf)
55 Water Street	HHC	131,129	20.92	11	\$50	34/5, \$38/5, \$42/5, \$46/5	\$32.26

The terms outlined above do not include the below-grade space incorporated into HHC's acquisition. The below-grade space at 55 Water Street is fairly unique among Downtown buildings, in that it is full-service office space, comparable to normal office floors in every way except for the lack of windows. The rule of thumb for below-grade space is that rental rates run +/-50% of the applicable rate for office space, with no escalations and a tenant-improvement allowance only sufficient to construct the space as storage, mailroom or other sparsely-populated use. As HHC is receiving a concession package comparable to a typical office deal, and the landlord is providing full services, its proposed lease includes normal escalations.

NOTE: The above terms indicate a rent concession of 11 months. Whereas HHC's proposed transaction does not incorporate a free rent allowance, one is imputed from the landlord's perspective and is included herein for analytical purposes to create an apples-to-apples comparison with the properties discussed below.

55 Water Street Comparable Lease Transactions

The transactions listed below have been recently completed in properties which are reasonably comparable in quality to 55 Water Street. These properties are either Class A, or very well-located Class B buildings.

Address	Tenant	Floor Area (sf)	Lease Term (yrs)	Free Rent (Months)	Work Letter (psf)	Rent (psf)	Net Effective Rent (psf)
200 Hudson St.	Havas	226,000	15	12	\$60	\$40/5, \$44/5, \$47/5	\$33.72
75 Park Place	OMB	205,000	15	6	\$5	\$34/5, \$37/5, \$40/5	\$34.37
33 Whitehall St.	Fitch Investor Svc	180,519	16	12	\$80	\$39/5, \$44/5, \$49/5	\$32.11
14 Wall St.	Amerigroup	165,029	10	5	\$65	\$31/3, \$35.50/4, \$39/3	\$24.91
One Liberty Plz	ITG	132,092	16	12	\$65	\$44/5, \$49/5, \$54/5	\$38.03
22 Cortlandt St.	MCU	126,715	15	9	\$15	\$33.90/5, \$37.20/5, \$41.02	\$33.01

Comments:

Havas/200 Hudson Street: This European advertising conglomerate considered all of the major Manhattan markets before settling on relocating the entirety of its operations to the Hudson Square area. 200 Hudson Street is a pre-war light-industrial building with 35,000 RSF floorplates. The property has recently undergone a total building renovation, converting all of the remaining industrial space to office use, including the installation of new building systems.

OMB/75 Park Place: 75 Park Place is a 1980's-vintage property featuring floorplates that are ideally suited for back-office operations. At one time, the location was considered secondary, but with the redevelopment of the World Trade Center, and the evolution of Tribeca as one of Manhattan's most popular upscale residential neighborhoods, the Building's location has to be re-evaluated as primary.

Fitch Investor Service/33 Whitehall Street: This property was developed in the 1980's, and like 55 Water Street, is known for its robust infrastructure. The floorplates, however (averaging +/-20,000SF), are considered smaller than ideal for major institutional users.

Amerigroup/14 Wall Street: This property is a primary pre-war, and considered Class A largely because of its central location. The base floors are large and suitable for institutional use, although infrastructure is typical for a pre-war property. Note that the base rents represent the low end of the scale for this set, while concessions remain comparable to buildings achieving higher rents.

ITG/One Liberty Plaza: One Liberty Plaza is considered one of Lower Manhattan's higher-quality properties, and has long been home to some of the City's prominent financial institutions. The subject floors for this transactions are lower in the building's stack, and lack the exceptional views that are available on higher floors. The floorplates are large, open and highly efficient.

MCU/22 Cortland Street: This property is considered a high Class-B location. The building is typical of 1970's design and infrastructure, and although the location is very central and convenient to public transportation, Cortlandt Street has no "cache" value, and the floorplates are unexceptional. The building's ground floor is home to the retailer Century 21. This transaction was a renewal and expansion.

Conclusion:

The market comparables presented indicate the proposed lease is fair and reasonable.

RESOLUTION

Authorizing the amendment of the resolutions adopted by the Board of Directors of the New York City Health and Hospitals Corporation (the "Corporation") on September 27, 2012 that authorized the creation of the HHC Finance Corporation, the participation of the Corporation in a certain set of transactions to secure supplemental financing for the Harlem Hospital Modernization project and to authorize the directors of the HHC Finance Corporation to also authorize the participation of the HHC Finance Corporation in such transactions (the "resolutions") so as to replace in the Resolutions all references made to the HHC Finance Corporation with references to the HHC Assistance Corporation and ratifying the actions taken to form the HHC Assistance Corporation.

WHEREAS, on September 27, 2012 the Board of Directors of the New York City Health and Hospitals Corporation (the "Corporation") adopted the resolutions attached hereto (the "Resolutions"); and

WHEREAS, due to objections of the Secretary of State of the State of New York it was not possible to form the HHC Finance Corporation as contemplated by the Resolutions; and

WHEREAS, to carry out the intentions of the Resolutions, instead of the HHC Finance Corporation, a corporation was formed under the name, "HHC Assistance Corporation" that has substantially the rights, powers and characteristics as had been planned for the HHC Finance Corporation; and

WHEREAS, to carry out the intentions of the Resolutions in light of the formation of HHC Assistance Corporation instead of HHC Finance Corporation, it is necessary, to amend the Resolutions as provided below.

NOW, THEREFORE, be it

RESOLVED, that all references made in the Resolutions to the HHC Finance Corporation be hereby deemed replaced with references to the HHC Assistance Corporation; and it is further

RESOLVED, that the certificate of incorporation and the by-laws of the HHC Finance Corporation that had been attached to the Resolutions be hereby deemed replaced with the certificate of incorporation and the by-laws of HHC Assistance Corporation; and it is further

RESOLVED, that all actions taken by the officers, employees and agents of the Corporation to cause the incorporation of the HHC Assistance Corporation are hereby ratified and confirmed as the valid acts of the Corporation.

FILING RECEIPT

=====

ENTITY NAME: HHC ASSISTANCE CORPORATION

DOCUMENT TYPE: INCORPORATION (NOT-FOR-PROFIT)

TYPE: C COUNTY: NEWY

=====

FILED:10/05/2012 DURATION:PERPETUAL CASH#:121005001311 FILM #:121005001248

FILER:

EXIST DATE

KATTEN MUCHIN ROSENMAN LLP
575 MADISON AVE

10/05/2012

NEW YORK, NY 10022

ADDRESS FOR PROCESS:

SENIOR VICE PRESIDENT OF LEGAL AFFAIRS, NEW YORK CITY HEALTH
AND HOSPITALS CORPORATION 125 WORTH ST., RM. 527
NEW YORK, NY 10013

REGISTERED AGENT:

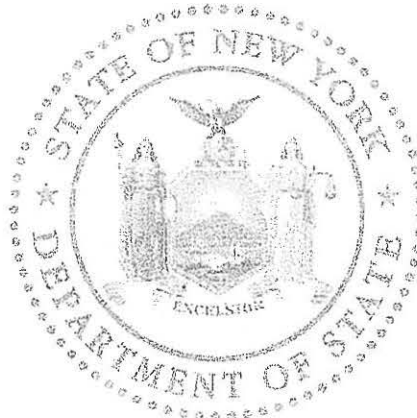

=====

SERVICE COMPANY: CORPORATION SERVICE COMPANY - 45

SERVICE CODE: 45

FEEs 385.00

FILING 75.00
TAX 0.00
CERT 0.00
COPIES 10.00
HANDLING 300.00

PAYMENTS 385.00

CASH 0.00
CHECK 0.00
CHARGE 0.00
DRAWDOWN 385.00
OPAL 0.00
REFUND 0.00

=====

362969SNE

DOS-1025 (04/2007)

STATE OF NEW YORK

DEPARTMENT OF STATE

I hereby certify that the annexed copy has been compared with the original document in the custody of the Secretary of State and that the same is a true copy of said original.



WITNESS my hand and official seal of the Department of State, at the City of Albany, on October 5, 2012.

A handwritten signature in black ink, appearing to read "Daniel E. Shapiro".

Daniel E. Shapiro
First Deputy Secretary of State

121005001248

CSC 45
DRAW DOWN

CERTIFICATE OF INCORPORATION

OF

HHC Assistance Corporation

Under Section 402 of the Not-for-Profit
Corporation Law

The undersigned, a natural person over the age of eighteen years, for the purpose of forming a corporation pursuant to the Not-for-Profit Corporation Law of the State of New York (hereinafter referred to as the "Not-for-Profit Corporation Law"), hereby certifies as follows:

FIRST: The name of the corporation is HHC Assistance Corporation (hereinafter referred to as the "Corporation").

SECOND: The Corporation described herein is a corporation as defined in Section 102(a)(5) of the Not-for-Profit Corporation Law. The Corporation shall not be conducted or operated for profit and no part of the net earnings of the Corporation shall inure to the benefit of any individual, nor shall any of the profits or assets of the Corporation be used other than for the purposes of the Corporation. Reasonable compensation, however, may be paid for services rendered to or for the Corporation in furtherance of one or more of its purposes.

THIRD:

I. The purposes for which the Corporation is formed are as follows:

(a) Assisting the New York City Health and Hospitals Corporation ("HHC") to secure sources of funding for its activities undertaken in furtherance of its statutory mission, including funding from New Market Tax Credits.

(b) Entering into funding agreements for the benefit of HHC, assisting with the administration of funding agreements entered into for HHC's benefit and performing tasks useful to HHC and in furtherance of HHC's corporate and statutory purposes.

(c) Maintaining a fund or funds of real and/or personal property and applying the whole or any part of the income and/or principal thereof exclusively for the benefit of the Corporation and appropriate in connection with the purposes of the Corporation and lawful for not-for-profit corporations.

(d) Exercising such other lawful powers which are necessary, convenient or desirable to carry out and promote its exempt purpose.

II. Tax Language: Notwithstanding any other provision of this Certificate of Incorporation, the Corporation is organized exclusively for charitable, scientific, religious, or educational purposes, as specified in Section 501(c)(3) of the Internal Revenue Code of 1986, as amended (the "Code"), and shall not carry on any activities not permitted to be carried on (a) by a corporation exempt from Federal income tax under Section 501(c)(3) of the Code or (b) by a corporation contributions to which are deductible under Section 170(c)(2) of the Code, Section 2055(a)(2) of the Code, or Section 2522(a)(2) of the Code.

III. Nothing herein shall authorize the Corporation, directly or indirectly, to engage in or include among its purposes, any of the activities mentioned in Section 404 of the Not-for-Profit Corporation Law.

IV. No substantial part of the activities of the Corporation shall be carrying on propaganda, or otherwise attempting to influence legislation (except as otherwise provided by Section 501(h) of the Code), and the Corporation shall not participate in, or

intervene in (including the publication or distribution of statements), any political campaign on behalf of any candidate for public office.

FOURTH: The Corporation shall be considered a Type C Corporation as that term is defined in Section 201 of the Not-for-Profit Corporation Law. The sole member of the Corporation shall be the New York City Health and Hospitals Corporation.

FIFTH: The lawful public objective of the Corporation is as follows: To improve the ability of HHC to provide services to its patients regardless of their ability to pay and thereby to further HHC's essential public and governmental purposes.

SIXTH: The office of the Corporation is to be located in the County of New York and State of New York.

SEVENTH: In the event of liquidation, dissolution, or winding up of the Corporation, whether voluntary, involuntary, or by the operation of law, the property or other assets of the Corporation remaining after the payment, satisfaction, and discharge of liabilities or obligations, shall be distributed entirely to the New York City Health and Hospitals Corporation, an exempt organization within the meaning of Section 501(c)(3) of the Code, subject to the order of the Supreme Court as and when provided by law. No individual shall have any right, title, or interest in or to any of the remaining assets of the Corporation.

EIGHTH: The names and addresses of the persons to be the Corporation's initial Board of Directors are as follows:

Alan D. Aviles	125 Worth Street, Rm. 514 New York, NY 10013
Antonio Martin	125 Worth Street, Rm. 514 New York, NY 10013

Salvatore J. Russo

125 Worth Street, Rm. 527
New York, NY 10013

Laray Brown

125 Worth Street, Rm. 507
New York, NY 10013

Marlene Zurack

160 Water Street, Rm. 1014
New York, NY 10038

NINTH: The duration of the Corporation shall be perpetual.

TENTH: The Secretary of the State, pursuant to Section 402(a)(6) of the Not-for-Profit Corporation Law, is hereby designated as the agent of the Corporation upon whom process against it may be served, and the post office address to which the Secretary of State shall mail a copy of any process against the Corporation served upon him or her is:

Senior Vice President for Legal Affairs
New York City Health and Hospitals Corporation
125 Worth Street -- Room 527
New York, NY 10013

IN WITNESS WHEREOF, I have made, signed and acknowledged this Certificate of Incorporation this 5th day of October, 2012.

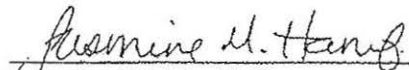

Jasmine M. Hanif, Esq.
Incorporator
Katten Muchin Rosenman LLP
575 Madison Avenue
New York, New York 10022-2585

121005001248

CSC 45
DRAW DOWN

CERTIFICATE OF INCORPORATION
OF
HHC Assistance Corporation
Under Section 402 of the Not-for-Profit
Corporation Law

RECEIVED

2012 OCT -5 PM 2:35

FILED

2012 OCT -5 PM 3:20

lrc
STATE OF NEW YORK
DEPARTMENT OF STATE

FILED OCT 05 2012

TAX S _____
BY: *lrc*

W

Katten Muchin Rosenman LLP
575 Madison Avenue
New York, New York 10022

CUSTOMER REF. # *362969 STR*

1311

INCUMBANCY CERTIFICATE

The undersigned, the duly elected Secretary of the HHC Assistance Corporation hereby certifies that the following individuals were duly elected to the offices indicated below at a meeting duly noticed of the Board of Directors of the HHC Assistance Corporation held on the ___ day of October, 2012 at which a quorum was present:

President:	Alan D. Aviles
Senior Assistant Vice President:	Antonia Martin
Senior Assistant Vice President:	Laray Brown
Senior Assistant Vice President and Treasurer:	Marlene Zurack
Senior Assistant Vice President and Secretary	Salvatore J. Russo

Dated: New York, New York
October __ 2012

Salvatore J. Russo, Senior Assistant
Vice President and Secretary

RESOLUTION

Authorizing the President of the New York City Health and Hospitals Corporation (the "Corporation" or "Licensee") to execute one year revocable license agreements with the New York City Human Resources Administration (the "Licensor" or "HRA") for use and occupancy of space for primary care programs located at 1420 Bushwick Avenue, Borough of Brooklyn, 413 E. 120th Street, Borough of Manhattan and 114-02 Guy Brewer Boulevard, Borough of Queens administered by Woodhull Medical and Mental Health Center, Metropolitan Hospital Center and Queens Hospital Center (the "Facilities").

WHEREAS, in October 2009, the Board of Directors of the Corporation authorized the President to execute a revocable license agreement with the New York City Human Resources Administration ("HRA"), which authorization allows use and occupancy of space at 114-02 Guy Brewer Boulevard for five (5) years; and

WHEREAS, in April 2010, the Board of Directors of the Corporation authorized the President to execute a revocable license agreement with the New York City Human Resources Administration ("HRA"), which authorization allows use and occupancy of space at 1420 Bushwick Avenue for three (3) years; and

WHEREAS, in June 2011, the Board of Directors of the Corporation authorized the President to execute a revocable license agreement with the New York City Human Resources Administration ("HRA"), which authorization allows use and occupancy of space at 413 E. 120th Street for three (3) years; and

WHEREAS, the Corporation occupies space in HRA operated City-owned buildings know as Multi-Service Services Centers ("MSCs"), and during the use and occupancy period authorized by the Board, the Corporation executes one year occupancy agreements with HRA, effective July 1st, at each of the MSC sites; and

WHEREAS, HRA has implemented a three dollar per square foot increase in the occupancy fee effective July 1, 2012 at each of the MSC sites occupied by the Corporation.

NOW, THEREFORE, be it

RESOLVED, that the President of the New York City Health and Hospitals Corporation be and hereby is authorized to execute a one year revocable license agreements with the New York City Human Resources Administration (the "Licensor" or "HRA") for use and occupancy of space for primary care programs located at 1420 Bushwick Avenue, Borough of Brooklyn, 413 E. 120th Street, Borough of Manhattan and 114-02 Guy Brewer Boulevard, Borough of Queens administered by Woodhull Medical and Mental Health Center, Metropolitan Hospital Center and Queens Hospital Center (the "Facilities").

**Page Two – Resolution
HRA Multi-Service Centers**

The Licensee shall be granted the continued use and occupancy of space in the three (3) HRA operated MSCs for programs managed by the Facilities. The occupancy fee for each site shall be increased by \$3 per square foot effective July 1, 2012. The total annual occupancy costs including the increase shall be approximately \$303,251 for the space at 114-02 Guy Brewer Boulevard, \$20,642 for the space at 1420 Bushwick Avenue and \$89,368 for the space at 413 E. 120th Street. There shall be no change in the utility surcharge or cooling season surcharge.

Site	Floor Area (sf)	Total Occupancy Costs	Increase @ \$3/sf	Total Occupancy Costs w/ increase
114-02 Guy Brewer Blvd.	11,471	\$268,838	\$34,413	\$303,251
1420 Bushwick Ave.	814	\$18,200	\$2,442	\$20,642
413 E. 120 th St.	2,738	\$81,154	\$8,214	\$89,368
Total	15,023	\$368,192	\$45,069	\$413,261

EXECUTIVE SUMMARY

QUEENS HOSPITAL CENTER WOOHULL MEDICAL AND MENTAL HEALTH CENTER METROPOLITAN HOSPITAL CENTER NYC HUMAN RESOURCES ADMINISTRATION MULTI-SERVICE CENTERS

OVERVIEW: The President seeks authorization to execute one year revocable license agreements with the New York City Human Resources Administration (the "Licensor" or "HRA") for use and occupancy of space for primary care programs located at 1420 Bushwick Avenue, Borough of Brooklyn, 413 E. 120th Street, Borough of Manhattan and 114-02 Guy Brewer Boulevard, Borough of Queens administered by Woodhull Medical and Mental Health Center, Metropolitan Hospital Center and Queens Hospital Center

**NEED/
PROGRAM:** In October 2009, the Board of Directors of the Corporation authorized the President to execute a revocable license agreement with the New York City Human Resources Administration ("HRA"), which authorization allows use and occupancy of space at 114-02 Guy Brewer Boulevard for five (5) years. In April 2010, the Board of Directors of the Corporation authorized the President to execute a revocable license agreement with the New York City Human Resources Administration ("HRA"), which authorization allows use and occupancy of space at 1420 Bushwick Avenue for three (3) years. In June 2011, the Board of Directors of the Corporation authorized the President to execute a revocable license agreement with the New York City Human Resources Administration ("HRA"), which authorization allows use and occupancy of space at 413 E. 120th Street for three (3) years.

HRA oversees Multi-Service Centers ("MSCs") located in City-owned buildings. The MSCs are managed by non-profit organizations and space is leased to non-profit community groups who provide services which include health care, education, housing assistance, vocational training and mental health services. The Corporation operates primary care programs at the MSCs located in Queens and Manhattan, and a WIC program at the site located in Brooklyn.

During the use and occupancy period authorized by the Board, the Corporation executes one year occupancy agreements with HRA, effective July 1st at each of the MSC sites. HRA has implemented a three dollar per square foot increase in the occupancy fee effective July 1, 2012 at each of the MSC sites occupied by the Corporation.

**Page Two – Executive Summary
HRA Multi-Service Centers**

TERMS: The Corporation shall be granted the continued use and occupancy of space in the three (3) HRA operated MSCs for programs managed by the Facilities. The occupancy fee for each site shall be increased by \$3 per square foot effective July 1, 2012. The total annual occupancy costs including the increase shall be approximately \$303,251 for the space at 114-02 Guy Brewer Boulevard, \$20,642 for the space at 1420 Bushwick Avenue and \$89,368 for the space at 413 E. 120th Street. There shall be no change in the utility surcharge or cooling season surcharge.

Site	Floor Area (sf)	Total Occupancy Costs	Increase @ \$3/sf	Total Occupancy Costs w/ increase
114-02 Guy Brewer Blvd.	11,471	\$268,838	\$34,413	\$303,251
1420 Bushwick Ave.	814	\$18,200	\$2,442	\$20,642
413 E. 120 th St.	2,738	\$81,154	\$8,214	\$89,368
Total	15,023	\$368,192	\$45,069	\$413,261

SUMMARY OF ECONOMIC TERMS

SITES: South Queens Community Health Center
114-02 Guy Brewer Blvd.
Jamaica, NY 11433-1234

Bushwick Community Health Center
1420 Bushwick Ave.
Brooklyn, NY 11207

La Clinica Del Barrio
413 E. 120th St.
NY, NY 10456

LANDLORD: City of New York, Human Resources Administration ("HRA")

TERM: One (1) year

Rent:

Site	Total Occupancy Costs	Increase @ \$3/sf	Total Occupancy Costs w/ increase
114-02 Guy Brewer Blvd.	\$268,838	\$34,413	\$303,251
1420 Bushwick Ave.	\$18,200	\$2,442	\$20,642
413 E. 120 th St.	\$81,154	\$8,214	\$89,368
Total	\$368,192	\$45,069	\$413,261

**UTILITIES/
MAINTENANCE:**

Licensors shall provide hot and cold water, utilities, housekeeping, rubbish removal, structural and non-structural repairs and security.